

SOLJET

Sign Maker by Roland DG Corporation

SC-500

USER'S MANUAL

Thank you very much for purchasing this machine.

- To ensure correct and safe usage with a full understanding of this product's performance, please be sure to read through this manual completely and store it in a safe location.
- Unauthorized copying or transferral, in whole or in part, of this manual is prohibited.
- The contents of this operation manual and the specifications of this product are subject to change without notice.
- The operation manual and the product have been prepared and tested as much as possible. If you find any misprint or error, please inform us.
- Roland DG Corp. assumes no responsibility for any direct or indirect loss or damage which may occur through use of this product, regardless of any failure to perform on the part of this product.
- Roland DG Corp. assumes no responsibility for any direct or indirect loss or damage which may occur with respect to any article made using this product.

For the USA

FEDERAL COMMUNICATIONS COMMISSION RADIO FREQUENCY INTERFERENCE STATEMENT

This equipment has been tested and found to comply with the limits for a Class A digital device, pursuant to Part 15 of the FCC Rules.

These limits are designed to provide reasonable protection against harmful interference when the equipment is operated in a commercial environment.

This equipment generates, uses, and can radiate radio frequency energy and, if not installed and used in accordance with the instruction manual, may cause harmful interference to radio communications.

Operation of this equipment in a residential area is likely to cause harmful interference in which case the user will be required to correct the interference at his own expense.

Unauthorized changes or modification to this system can void the users authority to operate this equipment.

The I/O cables between this equipment and the computing device must be shielded.

NOTICE

Grounding Instructions

Do not modify the plug provided - if it will not fit the outlet, have the proper outlet installed by a qualified electrician.

Check with qualified electrician or service personnel if the grounding instructions are not completely understood, or if in doubt as to whether the tool is properly grounded.

Use only 3-wire extension cords that have 3-prong grounding plugs and 3-pole receptacles that accept the tool's plug.

Repair or replace damaged or worn out cord immediately.

Operating Instructions

KEEP WORK AREA CLEAN. Cluttered areas and benches invites accidents.

DON'T USE IN DANGEROUS ENVIRONMENT. Don't use power tools in damp or wet locations, or expose them to rain. Keep work area well lighted.

DISCONNECT TOOLS before servicing; when changing accessories, such as blades, bits, cutters, and like.

REDUCE THE RISK OF UNINTENTIONAL STARTING. Make sure the switch is in off position before plugging in.

USE RECOMMENDED ACCESSORIES. Consult the owner's manual for recommended accessories. The use of improper accessories may cause risk of injury to persons.

NEVER LEAVE TOOL RUNNING UNATTENDED.
TURN POWER OFF. Don't leave tool until it comes to a complete stop.

For Canada

CLASS A NOTICE

This Class A digital apparatus meets all requirements of the Canadian Interference-Causing Equipment Regulations.

CLASSE A AVIS

Cet appareil numérique de la classe A respecte toutes les exigences du Règlement sur le matériel brouilleur du Canada.



ROLAND DG CORPORATION

1-6-4 Shinmiyakoda, Hamamatsu-shi, Shizuoka-ken, JAPAN 431-2103

MODEL NAME : See the MODEL given on the rating plate.

RELEVANT DIRECTIVE : EC MACHINERY DIRECTIVE (98/37/EC)

EC LOW VOLTAGE DIRECTIVE (73/23/EEC)

EC ELECTROMAGNETIC COMPATIBILITY DIRECTIVE (89/336/EEC)

WARNING

This is a Class A product. In a domestic environment this product may cause radio interference in which case the user may be required to take adequate measures.

Contents

To Ensure Safe Use	2	Maintenance	44
About the Labels Affixed to the Unit	5	Replacing the Ink Cartridges	44
Pour utiliser en toute sécurité	7	Check how much ink remains	46
À propos des étiquettes collées sur l'appareil ..	10	Cleaning the Printing Heads	46
What to Do upon Opening the Carton	13	Replacing the Cutter Blade	48
1 Checking Accessories	13	How to Replace the Separating Knife	49
2 Setting Up and Connection	14	When the Product Needs Cleaning	50
3 Attach the Drain Bottle	16	When Not in Use for a Prolonged Period... ..	51
4 Installing Ink Cartridges	18	When Moving the Unit... ..	52
Part Names	21	User's Reference	55
Front View	21	Environment Matching	55
Rear View	22	Performing Cutting or Printing at the Desired	
Inside the Front Cover	22	Location	56
Operation Panel	23	Adjusting the Printing and Cutting Positions	57
Five Modes	24	Remove the Printed Material, then Reload the	
Setup for Printing	25	Material and Perform Cutting	59
1 Loading the Material	25	Making Corrections for Printing	64
2 Test Printing	29	Aligning the Printing Length and Cutting Length	66
3 Setting the Printing Mode and Printing Direction	30	Performing Overprinting	67
Setup for Cutting	31	Setting the Page Margins	68
1 Loading the Material	31	About the Prefeed ([PREFEED]) Function	69
2 Installing a Blade	35	To Perform Long Printing/Cutting	70
3 Test Cutting.....	36	Adjusting the Height of the Printing Head	71
Setup for Printing and Cutting	38	Materials	72
Downloading Printing/Cutting Data	39	About Blade Life	74
Remove the Material	41	About the Printing/Cutting Area	75
Remove the Material from the machine	41	Description of Keys	77
Cut the material from the roll	41	Description of Menu Items	79
When Operations Are Finished	43	Description of Menus	79
		Display Menus Flowchart	83
		What to Do If...	87
		Error Messages	92
		Specifications	94

SOLJET™ and SOL INK™ are trademarks of Roland DG Corporation.

COLORCHOICE® is a registered in the U.S. Patent Office.

Windows® is a registered trademark or trademark of Microsoft® Corporation in the United States and/or other countries.



IBM is a registered trademark of International Business Machines Corporation.

Macintosh is a registered trademark or trademark of Apple Computer, Inc. in the USA and other countries.



Other company names and product names are trademarks or registered trademarks of their respective holders.

To Ensure Safe Use

About ⚠️ WARNING and ⚠️ CAUTION Notices

 WARNING	Used for instructions intended to alert the user to the risk of death or severe injury should the unit be used improperly.
 CAUTION	Used for instructions intended to alert the user to the risk of injury or material damage should the unit be used improperly. * Material damage refers to damage or other adverse effects caused with respect to the home and all its furnishings, as well to domestic animals or pets.

About the Symbols

	The ⚠️ symbol alerts the user to important instructions or warnings. The specific meaning of the symbol is determined by the design contained within the triangle. The symbol at left means "danger of electrocution."
	The ⚡ symbol alerts the user to items that must never be carried out (are forbidden). The specific thing that must not be done is indicated by the design contained within the circle. The symbol at left means the unit must never be disassembled.
	The ● symbol alerts the user to things that must be carried out. The specific thing that must be done is indicated by the design contained within the circle. The symbol at left means the power-cord plug must be unplugged from the outlet.

⚠️ WARNING



Do not disassemble, repair, or modify.

Doing so may lead to fire or abnormal operation resulting in injury.



Use only with a power supply of the same rating as indicated on the unit.

Use with any other power supply may lead to fire or electrocution.



Ground the unit with the ground wire.

Failure to do so may result in risk of electrical shock in the even of a mechanical problem.



Do not use while in an abnormal state (i.e., emitting smoke, burning odor, unusual noise, or the like).

Doing so may result in fire or electrical shock.



Use only with the power cord included with this product.

Use with other than the included power cord may lead to fire or electrocution.

Immediately switch off first the sub power, then the main power, unplug the power cord from the electrical outlet, and contact your authorized Roland DG Corp. dealer or service center.

WARNING



Do not operate in a location exposed to open flame, sparking, or static electricity, or in a location exposed to high temperatures, such as in the immediate vicinity of a heater. Also, do not place undried media in such locations.

Doing so may result in fire due to combustion of ink or cleaning liquid.



Do not store ink cartridges, cleaning liquid, or discharged ink in locations such as the following.

- Near open flame
- Locations exposed to high temperatures, such as in the immediate vicinity of a heater
- Near bleach, chemicals, explosives, or the like

Doing so may cause fire.

CAUTION



Ensure adequate ventilation for the work area.

Failure to do so may result in odor, physical distress, or fire.



Do not allow ink or cleaning liquid to come into contact with eyes or skin. Do not drink or deliberately smell ink or cleaning liquid.

Doing so may be hazardous to your health.



If ink or cleaning liquid comes in contact with the eyes, immediately flush with running water for at least 15 minutes. If eye irritation continues, seek treatment by a physician.



If ink or cleaning liquid comes in contact with the skin, immediately wash well with soap and water. If irritation or inflammation occur, seek treatment by a physician.



If ink or cleaning liquid is accidentally swallowed, do not induce vomiting, and immediately seek treatment by a physician.



If the odor of the ink or cleaning liquid causes physical distress, move to a well-ventilated location and rest quietly. If dizziness or nausea persists, seek treatment by a physician.



When storing discharged ink temporarily, place in the included drain bottle or a durable sealed container such as a metal can and polyethylene tank, and cap tightly. Leakage of discharged ink or its vapor may result in odor, physical distress, or fire.



Store ink cartridges out of the reach of children.

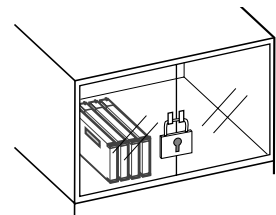

⚠ CAUTION



Do not use with a damaged power cord or plug, or with a loose electrical outlet.

Use with any other power supply may lead to fire or electrocution.

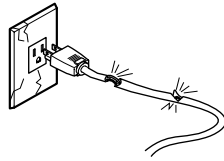

Do not attempt to unplug the power cord with wet hands.

Doing so may result in electrical shock.

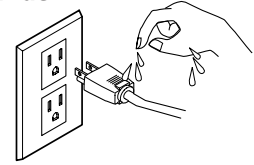

Do not injure or modify the electrical power cord, nor subject it to excessive bends, twists, pulls, binding, or pinching, nor place any object of weight on it.

Doing so may damage the electrical power cord, leading to electrocution or fire.

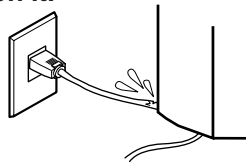

When unplugging the electrical power cord from the power outlet, grasp the plug, not the cord.

Unplugging by pulling the cord may damage it, leading to fire or electrocution.

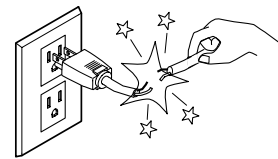

Do not allow liquids, metal objects or flammables inside the machine.

Such materials can cause fire.

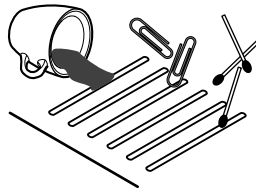

Unpacking, installation, and moving must be carried out by two or more persons.

Failure to do so may result in falling of the unit, leading to injury.

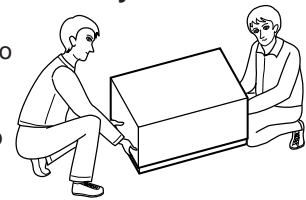

Install in a level and stable location.

Otherwise the unit may tip over and cause injury.

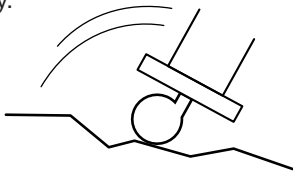

Use the joining screws to secure the unit to the stand.

Failure to do so may result in falling of the unit, leading to injury.

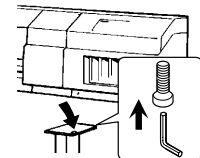

Use care to avoid pinching the fingers when placing the unit on the stand.

Doing so may result in injury.

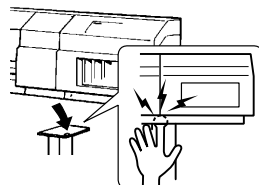

Release the caster locks for the stand before attempting to move.

Otherwise the unit may tip over and cause injury.

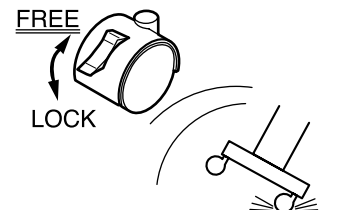

CAUTION



Roll material must be placed at a predetermined shaft position.

Failure to do so may result in falling of the roll, leading to injury.

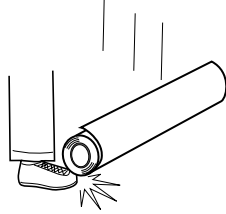

Do not place hands within the space to the front of the unit while in operation.

Doing so may result in injury.

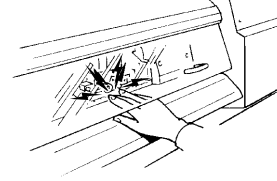

Do not touch the tip of the blade with your fingers.

Doing so may result in injury.



Make sure the power to the unit is off before attempting to replace the separating knife.

Doing so may result in injury.

About the Labels Affixed to the Unit

These labels are affixed to the body of this product.

The following figure describes the location and content of these messages.

Ink cartridge

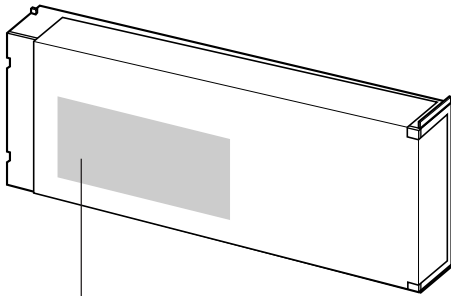

**Ink and discharged ink are flammable.
Keep away from open flame.**



**Ink and discharged ink are toxic. Avoid
contact with the body. Use only in a
well-ventilated area.**

Do not dismantle the cartridge.

Keep out of reach of children.

Do not store the cartridge in high or freezing temperatures.

Use only models that support SOL INK. Do not insert this cartridge into a model that does not support SOL INK.



Ink and discharged ink are flammable. Keep away from open flame.



Ink and discharged ink are toxic. Avoid contact with the body. Use only in a well-ventilated area.

Use only SOL INK. Do not insert any other type of ink cartridge.
SOL INK専用です。他のインクカートリッジを挿入しないでください。

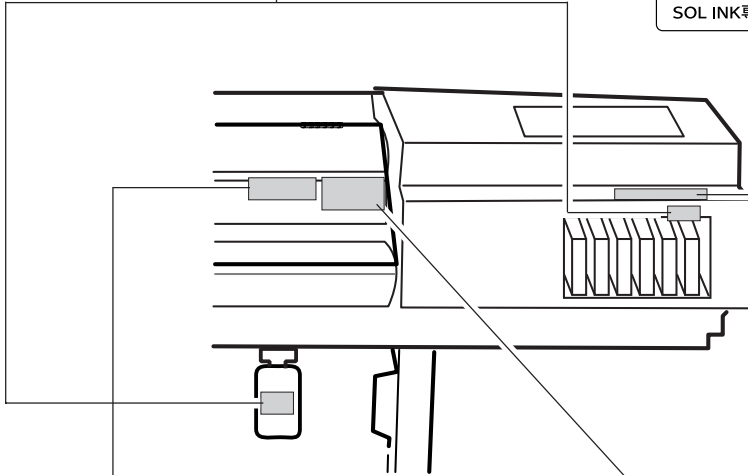

Opening the front cover while printing is in progress causes an emergency stop.
To pause printing for any other reason than an emergency stop, press the [PAUSE] key.
印刷中にフロントカバーを開けると緊急停止します。
緊急停止以外の一時停止は、[PAUSE]キーを押してください。



Do not place hands within the space to the front of the unit while in operation.

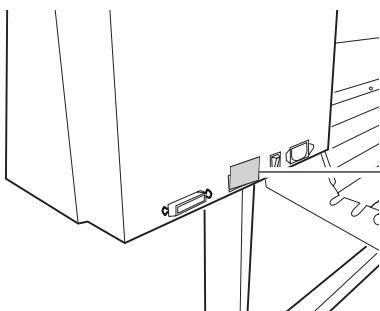

**Model name
Rating label**
Use a rated power supply.

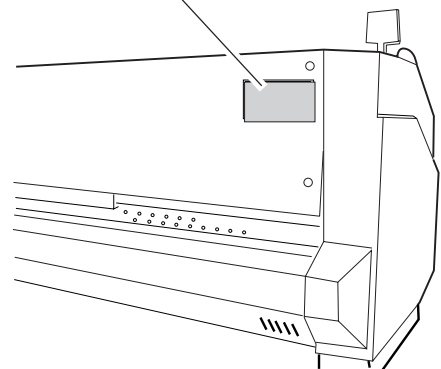

In addition to the **⚠ WARNING** and **⚠ CAUTION** symbols, the symbols shown below are also used.



NOTICE : Indicates information to prevent machine breakdown or malfunction and ensure correct use.









: Indicates a handy tip or advice regarding use.

Pour utiliser en toute sécurité

Avis sur les avertissements

 ATTENTION	Utilisé pour avertir l'utilisateur d'un risque de décès ou de blessure grave en cas de mauvaise utilisation de l'appareil.
 PRUDENCE	Utilisé pour avertir l'utilisateur d'un risque de blessure ou de dommage matériel en cas de mauvaise utilisation de l'appareil. * Par dommage matériel, il est entendu dommage ou tout autre effet indésirable sur la maison, tous les meubles et même les animaux domestiques.

À propos des symboles

	Le symbole  attire l'attention de l'utilisateur sur les instructions importantes ou les avertissements. Le sens précis du symbole est déterminé par le dessin à l'intérieur du triangle. Le symbole à gauche signifie "danger d'électrocution".
	Le symbole  avertit l'utilisateur de ce qu'il ne doit pas faire, ce qui est interdit. La chose spécifique à ne pas faire est indiquée par le dessin à l'intérieur du cercle. Le symbole à gauche signifie que l'appareil ne doit jamais être démonté.
	Le symbole  prévient l'utilisateur sur ce qu'il doit faire. La chose spécifique à faire est indiquée par le dessin à l'intérieur du cercle. Le symbole à gauche signifie que le fil électrique doit être débranché de la prise.

ATTENTION



Ne pas démonter, réparer ou modifier.

Le non-respect de cette consigne pourrait causer un incendie ou provoquer des opérations anormales entraînant des blessures.



Utiliser seulement avec une alimentation de mêmes caractéristiques électriques que celles indiquées sur l'appareil.

Une négligence à ce niveau pourrait provoquer un incendie ou une électrocution.



Mettre l'appareil à la masse avec une prise de terre.

Le non-respect de cette consigne pourrait entraîner des décharges électriques en cas de problème mécanique.



Ne pas utiliser si l'appareil est dans un état anormal (c'est-à-dire s'il y a émission de fumée, odeur de brûlé, bruit inhabituel etc.).

Le non-respect de cette consigne pourrait provoquer un incendie ou des décharges électriques.



N'utilisez que le cordon d'alimentation fourni avec ce produit.

L'utilisation avec un autre cordon d'alimentation que celui fourni pourrait entraîner un risque d'incendie ou d'électrocution.

Couper immédiatement l'alimentation secondaire et ensuite l'alimentation principale. Débranchez le fil électrique et contacter votre revendeur ou votre centre de service de la société Roland DG autorisé.

ATTENTION



Ne pas utiliser près d'une flamme nue, dans un endroit où se produisent des étincelles ou de l'électricité statique, ni dans un endroit où les températures sont élevées, par exemple à proximité d'un appareil de chauffage.

De plus, il ne faut pas placer le support humide dans de tels endroits car la combustion de l'encre ou du liquide nettoyant peut créer un risque d'incendie.



Ne pas entreposer les cartouches d'encre, le liquide nettoyant ou l'encre usée dans les endroits suivants :

- près d'une flamme nue,
- dans des endroits où les températures sont élevées, par exemple à proximité d'un appareil de chauffage,
- près de javellisants, de produits chimiques, d'explosifs ou autres produits semblables.

Cela crée un risque d'incendie.

PRUDENCE



S'assurer que le lieu de travail est bien aéré.

Sinon, des odeurs fortes peuvent se dégager et il y a risque de malaises physiques ou d'incendie.



Ne pas mettre le liquide nettoyant en contact avec les yeux ou la peau. Ne pas boire ou ni respirer délibérément l'encre ou le liquide nettoyant.

Cela est dangereux pour la santé.



Si de l'encre ou le liquide nettoyant viennent en contact avec les yeux, rincer immédiatement à l'eau courante pendant au moins 15 minutes. Si les yeux sont toujours irrités, consulter un médecin.



Si de l'encre ou du liquide nettoyant entrent en contact avec la peau, immédiatement laver à fond avec de l'eau et du savon. Si la peau devient irritée ou inflammée, consulter un médecin.



Si de l'encre ou du liquide nettoyant sont avalés accidentellement, ne pas provoquer le vomissement, et consulter un médecin immédiatement.



Si l'odeur de l'encre ou du liquide nettoyant cause un malaise physique, amener immédiatement la personne dans un endroit bien aéré et la laisser se reposer. Si l'étourdissement ou les nausées persistent, consulter un médecin.



Pour entreposer temporairement l'encre usée, la placer dans un solide contenant scellé, par exemple un contenant en métal et un réservoir en polyéthylène, et fermer hermétiquement.

Les fuites d'encre usée ou la vapeur qui s'en échappe peuvent causer des odeurs fortes, des malaises physique ou un incendie.



Ranger les cartouches d'encre hors de portée des enfants.

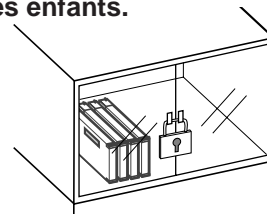

PRUDENCE



Ne pas utiliser avec une fiche ou un fil électrique endommagé ou avec une prise mal fixée.

Une négligence à ce niveau pourrait provoquer un incendie ou une électrocution.

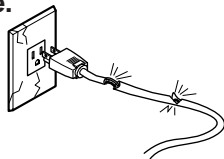

Ne pas essayer de débrancher le fil avec des mains mouillées.

Une négligence à ce niveau pourrait provoquer des décharges électriques.

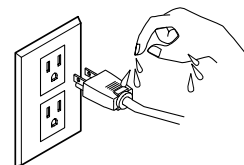

Ne pas endommager ou modifier le fil électrique. Ne pas le plier, le tordre, l'étirer, l'attacher ou le serrer de façon excessive. Ne pas mettre d'objet ou de poids dessus.

Une négligence à ce niveau pourrait endommager le fil électrique ce qui risquerait de provoquer une électrocution ou un incendie.

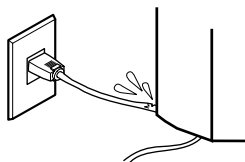

Saisir la fiche et non le fil électrique lorsque vous débranchez.

Débrancher en tirant sur le fil pourrait l'endommager et risquer de provoquer un incendie ou une électrocution.

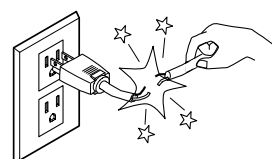

Ne pas introduire de liquide, d'objet métallique ou inflammable dans l'appareil.

Ce genre de matériel peut provoquer un incendie.

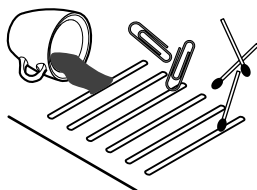

Le déballage, l'installation et le déplacement de l'appareil doivent être effectués par deux personnes ou plus.

Le non-respect de cette consigne pourrait causer des défauts dans l'appareil entraînant des blessures.



Installer dans un endroit stable et de niveau.

Sinon l'appareil pourrait se renverser et provoquer des blessures.

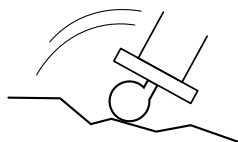

Utiliser les vis fournies pour bien fixer l'appareil sur le support.

Le non-respect de cette consigne pourrait causer des défauts dans l'appareil entraînant des blessures.

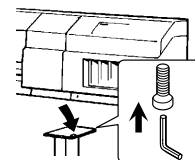

Manipuler avec précaution pour éviter de se coincer les doigts lors de l'installation de l'appareil sur le support.

Une négligence à ce niveau pourrait provoquer des blessures.

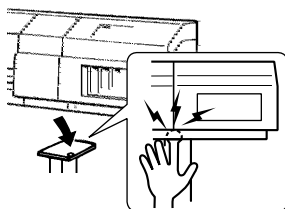

Débloquer le mécanisme d'arrêt des roulettes du support avant de le déplacer.

Sinon l'appareil pourrait se renverser et provoquer des blessures.

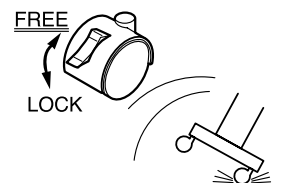

PRUDENCE



Le rouleau doit être placé quand la barre est en position adéquate.

Une négligence à ce niveau pourrait provoquer la chute du rouleau et causer des blessures.

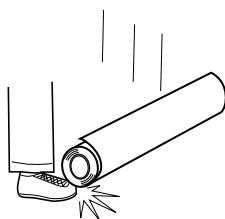

Ne pas mettre les mains dans l'espace du devant quand l'appareil est en marche.

Une négligence à ce niveau pourrait provoquer des blessures.

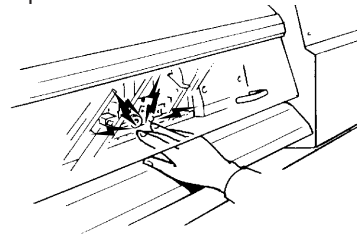

Ne pas toucher à l'extrémité de la lame avec vos doigts.

Une négligence à ce niveau pourrait provoquer des blessures.

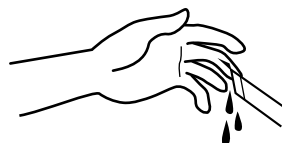

S'assurer que l'appareil est hors tension avant d'essayer de remplacer la lame séparatrice.

Une négligence à ce niveau pourrait provoquer des blessures.

À propos des étiquettes collées sur l'appareil

Ces étiquettes sont collées à l'extérieur de l'appareil.
Les dessins suivants indiquent l'endroit et le contenu des messages.

la cartouche d'encre

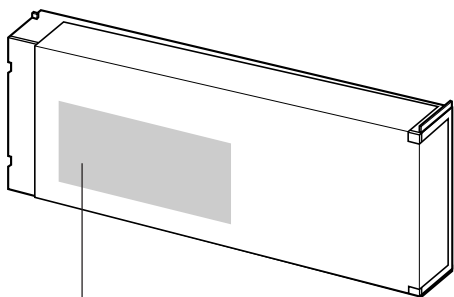

**L'encre et l'encre usée sont inflammables.
Les garder loin de toute flamme nue.**



L'encre et l'encre usée sont toxiques. Éviter tout contact avec le corps. Utiliser uniquement dans un endroit bien aéré.

**Ne pas démonter la cartouche.
Conserver hors de la portée des enfants.
Ne pas emmagasiner à des températures hautes ou basses.**

À n'utiliser que sur les modèles acceptant SOL INK. Ne pas insérer cette cartouche dans les modèles n'acceptant pas SOL INK.



L'encre et l'encre usée sont inflammables. Les garder loin de toute flamme nue.



L'encre et l'encre usée sont toxiques. Éviter tout contact avec le corps. Utiliser uniquement dans un endroit bien aéré.

Use only SOL INK. Do not insert any other type of ink cartridge. SOL INK専用です。他のインクカートリッジを挿入しないでください。

Utiliser uniquement l'encre SOL INK. Ne pas utiliser d'autres types de cartouches d'encre.

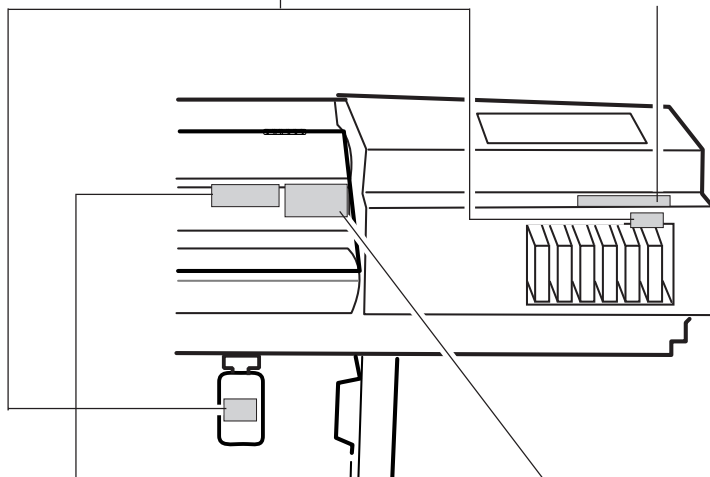

Opening the front cover while printing is in progress causes an emergency stop.
To pause printing for any other reason than an emergency stop, press the [PAUSE] key.
印刷中にフロントカバーを開けると緊急停止します。
緊急停止以外の一時停止は、[PAUSE]キーを押してください。

Ouvrir la plaque avant pendant l'impression provoque un arrêt d'urgence.
Appuyer sur [PAUSE] si, pour toute autre raison qu'une urgence, vous désirez suspendre momentanément l'impression.



Ne pas mettre les mains dans l'espace devant l'élément quand celui-ci est en marche.

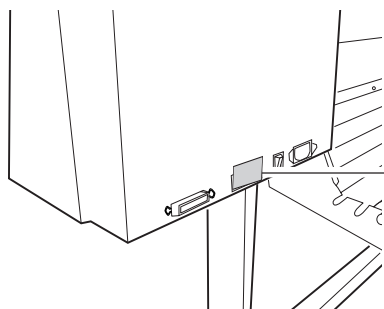

Nom du modèle
Étiquette des caractéristiques électriques

Utiliser l'alimentation appropriée

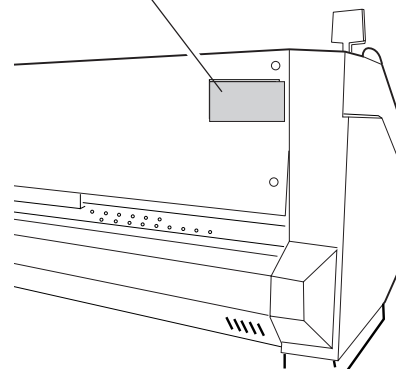

MEMO

What to Do upon Opening the Carton

1 Checking Accessories

Check the following to make sure that you received all the items that were shipped along with the unit.



Power cord: 1

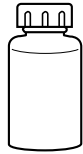

Drain bottle: 2



Drain-bottle cap: 1



Screws: 2



Blade: 1



Blade holder : 1

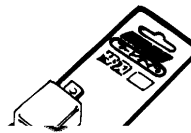

Replacement blade for separating knife: 1

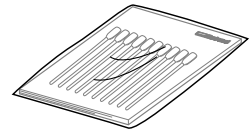

Cleaning kit: 1



Roland COLORCHOICE® : 1

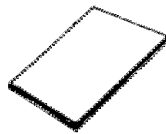

User's manual: 1

2 Setting Up and Connection

Setting Up

CAUTION



Unpacking, installation, and moving must be carried out by two or more persons.

Failure to do so may result in falling of the unit, leading to injury.

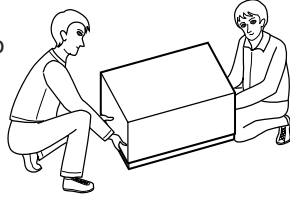

Install in a level and stable location.

Otherwise the unit may tip over and cause injury.

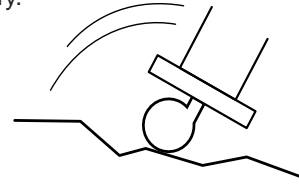

NOTICE

Be sure to install the drain bottle before switching on the power.

Use in the following environment.

- Temperature: 15 to 35 °C (59 to 95 °F), humidity: 35 to 80 % (no condensation)

Also, take care to ensure that the following conditions are not exceeded even when the machine is not in operation. In particular, be careful to make sure not to expose the machine to high temperatures of 40 °C (104 °F) or more.

- Temperature: 5 to 40 °C (41 to 104 °F), humidity: 20 to 80 % (no condensation)

Never install the unit in any of the following situations, as it could result in breakdown or faulty operation:

- Places where the installation surface is unstable or not level.
- Places with excessive electrical noise.
- Places with excessive humidity or dust.
- Places with poor ventilation, because the unit generates considerable heat during operation.
- Places with excessive vibration.
- Places exposed to strong illumination or direct sunlight.

Never step or stand on the stand legs, as doing so may damage them.

Do not place objects on the unit, as doing so may result in breakdown.

For an explanation of how to assemble the unit and the stand, refer to the “ASSEMBLY INSTRUCTIONS” included with the stand. When using the unit while mounted on a stand, be sure to ensure a sufficient amount of installation space for the unit. The required installation spaces for this model are listed below.

2700 mm (106-5/16 in.) wide, 900 mm (35-7/16 in.) depth, and 1500 mm (59-1/16 in.) high

Connection

⚠ WARNING



Use only with a power supply of the same rating as indicated on the unit.
Use with any other power supply may lead to fire or electrocution.



Ground the unit with the ground wire.

Failure to do so may result in risk of electrical shock in the even of a mechanical problem



Use only with the power cord included with this product.

Use with other than the included power cord may lead to fire or electrocution.

NOTICE

Before connecting the cable, make sure the computer's power and the main power switch of the unit are switched off.

Securely connect the power cord, computer I/O cable and so on so that they will not be unplugged and cause failure during operation. Doing so may lead to faulty operation or breakdown.

Arrange the power cord and interface connection cable to prevent tripping when moving around the unit.

Rear View

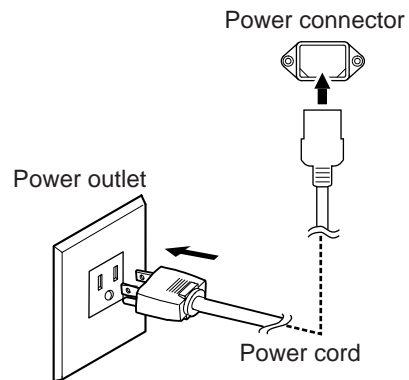
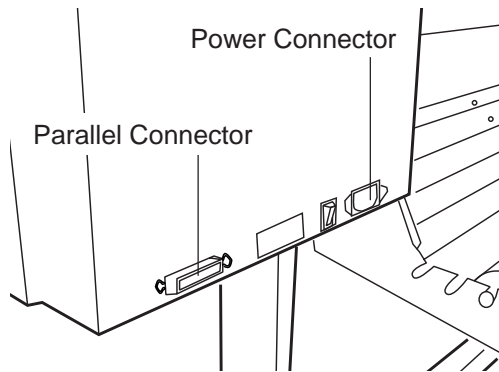

For IBM PC or PC compatibles

Parallel connector
Secure the cable in place with the clips.

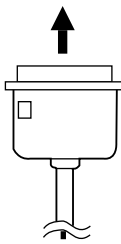

Parallel interface cable (Printer cable)

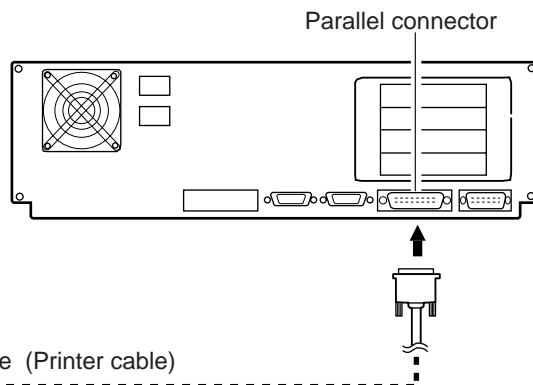

* Cables are available separately. One which you are sure matches the model of computer being used should be selected.

For Macintosh

Connection to a Macintosh requires optional items such as special cable. For more information on the required optional items and connection settings, contact a Roland dealer.

3 Attach the Drain Bottle

*The tube cap and the cap for the drain bottle are required when moving the machine, so do not discard them.

- 1 Detach the tube plug from the tube tips protruding from the bottom surface of the right-hand side of the unit.

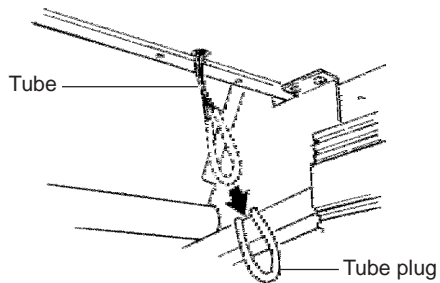

- 2 Pass the tube through the hole in the drain-bottle mounting cap and align with the threaded hole. Tighten the included screws.

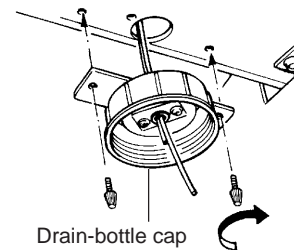

- 3 Remove the cap for the drain bottle and attach the drain bottle to the unit by screwing it on in the direction of the arrow. Line up the threads on the drain bottle with the threads on the unit, and screw on the bottle without applying excessive force. Leave this mounted unless transporting the main unit, or when it is full.

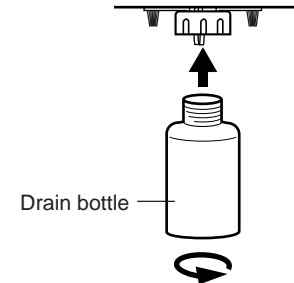

The machine comes with a spare drain bottle. Use it for storing discharged ink temporarily.

Disposal of Discharged Ink

When the ink is about to exceed the “Upper Limit” line on the drain bottle, or when moving the machine, follow the steps below to discard the ink.



When storing discharged ink temporarily, place in the included drain bottle or a durable sealed container such as a metal can and polyethylene tank, and cap tightly. Leakage of discharged ink or its vapor may result in odor, physical distress, or fire.

- 1** Press the [POWER] key to switch off the power.

The POWER LED goes out

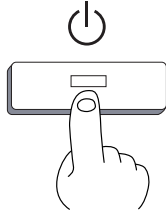

- 2** Remove the drain bottle and attach the tube plug to the tube tips instead.

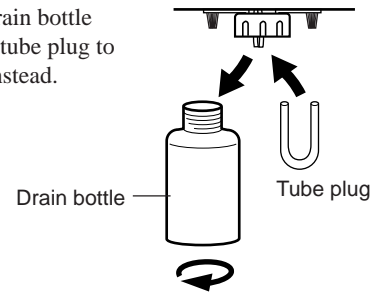

- 3** Dispose of discharged ink properly, in accordance with regional laws and regulations.

NOTICE Discharged ink is flammable and contains toxic ingredients. Do not attempt to incinerate discharged ink or discard it with ordinary trash. Also, do not dispose of it in sewer systems, rivers, or streams. Doing so may have an adverse impact on the environment.

4 Installing Ink Cartridges

WARNING



Do not operate in a location exposed to open flame, sparking, or static electricity, or in a location exposed to high temperatures, such as in the immediate vicinity of a heater. Also, do not place undried media in such locations.

Doing so may result in fire due to combustion of ink or cleaning liquid.



Do not store ink cartridges, cleaning liquid, or discharged ink in locations such as the following.

- Near open flame
- Locations exposed to high temperatures, such as in the immediate vicinity of a heater
- Near bleach, chemicals, explosives, or the like

Doing so may cause fire.

CAUTION



Ensure adequate ventilation for the work area.

Failure to do so may result in odor, physical distress, or fire.



Do not allow ink or cleaning liquid to come into contact with eyes or skin. Do not drink or deliberately smell ink or cleaning liquid.

Doing so may be hazardous to your health.



Store ink cartridges out of the reach of children.

NOTICE

Do not use anything other SOL INK cartridges. Do not attempt to refill and reuse an empty ink cartridge.

Do not remove any ink cartridges except when shipping the machine.

If ink runs out, replace immediately with the same type and the same color ink cartridge (see "Maintenance - Replacing the Ink Cartridges"). If an ink cartridge is removed, replace it immediately with a new one.

Do not attempt to disassemble an ink cartridge.

Store ink cartridges unopened at a temperature of -20 to 40 °C (-4 to 104 °F) in a well-ventilated location.

If an ink cartridge is dropped, the shock due to the fall may damage the ink cartridge and make it unusable.



Once an ink cartridge has been installed, do not remove it until the ink has been used up. Frequent insertion and removal may allow air to enter the ink tube and result in a drop in printing quality due to dot drop-out or the like.

Installing ink cartridges for the first time after purchase requires three SOL INK cleaning cartridges. This is also the case when you are draining ink in preparation for transport, then reinstalling the ink cartridges.

NOTICE Use only SOL INK. Do not insert any other type of ink cartridge.

- 1** Turn on the main power switch at the back of the unit.

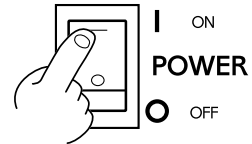

- 2** Press the [POWER] key on the operation panel.

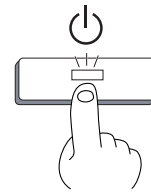

- 3** The display appears. Make sure an empty drain bottle is installed, then press the [ENTER] key on the operation panel.

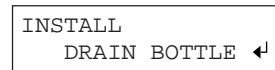

- 4** Insert cleaning cartridges into the ink-cartridge ports shown by flashing on the display. Insert the three cartridges firmly, as far as they will go. Washing starts. While the operation is in progress, remove the cartridges and insert them again. Follow the messages on the display to carry out the procedure.

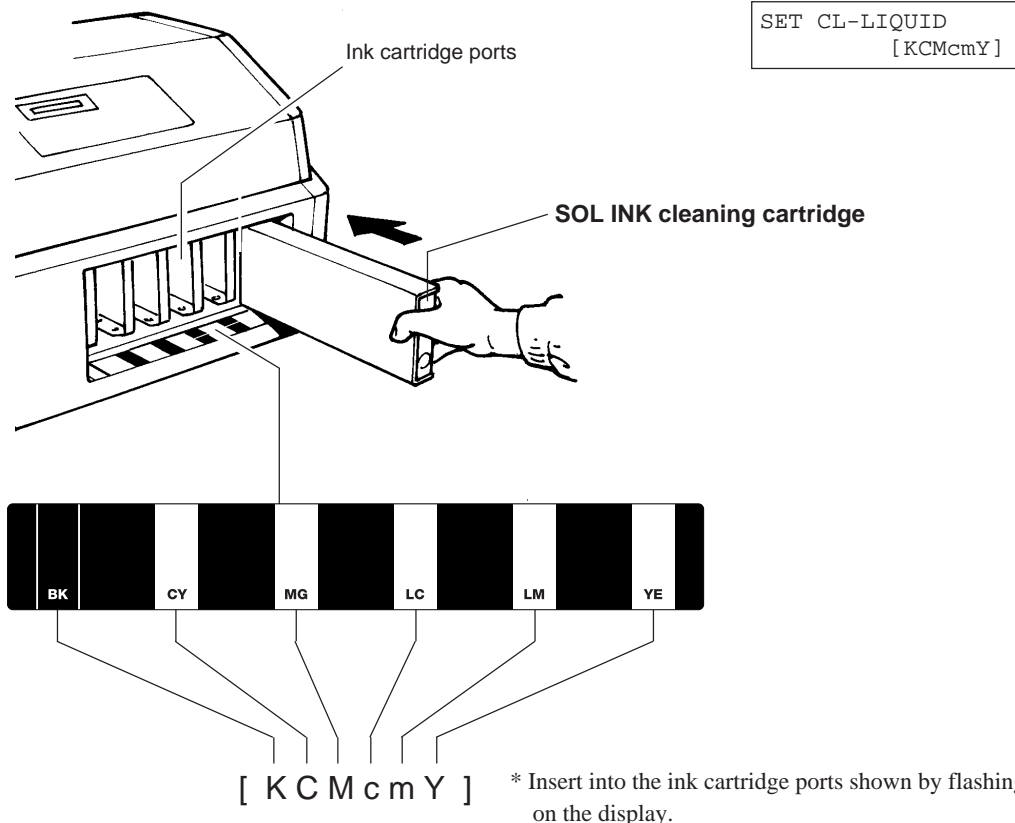

(Continued on the next page.)

What to Do upon Opening the Carton

- 5** When washing ends, the following message appears on the display. Firmly insert the SOL INK cartridges for each of the colors as far as they will go.

```
SET CARTRIDGE  
[KCMcmY]
```

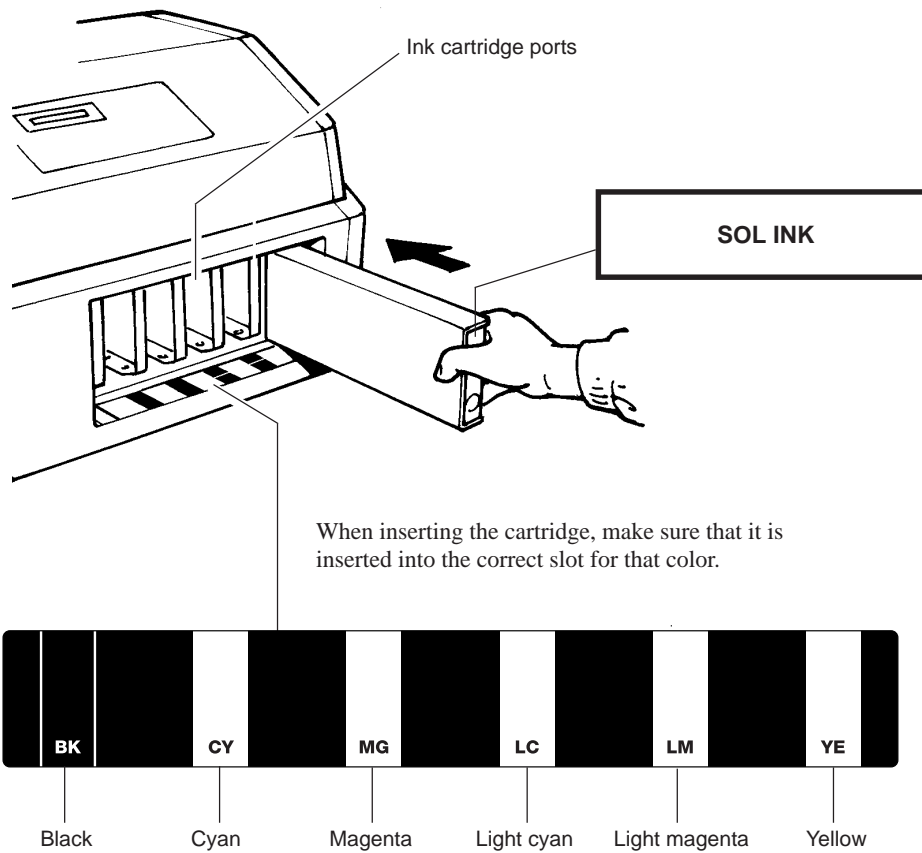

- 6** Make sure the following message is displayed, then press the [ENTER] key. Ink filling starts.

```
SELECT INK TYPE  
SOL CMYKLCm ←
```

- 7** Replace the drain bottle with an empty one, then press the [ENTER] key. This completes the installation of the ink cartridges.

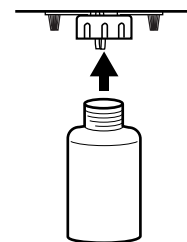

Part Names

Front View

NOTICE

If you will leave the printing head being uncapped for a long time (for example, open the front cover while printing is made on the middle of platen), printing heads may get clogging and, in some case it results unrecoverable damage to the printing head.

When the printing carriage is stopped on the platen, press the [POWER] key to reset the power. The carriage moves and the printing head is capped.

Do not touch the rail or place the hands inside the right-hand cover except when adjusting the height of the printing head. Touching the area shown may cause the fingers to be soiled by grease or ink, and may result in diminished image quality.

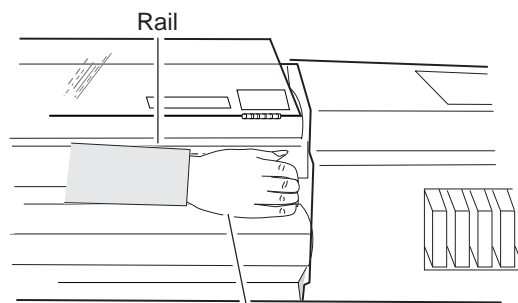

Do not put hands inside

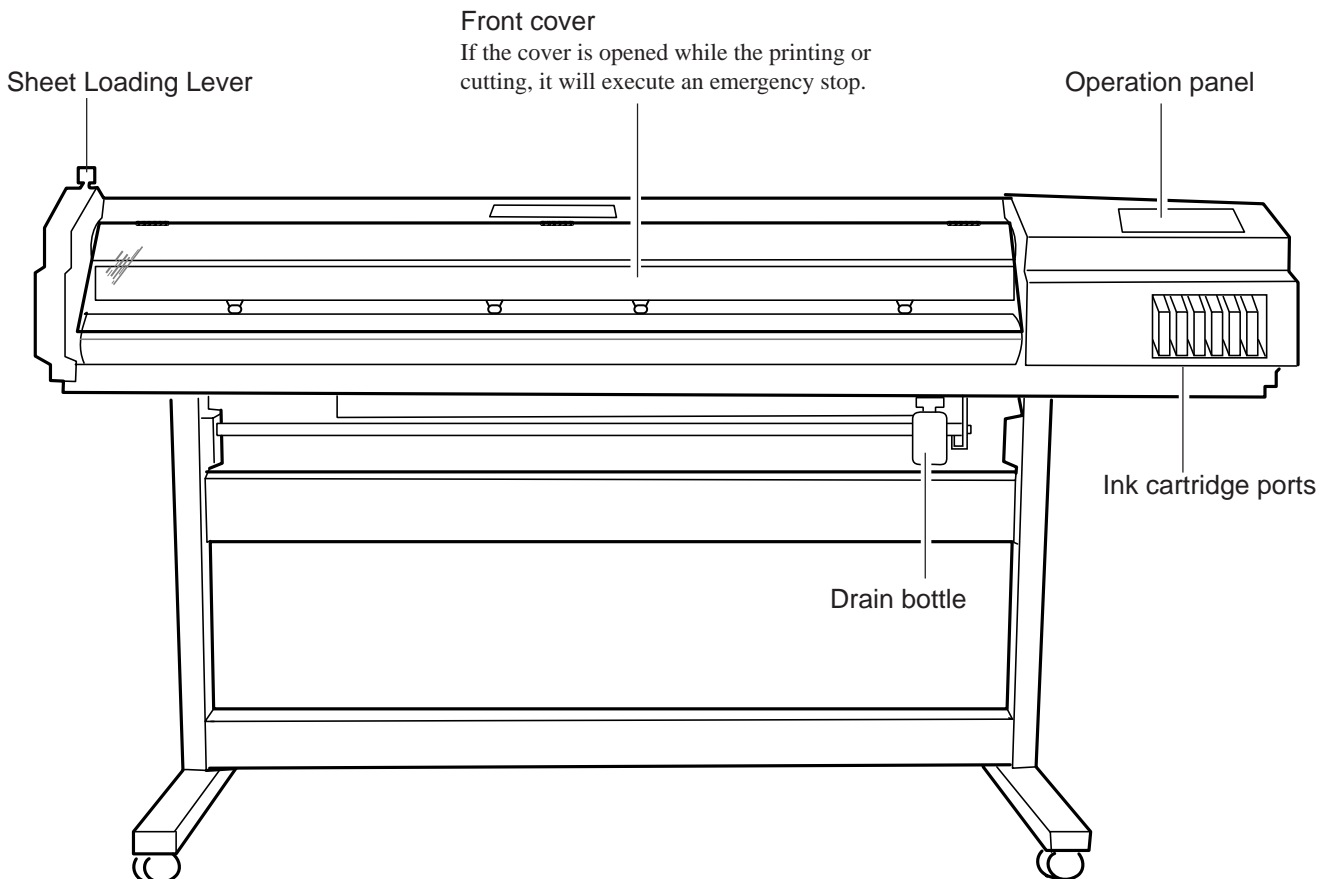

Rear View

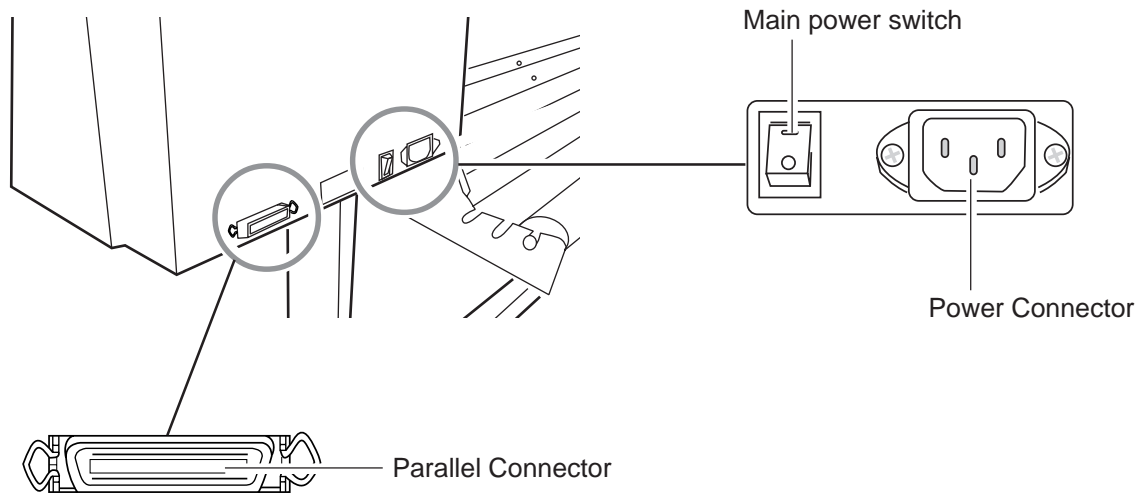

Inside the Front Cover

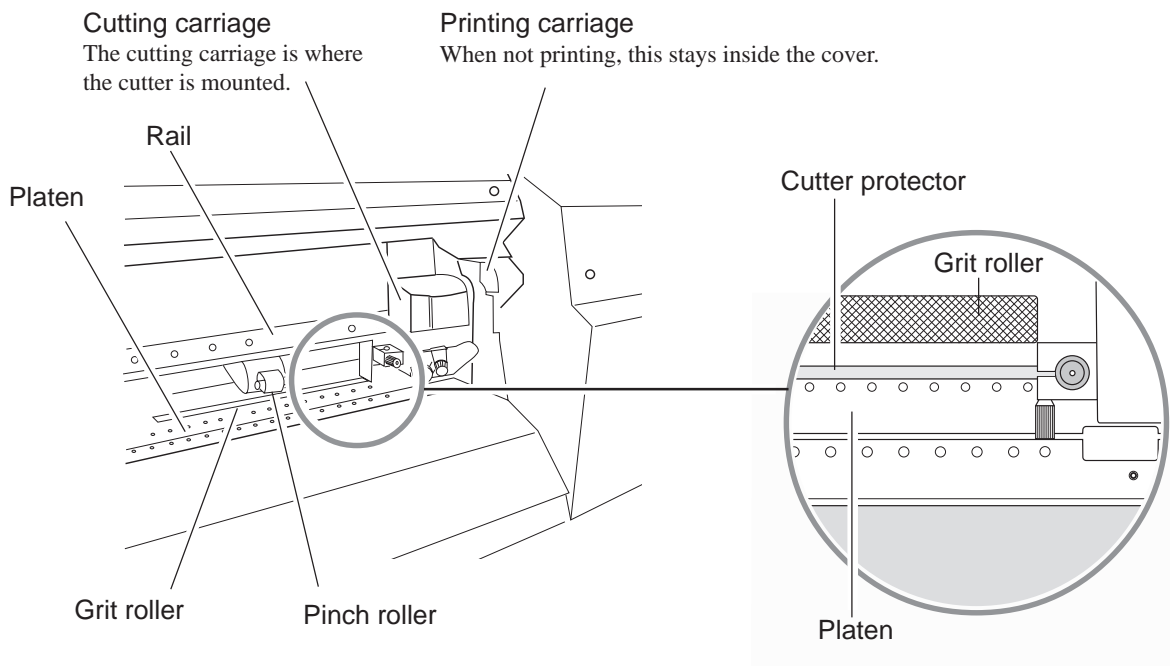

Operation Panel

For more information about the keys, take a look at "Description of Keys".

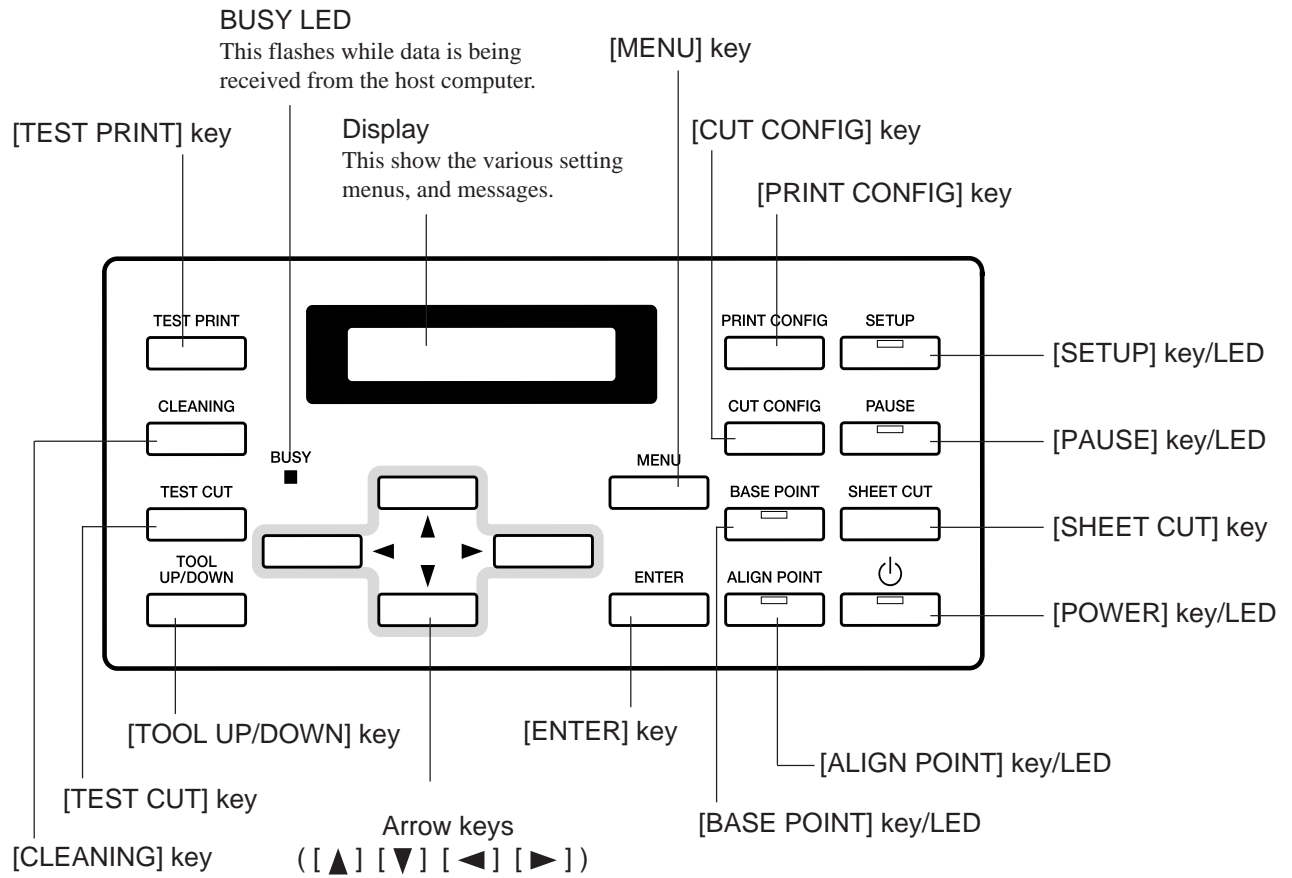

Five Modes

This machine has the following five modes (operating states).

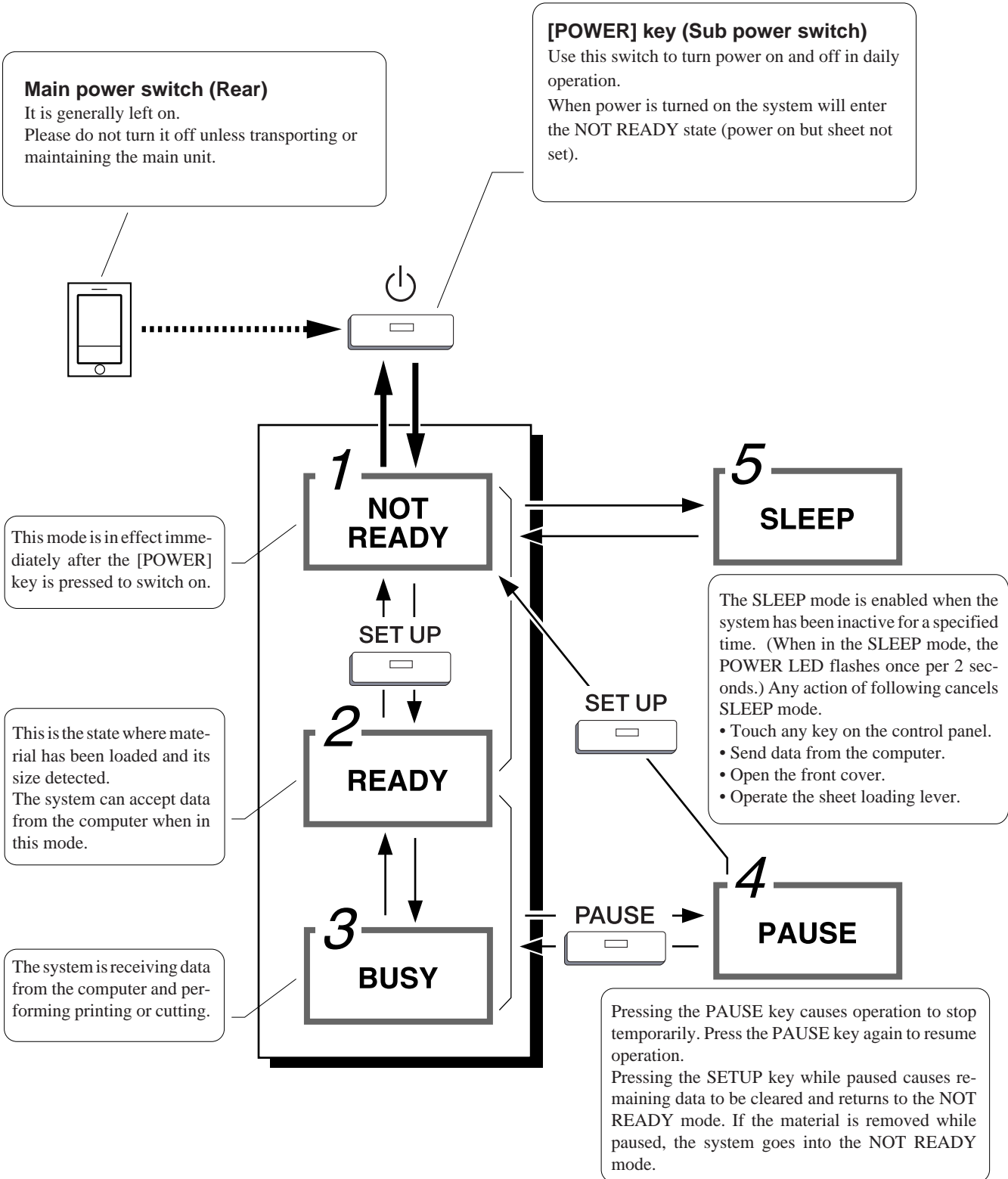

Setup for Printing

1 Loading the Material

⚠ CAUTION



Roll material must be placed at a predetermined shaft position.

Failure to do so may result in falling of the roll, leading to injury.

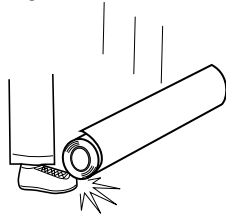

Acceptable material widths

131 to 1371 mm (5-3/16 to 54 in.)

* However, when loading material with a width of 131 to 430 mm (5-3/16 to 17 in.), set the [EDGE SENSE] menu item to [DISABLE].

Loading Roll Material

- 1 Pass the stoppers onto both ends of the shaft. (The shafts (2 pieces), stoppers (2 pieces), and screws (2 pieces) are included with the stand.)

* When passing the shaft through the stopper, be sure to loosen the screws on the stopper first.

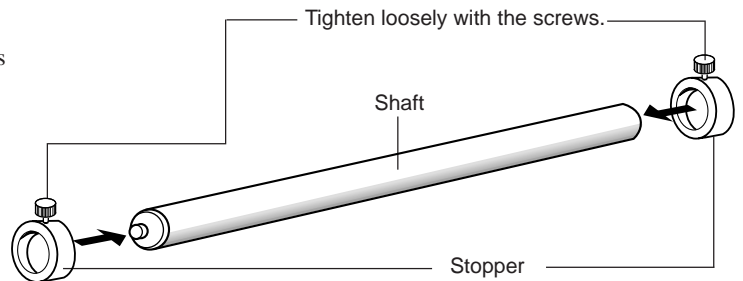

- 2 Attach the media flanges to match the inner diameter of the roll-material core. Insert them firmly, as far as they will go. (The media flange is included with the stand.)

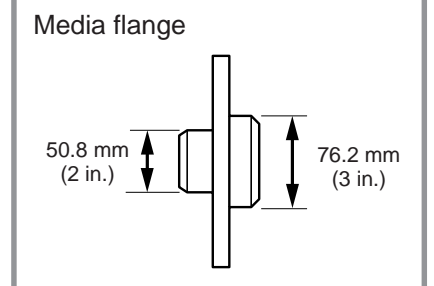
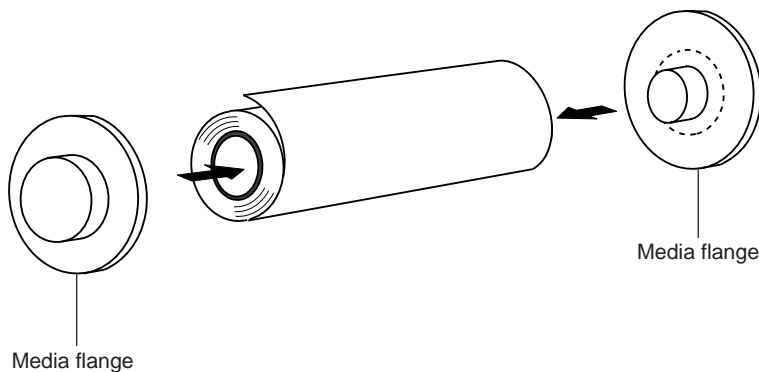

Setup for Printing

- 3** Set the two shafts in place and apply the brake.

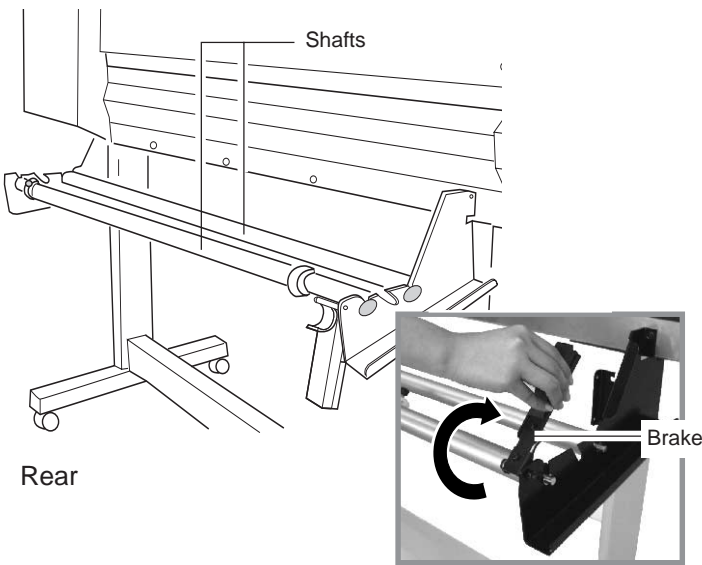

- 4** Place the rolled material on the shaft. Pass the end of the material between the pinch rollers and the grit rollers so that it extends from the front of the unit.

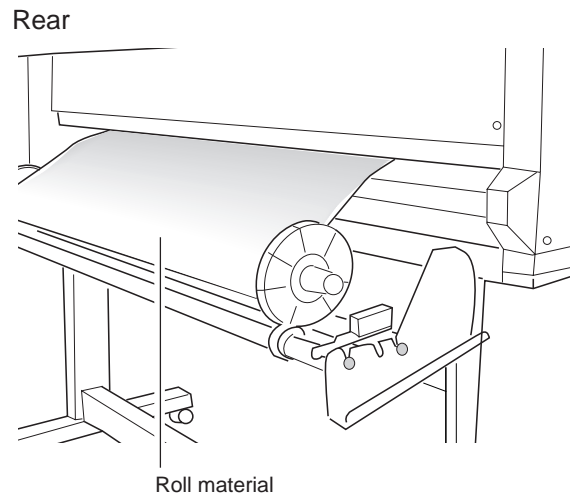

- 5** When viewed from the front, align so that the left-hand edge of the material is above any of the grit rollers and the right-hand edge is above the long grit roller.

- 6** Align the orientation of the material so that it is perfectly straight, and move the left-hand and right-hand pinch rollers so that they are above the grit rollers.

There are two middle pinch rollers, which you can use as required. When you move the pinch rollers to a position over the grit rollers, the pinch rollers descend. Then do not descend when they are moved away from the grit rollers. It is a good idea to use one or both middle pinch roller when the material is wide or when the material is flimsy and prone to wrinkling during material feed. Be sure to lower the left and right pinch rollers.

The white stickers on the rail portion are guides for positioning the grit rollers.

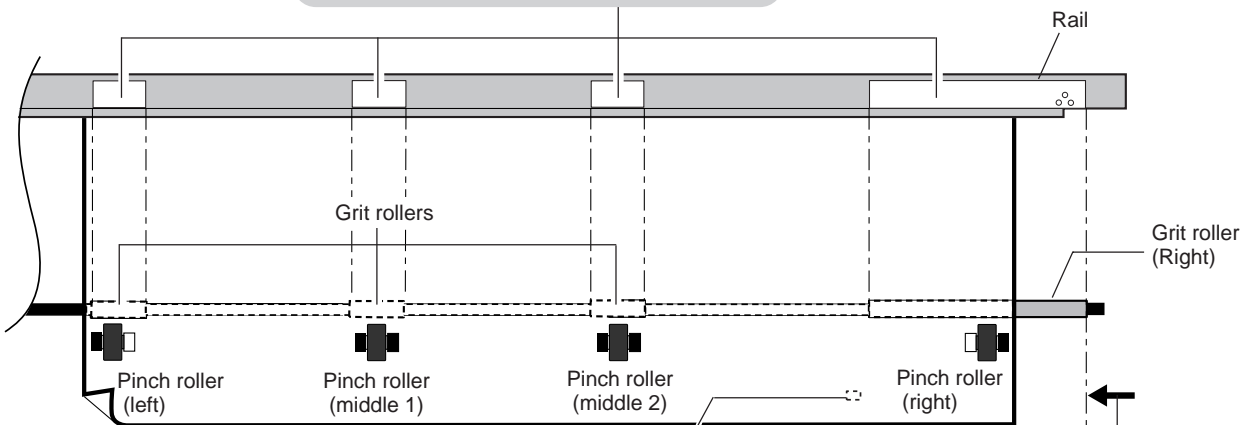

Position the left and right pinch rollers over the material, near the edges.

Pull out the material until it engages the sensor.

Make sure that the right-hand edge of the material does not extend beyond the right-hand edge of the grit roller.



Important note when the middle pinch rollers are lowered

After printing, if the material is returned back to its previous location before it has dried sufficiently, the middle pinch rollers may soil the printed surface. When performing printing and cutting, allow the printed surface to dry sufficiently before attempting to return the material.

- 7** Align the left- and right-hand stoppers with the width of the material and tighten the screws to secure in place.

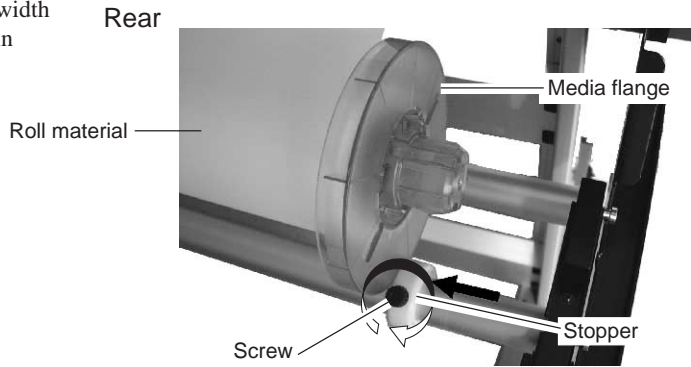

- 8** From the front of the unit, pull the center of material straight out toward the front. Without letting any part of the entire piece of material pulled out to become slack, move the sheet loading lever all the way to "LOAD." The pinch rollers lower to hold the material in place.

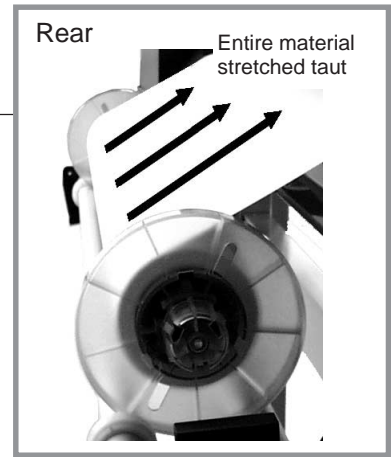
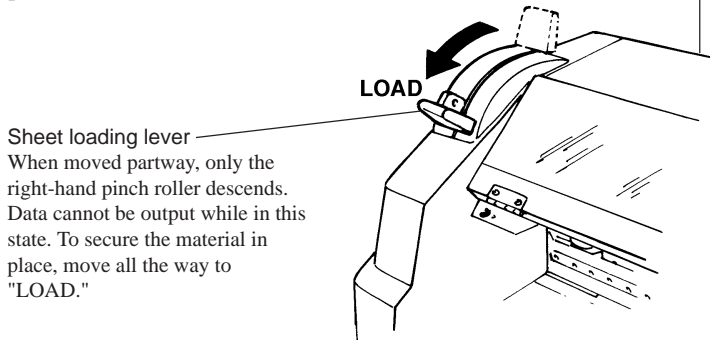

* If there is slackness in the loaded material, the material may move at an angle and come loose from the pinch rollers.

- 9** Close the front cover. Use the [◀] and [▶] keys to select [ROLL], then press the [ENTER] key.

*If printing is to be performed from the edge of the material, select [EDGE] (If [EDGE] does not appear, set [EDGE SENSE] to [ENABLE]).

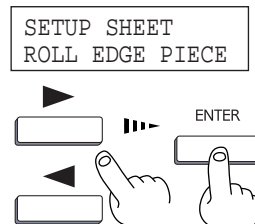

- 10** Press the [SETUP] key. This detects the width of the material and shows the printable width on the display.

*When [EDGE] is selected in step 9, the width of the loaded material is detected, then the front edge of the material is aligned with the print-start location.

The SETUP LED lights up

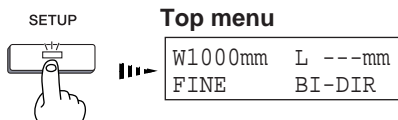

If a pinch roller is positioned over an area where is no grit roller, the message shown at below appears when you press the [SETUP] key.

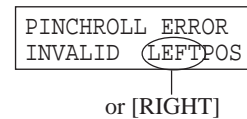

Check the positioning of the pinch rollers and make sure they are aligned at the correct positions.

Loading Flat Material

1 Pass the material between the pinch rollers and the grit rollers as shown in the figure.

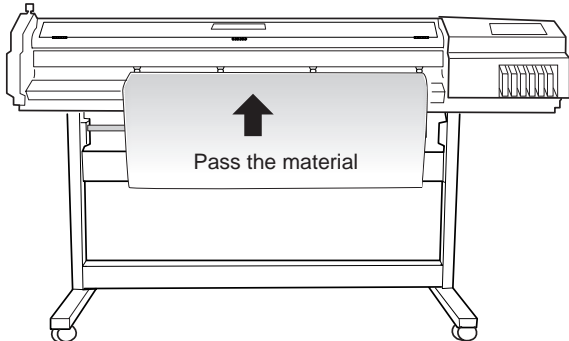

2 Refer to steps 5 and 6 in "Loading Roll Material," and position the material and the pinch rollers correctly.

3 Move the sheet loading lever toward **LOAD**. The pinch rollers lower to hold the material in place.

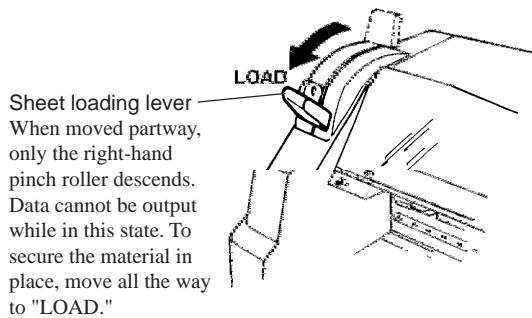

4 Close the front cover. Use the [◀] and [▶] keys to select [PIECE], then press the [ENTER] key.

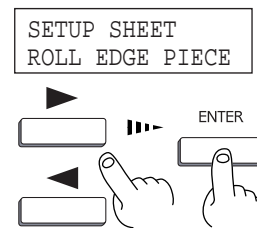

If [PIECE] does not appear, set [EDGE SENSE] to [ENABLE].

5 Press the [SETUP] key. This detects the width and length of the material and shows the printable width and length on the display.

The SETUP LED lights up

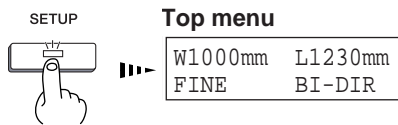

*If the material is misaligned and looks like it might come loose from the pinch rollers, or actually does come loose, please reload the material.

If a pinch roller is positioned over an area where is no grit roller, the message shown at below appears when you press the [SETUP] key.

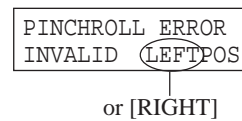

Check the positioning of the pinch rollers and make sure they are aligned at the correct positions.



- When loading flat material, if the material touches the shaft or roll material at the back of the unit, remove the shaft and roll material.
- When thick material is loaded, it may adjust the head height. For more information, see "User's Reference -- Adjusting the Height of the Printing Head."
- When changed to a different type of material, it is necessary to carry out feed correction and bidirectional correction. For more information, see "User's Reference -- Making Corrections for Printing."
- If the sides of the material have warped, then bend back the warp or feed the warped portion to the front and perform setup again. Performing printing with a warped piece of material may cause head smudging or jamming of the material. If the printing heads become damaged or soiled as a result, printing accuracy may suffer.

2 Test Printing

Printing quality is greatly affected by the state of the printing heads.

Before starting to print, you can carry out a printing test to check the state of the printing heads.

If the printing heads are in a poor state and problems such as dot drop-out occur, printing quality drops.

If the test results show a problem, carry out head cleaning to restore the head to its normal state.

1 Load a material, then close the front cover.

2 Hold down the [TEST PRINT] key for 1 second or longer to execute [TEST PRINT].

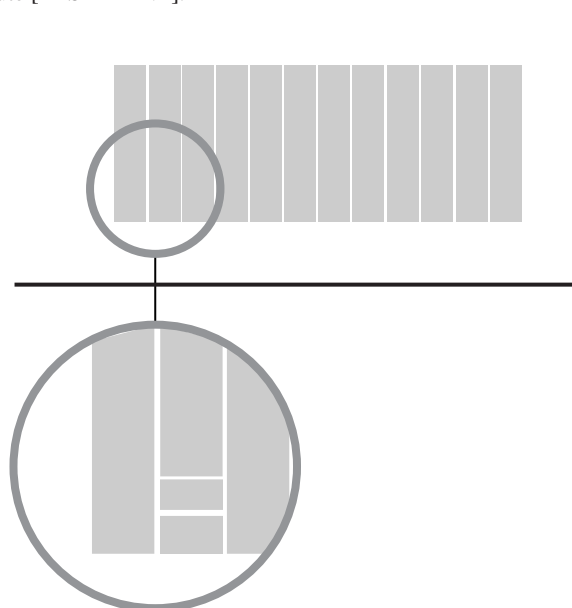
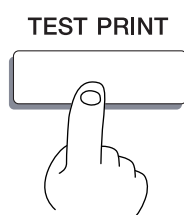

If there are any missing dots or other evidence of a drop in printing quality, clean the head (see "Maintenance -- Cleaning the Printing Heads").

3 Setting the Printing Mode and Printing Direction

Before start to print, set the printing mode and printing direction.
On the control panel, press the [PRINT CONFIG] key and specify the printing mode and direction of printing.



- Printing quality and output time vary according to the printing mode. Choose a mode that matches the task. Note that when the printing mode can be set on the computer, the computer's setting takes priority.
- The printing time for the same original data becomes increasingly longer in this sequence: DRAFT, FAST, NORMAL, FINE, FINE2, SUPER, and PHOTO. Also, with this procedure the size of the output file generally grows larger, and the processing time for creating the output file also becomes longer. It's also necessary to ensure enough memory on the computer.

Printing Mode

- PHOTO:** This is suitable for printing photographs.
- SUPER:** This is suitable for output with high image quality, such as posters.
- FINE:** This is suitable for output with comparatively high detail, such as posters.
- FINE2:** This is suitable for outputting posters and the (Factory like on various materials. default)
- NORMAL:** This is suitable for printing large-size items with comparatively high quality in a short time.
- FAST:** This is suitable for printing large-size items in a short time.
- DRAFT:** This can produce output in the shortest time. It is suitable for checking layout and the like.

Printing Direction

- UNI-DIRECTION:** Unidirectional printing. Printing is performed as the carriage moves from right to left. Printing quality is better than with [BI-DIRECTION].
- BI-DIRECTION (factory default):** Bidirectional printing. Printing is performed as the carriage moves from right to left, and also as it returns from left to right. Printing speed is faster than with [UNI-DIRECTION].

1 Press the [PRINT CONFIG] key.

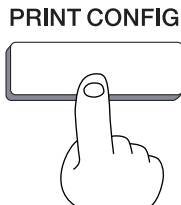

2 Use the [▲] and [▼] keys to choose the printing mode.

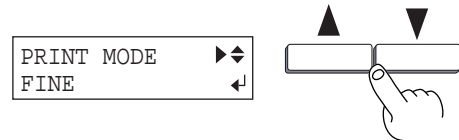

3 Press the [▶] key to make the setting for the printing direction. Use the [▲] and [▼] keys to display the printing direction, then press the [ENTER] key.

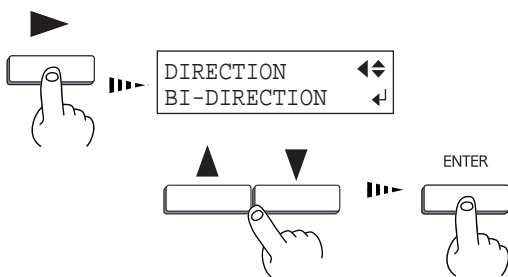

Setup for Cutting

1 Loading the Material

⚠ CAUTION



Roll material must be placed at a predetermined shaft position.

Failure to do so may result in falling of the roll, leading to injury.

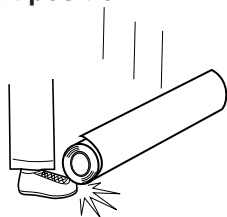

Acceptable material widths

131 to 1371 mm (5-3/16 to 54 in.)

* However, when loading material with a width of 131 to 430 mm (5-3/16 to 17 in.), set the [EDGE SENSE] menu item to [DISABLE].

Loading Roll Material

- 1 Pass the stoppers onto both ends of the shaft. (The shafts (2 pieces), stoppers (2 pieces), and screws (2 pieces) are included with the stand.)

* When passing the shaft through the stopper, be sure to loosen the screws on the stopper first.

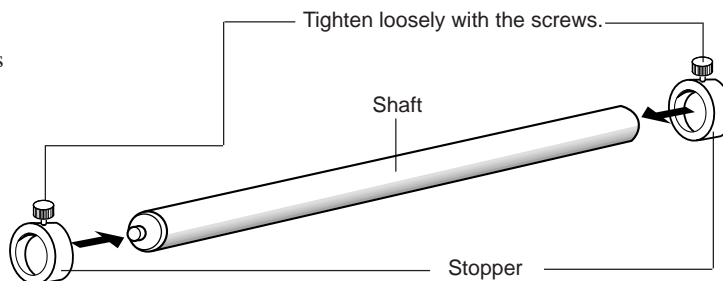

- 2 Attach the media flanges to match the inner diameter of the roll-material core. Insert them firmly, as far as they will go. (The media flange is included with the stand.)

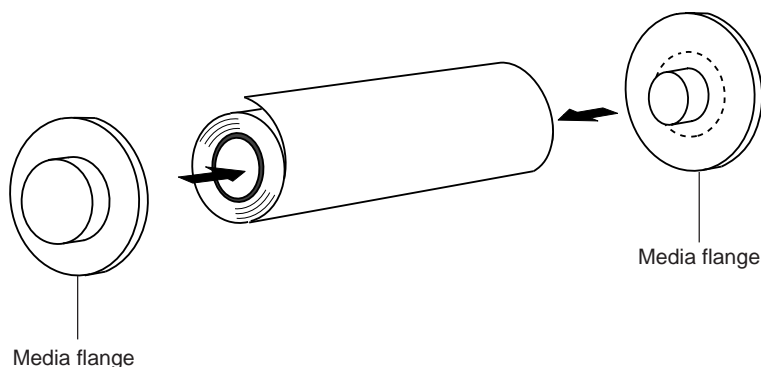

Media flange

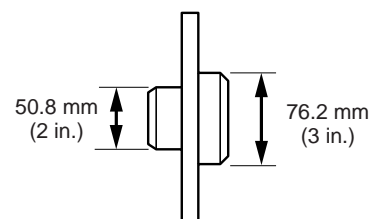

Setup for Cutting

- 3** Set the two shafts in place and apply the brake.

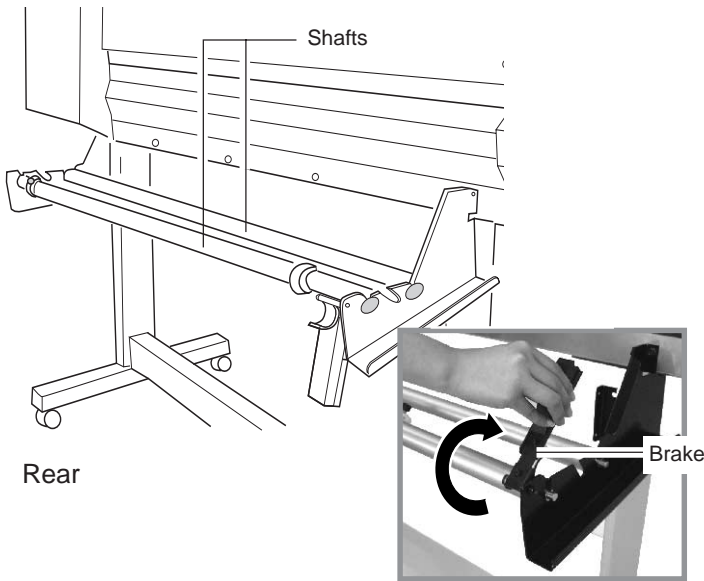

- 4** Place the rolled material on the shaft. Pass the end of the material between the pinch rollers and the grit rollers so that it extends from the front of the unit.

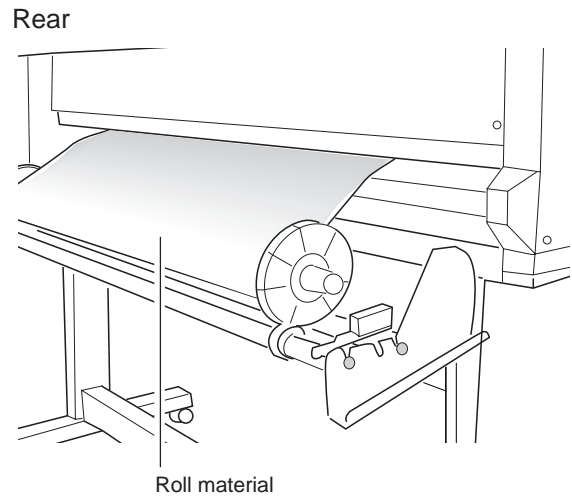

- 5** When viewed from the front, align so that the left-hand edge of the material is above any of the grit rollers and the right-hand edge is above the long grit roller.

- 6** Align the orientation of the material so that it is perfectly straight, and move the left-hand and right-hand pinch rollers so that they are above the grit rollers. There are two middle pinch rollers, which you can use as required. When you move the pinch rollers to a position over the grit rollers, the pinch rollers descend. Then do not descend when they are moved away from the grit rollers. It is a good idea to use one or both middle pinch roller when the material is wide or when the material is flimsy and prone to wrinkling during material feed. Be sure to lower the left and right pinch rollers.

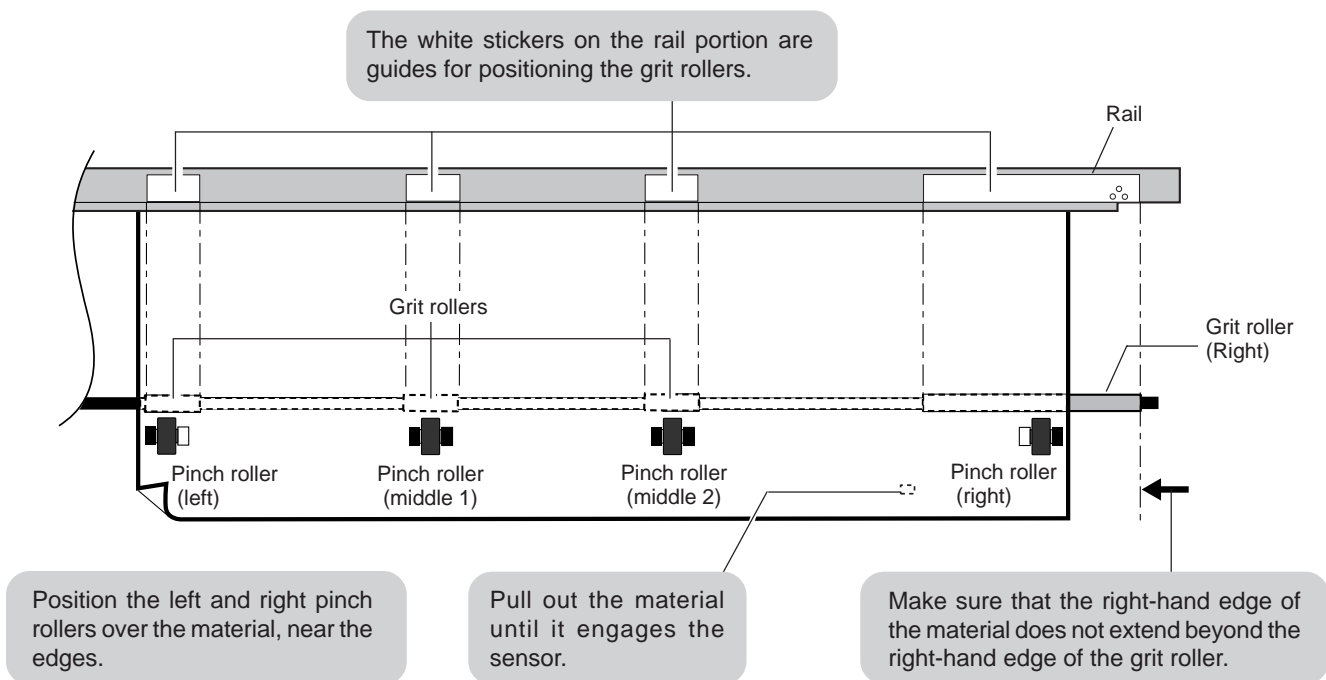

- 7** Align the left- and right-hand stoppers with the width of the material and tighten the screws to secure in place.

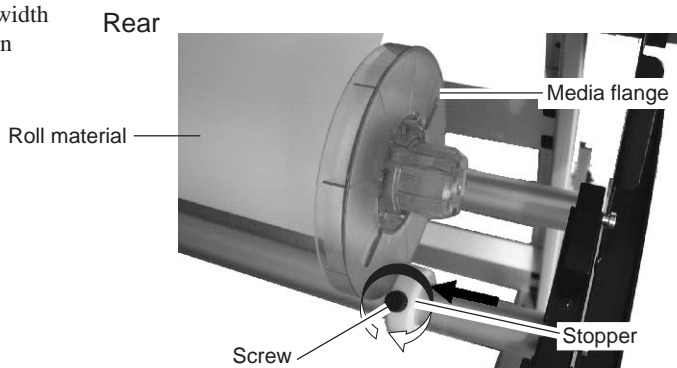

- 8** From the front of the unit, pull the center of material straight out toward the front. Without letting any part of the entire piece of material pulled out to become slack, move the sheet loading lever all the way to "LOAD." The pinch rollers lower to hold the material in place.

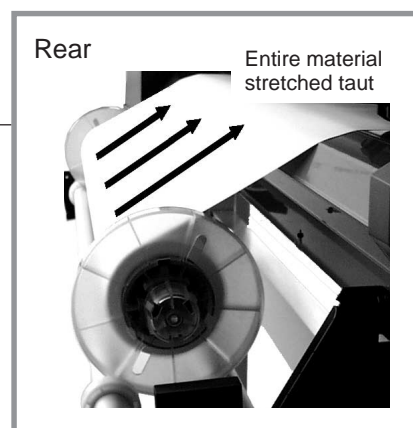
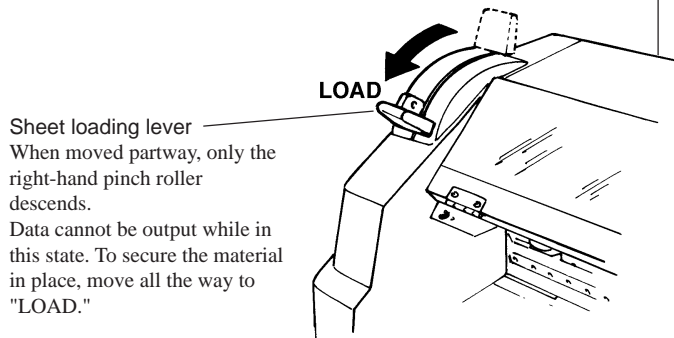

* If there is slackness in the loaded material, the material may move at an angle and come loose from the pinch rollers.



When [PREFEED] is set to [DISABLE], use the arrow keys to feed out the length of material that you want to use. After feeding it out, return it to its original position and leave it loose behind the unit. If cutting is started without doing this first, a motor error may occur or the material roll may fall when the material is pulled out.

- 9** Close the front cover. Use the [◀] and [▶] keys to select [ROLL], then press the [ENTER] key.

SETUP SHEET
ROLL EDGE PIECE

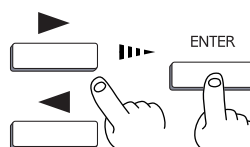

*If cutting is to be performed from the edge of the material, select [EDGE] (If [EDGE] does not appear, set [EDGE SENSE] to [ENABLE]).

- 10** Press the [SETUP] key. This detects the width of the material and shows the printable width on the display.

*When [EDGE] is selected in step 9, the width of the loaded material is detected, then the front edge of the material is aligned with the print-start location.

The SETUP LED lights up



If a pinch roller is positioned over an area where is no grit roller, the message shown at below appears when you press the [SETUP] key.

PINCHROLL ERROR
INVALID (LEFTPOS

or [RIGHT]

Check the positioning of the pinch rollers and make sure they are aligned at the correct positions.

Loading Flat Material

1 Pass the material between the pinch rollers and the grit rollers as shown in the figure.

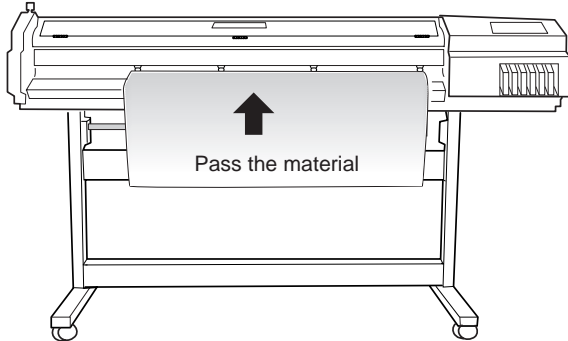

2 Refer to steps 5 and 6 in "Loading Roll Material," and position the material and the pinch rollers correctly.

3 Move the sheet loading lever toward **LOAD**. The pinch rollers lower to hold the material in place.

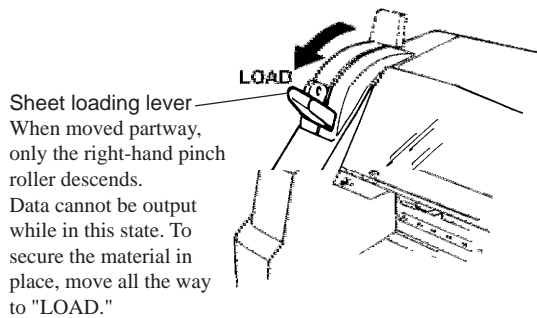

4 Close the front cover. Use the [◀] and [▶] keys to select [PIECE], then press the [ENTER] key.

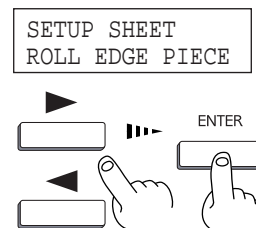

If [PIECE] does not appear, set [EDGE SENSE] to [ENABLE].

5 Press the [SETUP] key. This detects the width and length of the material and shows the printable width and length on the display.

The SETUP LED lights up

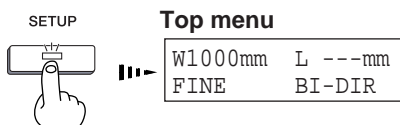

If a pinch roller is positioned over an area where is no grit roller, the message shown at below appears when you press the [SETUP] key.

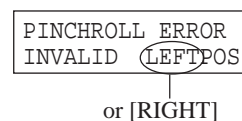

*If the material is misaligned and looks like it might come loose from the pinch rollers, or actually does come loose, please reload the material.



- When loading flat material, if the material touches the shaft or roll material at the back of the unit, remove the shaft and roll material.
- If the sides of the material have warped, then bend back the warp or feed the warped portion to the front and perform setup again.

2 Installing a Blade

⚠ CAUTION



Do not touch the tip of the blade with your fingers.

Doing so may result in injury, and the cutting performance of the blade will be impaired.

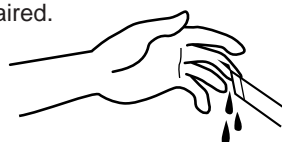

NOTICE Be sure to support the tool mounting screw from below when installing the blade holder. Cutting quality may become poor if installed without supporting the screw in this way.

- 1** Insert a blade into the blade holder until it snaps into place with an audible click.

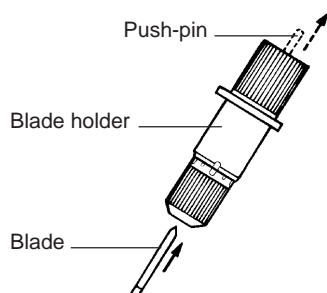

- 2** Adjust the amount of blade extension as shown in figure to find the optimal amount of blade for the target material.

Turning the tip by an amount corresponding to one large scale gradation extends the blade by 0.1 mm (0.00394 in.).

Adjustment for 0.5 mm (0.0197 in.) can be made by rotating the cap one full turn.

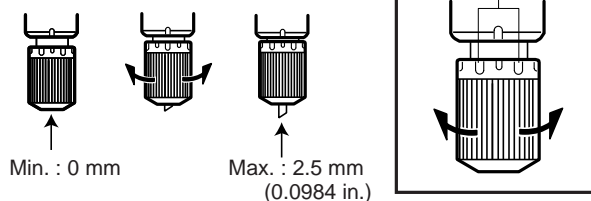

- 3**
- (1) Loosen the tool securing screw on the cutting carriage.
 - (2) Support the tool-securing screw from below and install the blade holder. Insert the blade holder until the collar is flush with the carriage.
 - (3) Tighten the tool securing screw until the blade holder is secured in place.

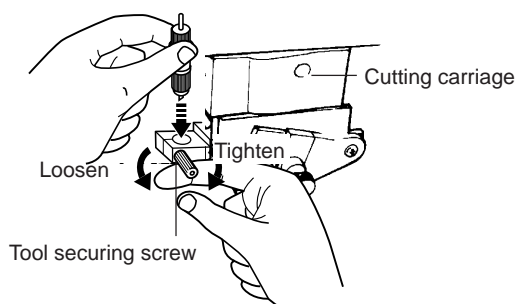

3 Test Cutting

Cutting quality is affected by the blade and material being used, and by the cutting conditions. There are four cutting conditions: “cutting speed,” “blade force,” “blade offset,” and “amount of blade extension.” For high-quality cutting, it is necessary to set the appropriate cutting conditions for the blade and material in actual use.

The cutting test is a feature for checking beforehand whether these cutting conditions are appropriate.

1 Install a blade and load a material, then close the front cover.

2 Use the [▲], [▼], [◀] and [▶] keys to move the tool carriage to the place where the test cutting is to be performed.

3 Press the [TEST CUT] key for 1 second or longer. Test cutting starts.

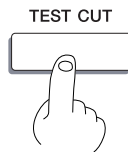

4 Examine the cutting results for the material and diagnose the cutting conditions.

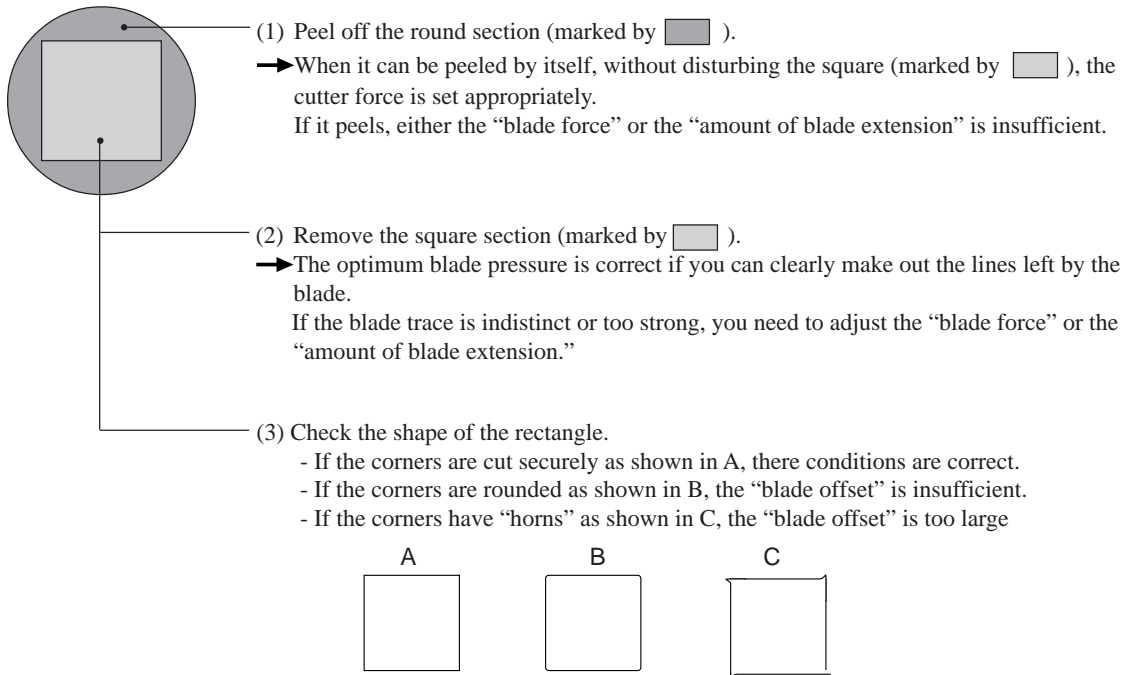

If the test cutting shows problems with the material cutting results, adjust the cutting conditions.

For “cutting speed,” “blade force,” and “blade offset,” press the [CUT CONFIG] key and set the cutting conditions.

For “amount of blade extension,” refer to “Setup for Cutting -- 2 Installing the Blade.”

Repeat the cutting tests and adjustment of the cutting conditions until you obtain good cutting results for the material.



When [COMMAND] on the display menu has been set to [ENABLE], the program’s settings for the cutting conditions take priority.
 To give priority to the cutting conditions set on the machine, turn off the program settings, or set the [COMMAND] menu to [DISABLE].
 For more information about the [COMMAND] menu, see the section “Descriptions of Menu Items - Description of Menus.”

Incorrect cutting conditions may cause symptoms such as those described below.

Blade force

- The material is easily torn.
- The cutter requires frequency replacement.
- Cutting extends through the base paper, and normal advancing of the material becomes impossible.
- The unit suffers damage.

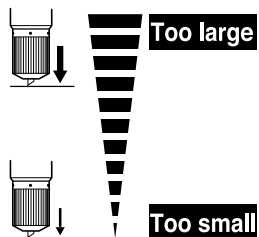

Some parts of the material remain uncut.

Blade offset

Corners flare outward, with "horns."

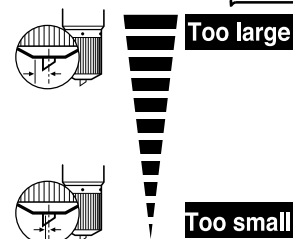

Corners are rounded.



For Materials with a Strong Adhesive Layer

If you are using a material with a strong adhesive layer, the adhesive layer may adhere to itself immediately when cut. This means that even though the material has actually been cut, it may appear as if it has not been cut, and blade force may mistakenly be set too high.

If a cutting test shows that the material peels easily and the blade traces on the carrier paper are optimal, then the material is being cut. Take care not to set the blade force excessively high.

Setup for Printing and Cutting

Before performing printing and cutting, set up the machine as follows.

1 Loading the Material

Refer to “Setup for Printing -- 1 Loading the Material” and load the material correctly.

2 Installing a Blade

Refer to “Setup for Cutting -- 2 Installing the Blade” and install the blade correctly.

3 Test Printing

Refer to “Setup for Printing -- 2 Printing Test” and check the state of the heads.

4 Setting the Printing Mode and Printing Direction

Refer to “Setup for Printing -- 3 Selecting the Printing Mode and Direction of Printing” and make the settings for the modes.

5 Test Cutting

Refer to “Setup for Cutting -- 3 Cutting Test” and perform a cutting test and adjust the cutting conditions.



When cutting is performed after printing, the cap tip of the blade holder may scratch the printed surface. If this is the case, lengthen the cutter blade extension.

Also, when time is required for the printed surface to dry, you can ensure an automatic wait for a fixed interval after printing before cutting starts. For detailed information, go to the "Description of Menu Items" chapter, and under "Description of Menus," see [DRYING TIME]. Note that in cases where you can also make this setting using the program, the setting made here takes priority. Check the documentation for the program.

Downloading Printing/Cutting Data

NOTICE Opening the front cover while printing is in progress causes an emergency stop. This means that printing may not be carried out correctly even if operation is resumed, due to drop-out or misalignment of the image. To pause printing for any other reason than an emergency stop, press the [PAUSE] key. Note pressing the [PAUSE] key to pause operation may result in differing image quality before and after the pause. It is a good idea to avoid pausing operation while printing is in progress whenever possible.

If you will leave the printing head being uncapped for a long time (for example, open the front cover while printing is made on the middle of platen), printing heads may get clogging and, in some case it results unrecoverable damage to the printing head.

Printing or cutting is started when data is sent.

If the top menu isn't displayed, printing or cutting doesn't start even when data is sent from the computer.

Conditions for starting printing or cutting

The material must be already set up (with the SETUP LED lighted), and the display must show the top menu.

Top menu

W1234mm	L ---mm
FINE	BI-DIR

If another menu screen is displayed, press the [SETUP] key to go back to the top menu.

(Pressing the [SETUP] key when another menu screen is displayed does not cancel the set-up for the material.)

If the data sent from the computer is wider than the printing/cutting area of the loaded material, the message at right appears and operation stops.

To ignore this message and continue printing, press the [ENTER] key. Note that the portion outside the printing/cutting area is not outputted.

To stop outputting, stop sending data from the computer, then press the [SETUP] key. Increase the printing/cutting area by replacing with a larger piece of material or changing the positions on the pinch rollers, then send the data again.

SHEET TOO SHORT CONTINUE?

Pausing Printing or Cutting Operations

Press the [PAUSE] key.

The PAUSE LED lights up

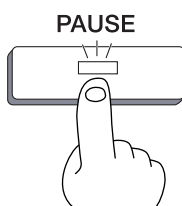

To resume printing

Press the [PAUSE] key.

The PAUSE LED goes out

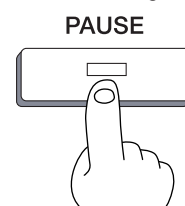

Stopping Printing or Cutting Operations

1 Press the [PAUSE] key.

The PAUSE LED lights up

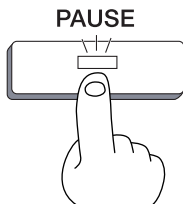

2 Halt transmission of print or cutting instructions from the computer.

3 Hold down the [SETUP] key for one second or longer. Any remaining data is cleared.

The SETUP LED goes out

SETUP

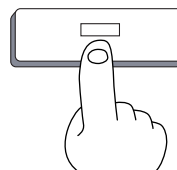

* Clearing the data may take some time.

If the "INK EMPTY" message appears while printing

If it becomes necessary to replace the ink cartridge while printing is in progress, the buzzer sounds and the following message is displayed. Please replace the ink cartridge.

If this message is ignored and printing is continued without replacing the ink cartridge, image quality may be adversely affected and exhibit faintness or other problems.

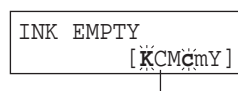

This indicates the ink color. The color for which ink has run out flashes.

K = Black / C = Cyan / M = Magenta /
c = Light Cyan / m = Light Magenta /
Y = Yellow

1 When [INK CONTROL]'s [EMPTY MODE] is set to [LATER]

Press the [PAUSE] key to pause printing.

The PAUSE LED lights up

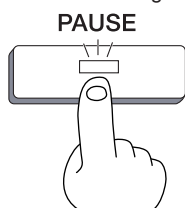

2 Pull out the cartridge for the ink color that has run out, and replace with a new cartridge (see "Replacing the Ink Cartridges").

3 Press the [PAUSE] key to resume printing.

The PAUSE LED goes out

PAUSE

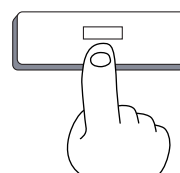

When [INK CONTROL]'s [EMPTY MODE] is set to [PROMPT]

The unit pauses automatically.

About the [EMPTY MODE]

When replacement of the ink cartridge becomes necessary while printing is in progress, this setting determines whether printing continues or pauses.

This setting is used when the ink cartridge cannot be changed immediately during printing, such as during unattended operation at night. [LATER] causes printing to continue without pause even if ink refilling becomes necessary. Printing continues with the small amount of ink remaining, so the printed image may become faint as the ink runs out. In general, it should be possible to perform about 1 m² (10 ft²) of printing once this message appears, although the actual varies widely according to the amount of ink needed for the particular image. Printing is continued only for the data currently being printed. Operation stops after one image is output.

[PROMPT] causes operation to pause immediately when the ink cartridge needs to be changed. Printing is resumed by replacing the cartridge and pressing the [PAUSE] key. Please note, however, that the colors of an image in progress may no longer be perfectly matched if the unit is allowed to remain paused for two or three hours before resuming printing.

Remove the Material

Remove the Material from the machine

- 1** Press the [SETUP] key. Hold down for about 1 second.

The SETUP LED goes out

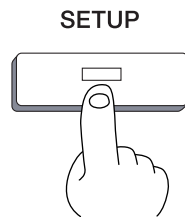

- 2** Move the sheet loading lever toward the back of the unit. The pinch rollers rise to release the material.

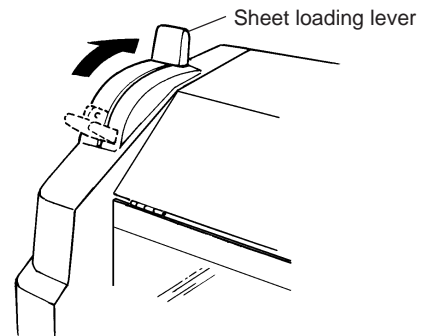

- 3** Open the front cover. To remove the material.

Cut the material from the roll

Either of two methods can be used to separate a portion that's already been cut or printed from the roll. One method is to press the [SHEET CUT] key. The other method is to perform separation automatically by sending a material-cutting command from the computer.

When separating the material by pressing the [SHEET CUT] key

Holding down the [SHEET CUT] key for 1 second or longer severs the material at the present location of the blade tip.

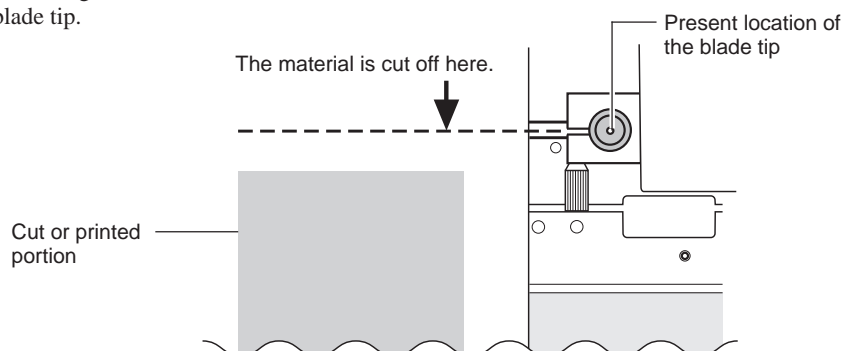
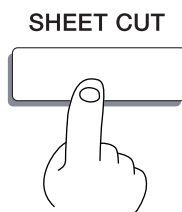

* This operation isn't necessary when sending a material-cutting command from the computer to separate the material automatically.

When sending a material-cutting command from the computer to separate the material automatically

* When the material-cutting command has not been set to "enabled" at the computer, automatic separation of the material is not performed, even when the following setting is made.

- 1** Press the [MENU] key and [▼] key to make the following screen appear on the display.

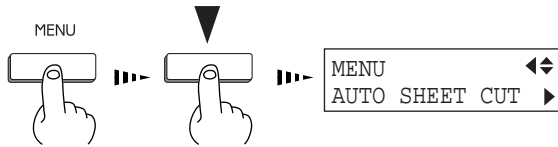

- 2** Press the [▶] key to make the following screen appear on the display.

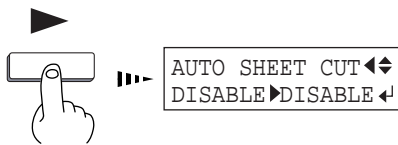

- 3** Use the [▼] key to select [ENABLE], then press the [ENTER] key.

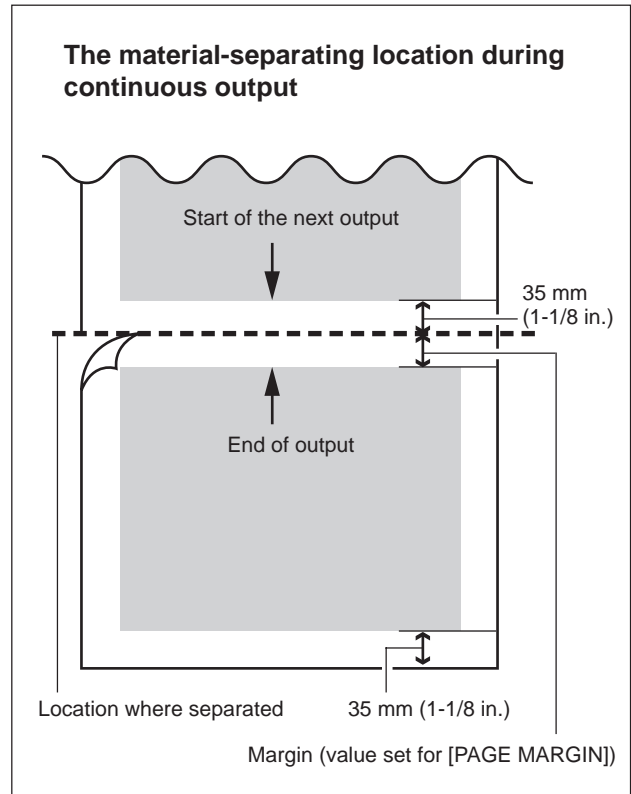
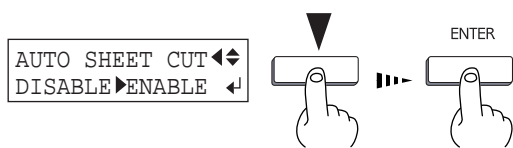

When Operations Are Finished

NOTICE Even when not in use, keep the machine in an environment where the temperature is 5 to 40 °C (41 to 104 °F) and the humidity is 20 to 80 % (no condensation). In particular, be careful to make sure not to expose the machine to high temperatures of 40 °C (104 °F) or more.

When operations are finished, move the sheet loading lever toward the back of the unit to raise the pinch rollers. The pinch rollers may be deformed if allowed to remain in the lowered state.

- 1** If the SETUP LED is lighted, press the [SETUP] key. Hold down for about 1 second.

The SETUP LED goes out

SETUP

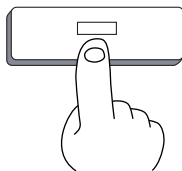

- 2** Move the sheet loading lever toward the back of the unit and remove the material.

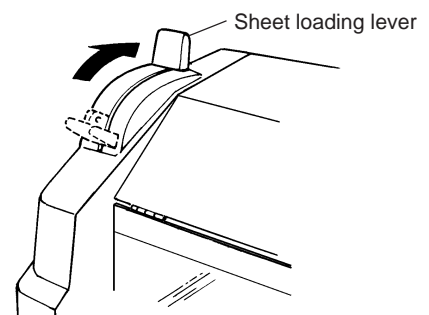

- 3** Remove the blade holder from the cutting carriage.

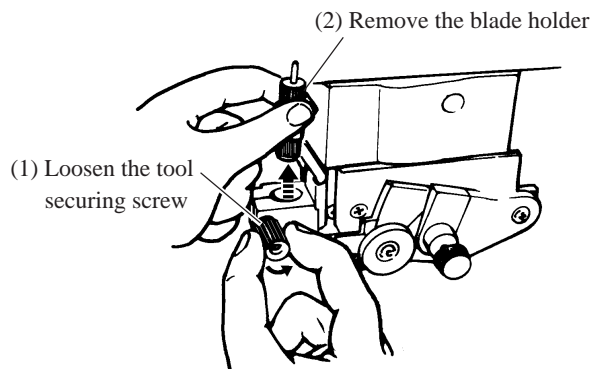

- 4** Remove the blade.

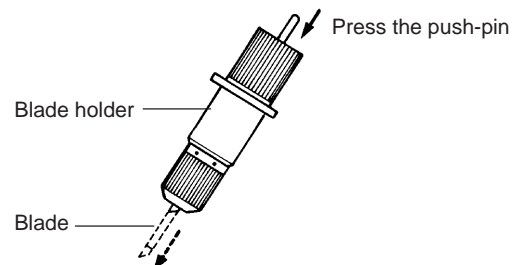

- 5** Press the [POWER] key to switch off the power. The carriage moves to the standby position and the head is capped. If the carriage is already at the standby position, no movement takes place.

The POWER LED goes out

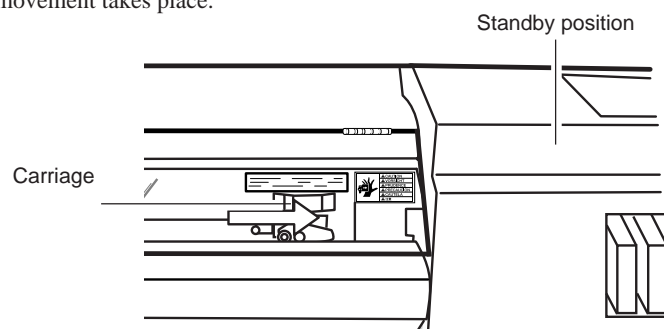
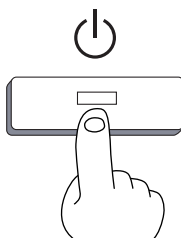

Maintenance

Replacing the Ink Cartridges

WARNING



Do not operate in a location exposed to open flame, sparking, or static electricity, or in a location exposed to high temperatures, such as in the immediate vicinity of a heater. Also, do not place undried media in such locations.

Doing so may result in fire due to combustion of ink or cleaning liquid.



Do not store ink cartridges, cleaning liquid, or discharged ink in locations such as the following.

- Near open flame
- Locations exposed to high temperatures, such as in the immediate vicinity of a heater
- Near bleach, chemicals, explosives, or the like

Doing so may cause fire.

CAUTION



Ensure adequate ventilation for the work area.

Failure to do so may result in odor, physical distress, or fire.



Do not allow ink or cleaning liquid to come into contact with eyes or skin. Do not drink or deliberately smell ink or cleaning liquid.

Doing so may be hazardous to your health.



Store ink cartridges out of the reach of children.

NOTICE

Do not use anything other SOL INK cartridges. Do not attempt to refill and reuse an empty ink cartridge.

Do not remove any ink cartridges except when shipping the machine.

If ink runs out, replace immediately with the same type and the same color ink cartridge. If an ink cartridge is removed, replace it immediately with a new one.

Do not attempt to disassemble an ink cartridge.

Store ink cartridges unopened at a temperature of -20 to 40 °C (-4 to 104 °F) in a well-ventilated location.

If an ink cartridge is dropped, the shock due to the fall may damage the ink cartridge and make it unusable.

When removing an ink cartridge, do not rush. Detach the cartridge gently. Sudden movement when detaching may cause ink to be spilled.



Once an ink cartridge has been installed, do not remove it until the ink has been used up. Frequent insertion and removal may allow air to enter the ink tube and result in a drop in printing quality due to dot drop-out or the like.

NOTICE Use only SOL INK. Do not insert any other type of ink cartridge.

1 Remove the ink cartridge from the ink-cartridge port.

2 Insert new ink cartridge.

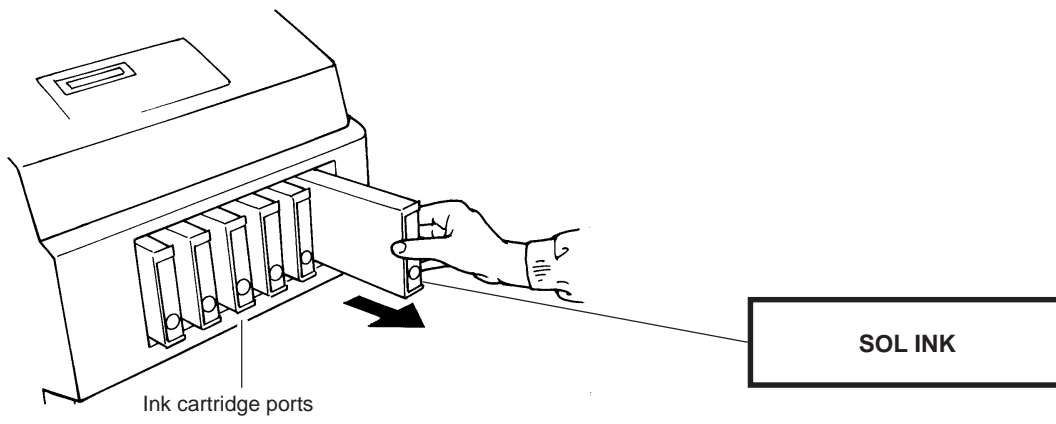

Check how much ink remains

You can use [INK LEFT] on the display menu to check how much ink is left after the ink cartridges have been installed. Use this information as a guide for replacing the ink cartridges. If a partially used ink cartridge is removed and reinstalled, or if a partially used ink cartridge is installed, the cartridge is taken to be unused, and the displaced amount of remaining ink is not true.

- 1 Press the [MENU] key and [▼] key to make the following screen appear on the display.

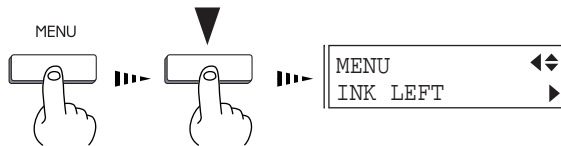

- 2 Press the [▶] key to make the following screen appear on the display. The fewer the markers, the less is the amount of ink left.

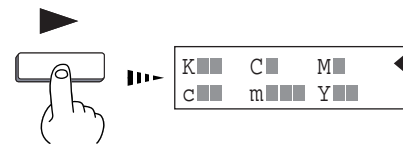

K = Black / C = Cyan / M = Magenta /
 c = Light Cyan / m = Light Magenta /
 Y = Yellow

 Remaining ink

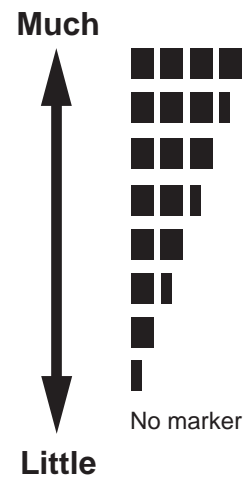

Cleaning the Printing Heads

Switching on the sub power automatically performs maintenance operations, including cleaning of the printing head. This means that there is normally no need to perform cleaning otherwise.

If drop-out occurs with printed images, clean the printing head.

* After cleaning, carry out a printing test. Load material.



The cleaning causes a certain amount of head wear and also consumes a certain amount of ink, so use should be kept to a minimum.

[POWERFUL] results in faster head wear and also uses up much ink. (Performing cleaning from the [POWERFUL] menu uses up about 57 cc of ink for six colors. This is because the process discharges all ink in the ink tube and replaces it with fresh ink.)

- 1 Hold down the [CLEANING] key for 1 second or longer to start head cleaning.



- 2 When head cleaning finishes, hold down the [TEST PRINT] key for 1 second or longer to perform a printing test (see "Setup for Printing -- Test Printing").

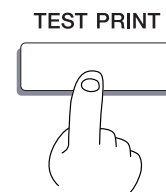

- 3 Check the printing-test results. If a problem is found, repeat the cleaning.

If drop-out persists even after carrying out cleaning several times

- 1 Press the [MENU] key and [▼] key to display [HEAD CLEANING], then press the [▶] key.

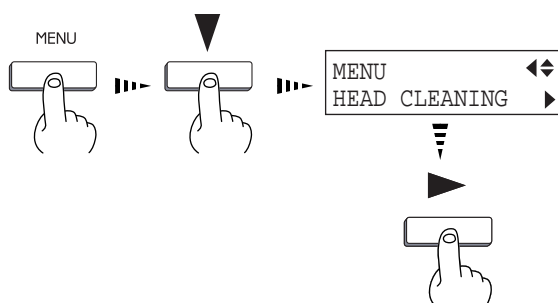

- 2 Use the [▲] and [▼] keys to select either [MEDIUM] or [POWERFUL], then press the [ENTER] key. Head cleaning starts.

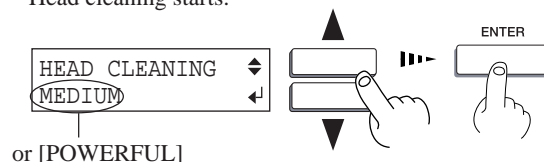

*The cleaning function increases in this sequence.

- When the [CLEANING] key is pressed
- The [MEDIUM] menu item on the [HEAD CLEANING] menu
- The [POWERFUL] menu item

- 3 When head cleaning finishes, hold down the [TEST PRINT] key for 1 second or longer to perform a printing test (see "Setup for Printing -- Test Printing").

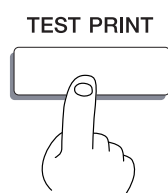

- 4 Check the printing-test results. If a problem is found, repeat the cleaning.

If image drop-out is not corrected even when cleaning has been performed several times from the [POWERFUL] menu

If image drop-out is not corrected even when cleaning has been performed several times from the [POWERFUL] menu, use the included cleaning kit. For information on how to use the cleaning kit, refer to the documentation included with the kit.

If cleaning with the cleaning kit does not correct image drop-out, consult your authorized Roland DG Corp. dealer or service center.

Replacing the Cutter Blade

⚠ CAUTION



Do not touch the tip of the blade with your fingers.

Doing so may result in injury, and the cutting performance of the blade will be impaired.



1 Remove the blade holder from the cutting carriage.

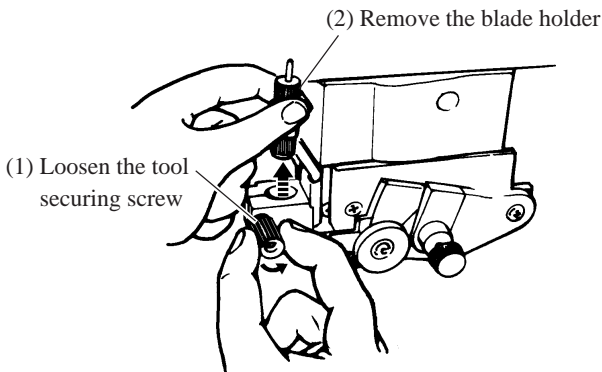

2 Remove the old blade.

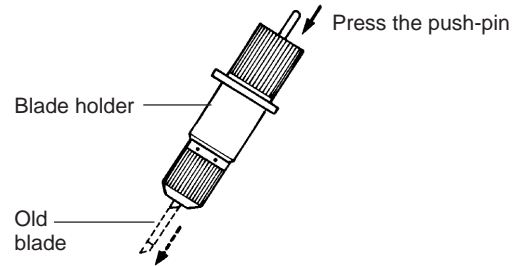

3 Replace with a new blade.

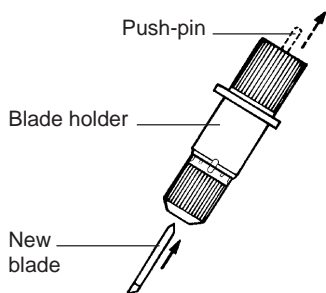

4 (1) Loosen the tool securing screw on the cutting carriage.
(2) Support the tool-securing screw from below and install the blade holder. Insert the blade holder until the collar is flush with the carriage.
(3) Tighten the tool securing screw until the blade holder is secured in place.

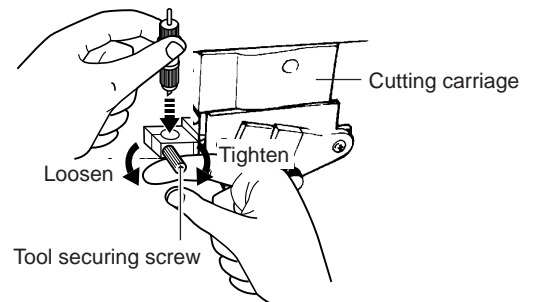

How to Replace the Separating Knife

⚠ CAUTION



Do not touch the tip of the blade with your fingers.

Doing so may result in injury, and the cutting performance of the blade will be impaired.



Make sure the power to the unit is off before attempting to replace the separating knife.

Doing so may result in injury.

If the separating knife, replace it with the replacement blade.

- 1** Press the [POWER] key to switch off the power.

The POWER LED goes out

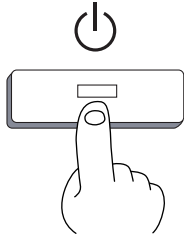

- 2** Turn off the main power switch.

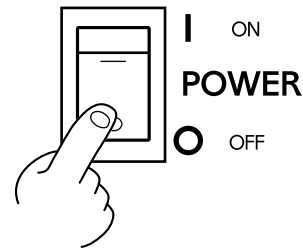

- 3** Remove the separating knife.
 (1) Loosen the screw until it slips out.
 (2) Grasp the screw portion, and slowly pull it out in the direction of the arrow.
 * Do not pull back while doing this.

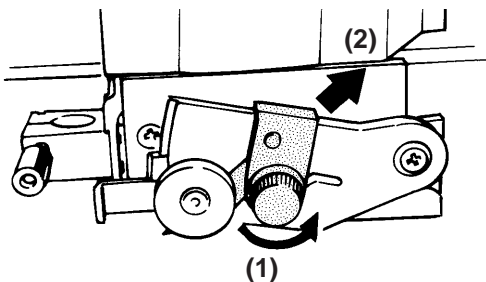

If the blade remains in the carriage, use commercially available tweezers to remove it.

- 4** Replace with a new knife.

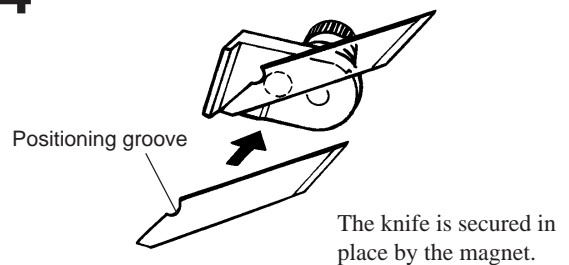

- 5** Install the separating knife.
 (1) Grasp the screw portion and slowly insert it into the groove.
 * Take care to ensure that the knife does not slip
 (2) Tighten the screw.

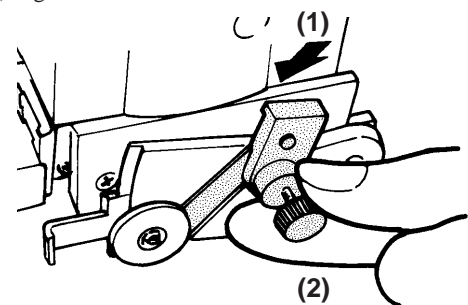

When the Product Needs Cleaning

NOTICE

When performing cleaning, turn off the main power switch.

* Before turning off the main power, press the [POWER] key to switch off the sub power.

Never lubricate the mechanisms.

Do not clean with solvents (such as benzine or thinners).

Periodically clean the platen. Attractive printing may become impossible if the platen is soiled.

Do not touch the printing heads or allow the printing heads to come in contact with anything except ink.

Cleaning the body

Use a cloth moistened with water then wrung well, and wipe gently to clean. Wipe the operation panel and display gently with a clean, dry, and soft cloth.

Cleaning the platen

Use a cloth moistened with water then wrung well, and wipe gently to clean.

Cleaning the grit rollers

Use a commercially available brush to remove dust and other detritus. Brush horizontally while rotating the grit rollers.

Any adhering grime may prevent the material from being held in place securely.

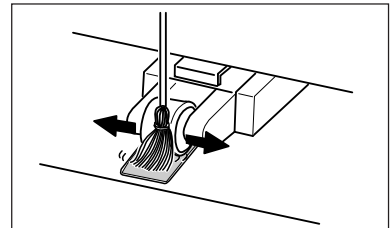

Cleaning the pinch rollers

Use a cloth moistened with water then wrung well, and wipe gently to clean.

Cleaning the front cover

Use a cloth moistened with water then wrung well, and wipe gently to clean.

Cleaning the blade holder cap

If material debris is adhering to the inner surface of the cap for the blade holder, loosen and remove the cap, then remove the material debris.

When Not in Use for a Prolonged Period...

NOTICE Even when not in use, keep the machine in an environment where the temperature is 5 to 40 °C (41 to 104 °F) and the humidity is 20 to 80 % (no condensation). In particular, be careful to make sure not to expose the machine to high temperatures of 40 °C (104 °F) or more.

When not in use, move the sheet loading lever toward the back of the unit to leave the pinch rollers in the up position state. The pinch rollers may be deformed if allowed to remain in the lowered state.

When the machine is out of use for an extended period, then once a month, switch on the power and perform cleaning. When the machine's main power switch is left on, a warning beep sounds about once a month to remind you to perform cleaning. We recommend switching off only the sub power and leaving the main power on even when the machine is out of use for an extended period.

- 1** When the machine is out of use for about a month, a warning beep sounds and the following message appears on the display.

PRESS THE POWER
KEY TO CLEAN

- 2** Press the [POWER] key to switch on the sub power. Cleaning is performed automatically.

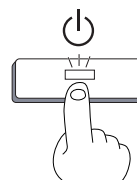

The POWER LED
lights up

- 3** After cleaning has finished, hold down the [POWER] key for 1 second or longer to switch off the sub power.

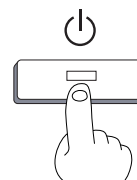

The POWER LED
goes out

When Moving the Unit...

NOTICE When moving the unit, first carry out head washing, then secure the carriage in place.

Head cleaning requires three SOL INK cleaning cartridges, which are optionally available. Be sure to use SOL INK cleaning cartridges. Use of any other type may result in breakdown.

1 If there is material loaded, hold down the [SETUP] key for 1 second or longer to cancel setup, then remove the material (see "Remove the Material").

2 Press the [MENU] key and [▼] key to make the following screen appear on the display.

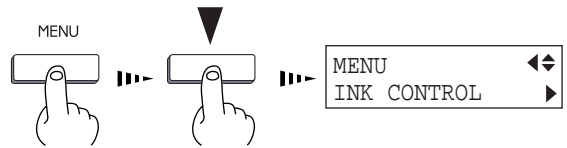

3 Press the [▶] key to make the following screen appear on the display.



4 Use the [▼] key to select [HEAD WASH], then press the [ENTER] key.



5 When the display shown in the figure appears, discard the discharged ink in the drain bottle.
 * Be sure to discard the discharged ink.
 Attempting to head washing while discharged ink remains may cause discharged ink to overflow from the bottle.



6 Mount the drain bottle and press the [ENTER] key to display the screen shown in the figure.



7 When all ink cartridges have been removed, head washing starts. Follow the messages on the display to carry out the procedure.

Messages appearing during head washing



Insert a cleaning cartridge into the ink cartridge port for the flashing color.



Remove the cleaning cartridge from the ink cartridge port for the flashing color.

K = Black C = Cyan M = Magenta c = Light Cyan
 m = Light Magenta Y = Yellow

8 When the display shown in the figure appears, head washing is finished. Press the [POWER] key to switch off the sub power.

The POWER LED goes out

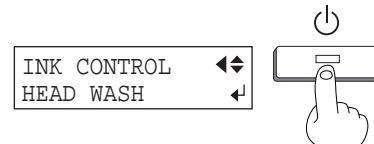

9 When the POWER LED goes out, turn off the main power switch.

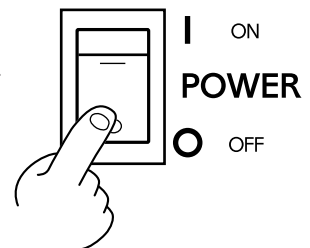

Continued on the next page

10 Detach the power cord and the cable connecting the unit to the computer.

11 Remove the drain bottle.

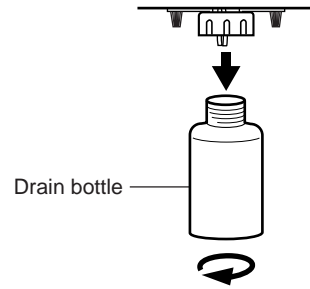

12 Remove the drain-bottle cap.

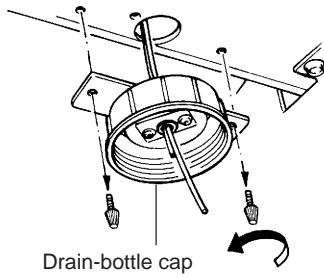

13 Attach the tube plug to the tube tips instead.

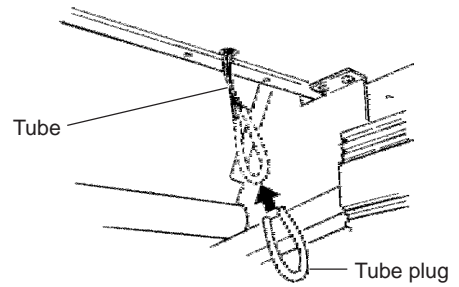

14 Referring to "Unpacking and Repacking" on the packing carton, secure the carriage in place and pack the unit in the carton.

MEMO

User's Reference

Environment Matching

Printing length in the direction of carriage movement may be affected by changes in the operating environment (temperature and humidity). This may result in misalignment of the printing or cutting location in the carriage-movement direction. If this happens, then follow the steps below to perform automatic adjustment and optimize it to the operating environment.

- 1** Press the [MENU] key and [▼] key to make the following screen appear on the display.

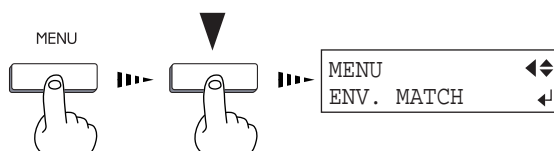

- 2** Press the [ENTER] key. When material is loaded, the message shown in the figure appears. Remove the material, then press the [ENTER] key again.

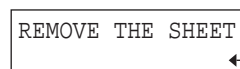

- 3** The printing carriage moves and the printing length in the carriage-movement direction is adjusted.

While automatic adjustment is in progress, the following message appears on the display.

NOW PROCESSING...

- 4** When automatic adjustment ends, the screen returns to the display in step 1.

Performing Cutting or Printing at the Desired Location

Set the print or cutting start position (base point) to the desired location.

1 Load material and install a blade, then press the [SETUP] key.

2 Use the arrow keys to align the blade with the new printing or cutting start location (base point).

Align with the center of the blade installed on the cutting carriage.

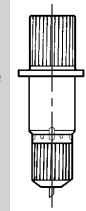

3 Press the [BASE POINT] key.

The BASE POINT LED lights up

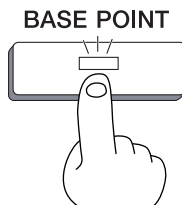

When an align point has been set, it is released if the [BASE POINT] key is pressed.

To release the starting location that has been set...

- Set a new starting location in a different location.
- Press the [SETUP] key to cancel the setup for the material (making the SETUP LED go out).

Adjusting the Printing and Cutting Positions

When printing is followed by cutting, the cutting line may be displaced from the printing. If this happens, use the display menu's [PRINT-CUT ADJ.] function to align the printing and cutting positions.

Read the correction value from the test pattern printed and cut on the material. Enter the read correction value with the operation panel, then align the printing and cutting positions.

- 1 Load material and install a blade, then press the [SETUP] key.

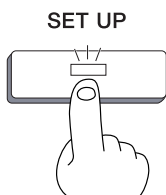

- 2 Press the [MENU] key and [▼] key to make the following screen appear on the display.

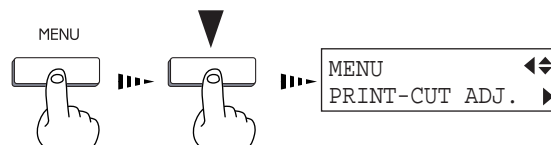

- 3 Press the [▶] key to make the following screen appear on the display.



- 4 Press the [ENTER] key to print and cut the test pattern.

Test pattern

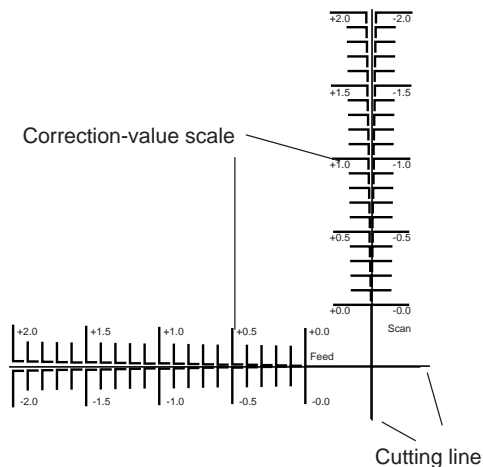

- 5 From the test pattern, read the value at the location shown below.

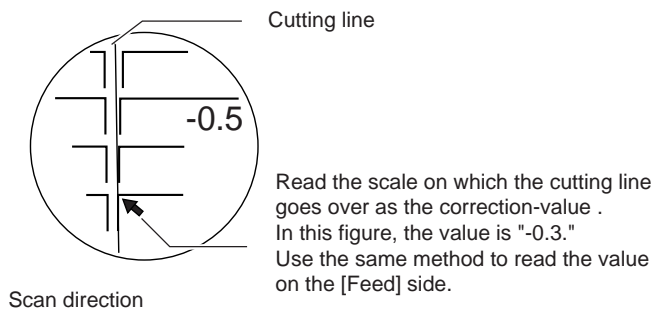

Continued on the next page.

- 6** Use the [▼] key to choose [FEED ADJUST] or [SCAN ADJUST].

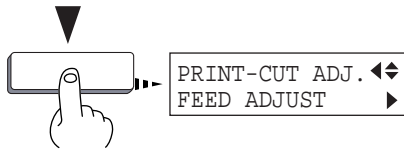

- 7** Press the [▶] key to make the following screen appear on the display.



- 8** Enter the correction value read in step 5.
Select the correction value with the [▲] [▼] key,
and press the [ENTER] key.
Repeat steps 6 through 8 and perform [FEED
ADJUST] or [SCAN ADJUST].

Remove the Printed Material, then Reload the Material and Perform Cutting

This feature is for performing position alignment in cases where printing is performed, after which the material removed from the machine for further processing (such as laminating), then again loaded for cutting.

Printable and Cuttable Size and Position

Crop marks are used to align material that has been removed, but when you are printing with crop marks, the area where you can perform printing and cutting is smaller than the area bounded by the crop marks.

You can easily check the actual size of the area where output is possible without crop marks. While the display shows the area where output is possible, press and hold the [ENTER] key. The actual size where output is possible is displayed until you release the key.

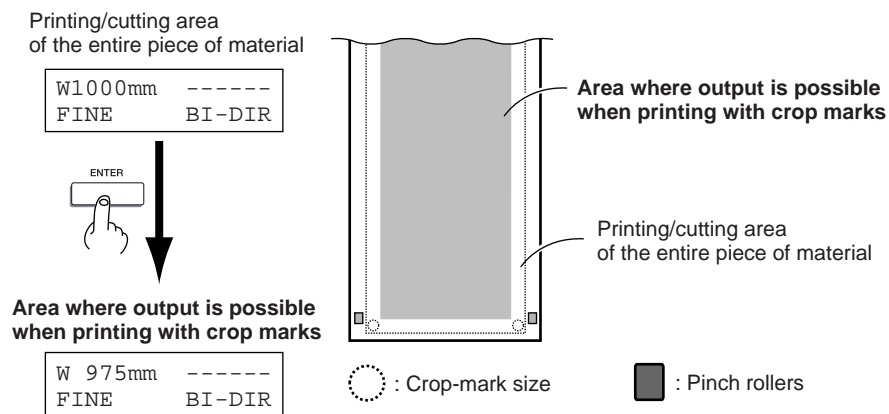

The position where you cut off the material after printing ends is also important. When you reload the material, a margin of 80 mm or more from the rear edge of the crop marks is required. When you are separating the material automatically, set [PAGE MARGIN] to 80 mm or more. (See "Setting the Page Margins" elsewhere in this chapter.)

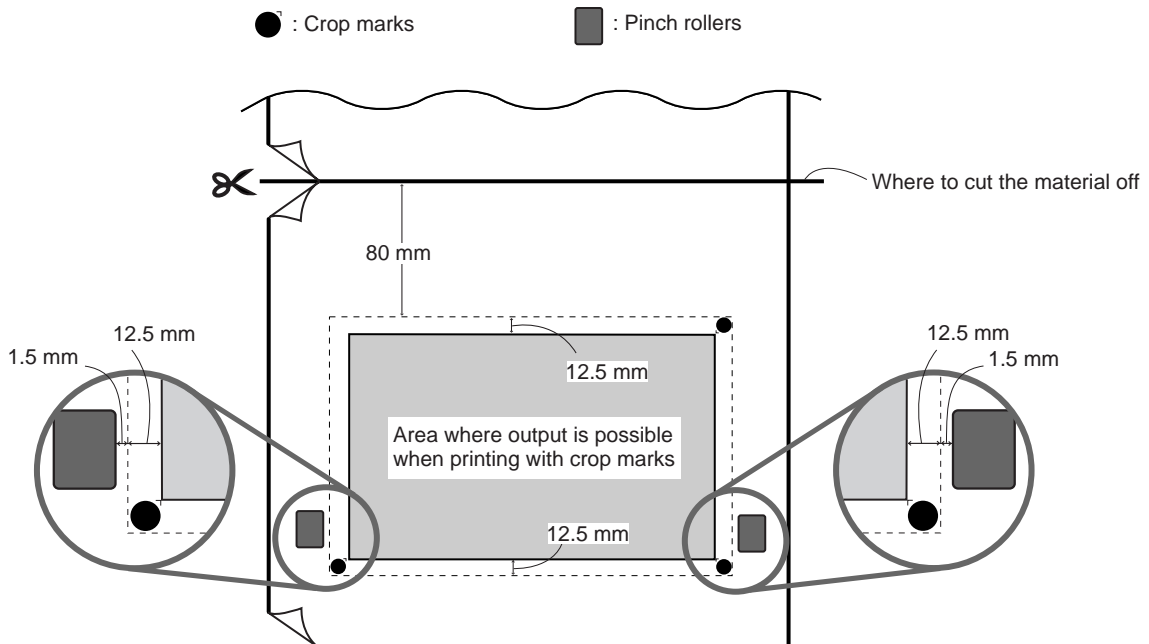



When you are printing with crop marks, then when printing data that exceeds the size where output is possible is received, the following message appears and the system goes into standby.

Stop the output of data from the computer, then press the [SETUP] key to stop printing. Pressing the [ENTER] key starts printing, but the portion that exceeds the size where output is possible is truncated and crop marks are not printed.

CAN'T PRINT CROP
CONTINUE?

Printing with Crop Marks

- 1** Press the [MENU] key and [▼] key to make the following screen appear on the display.

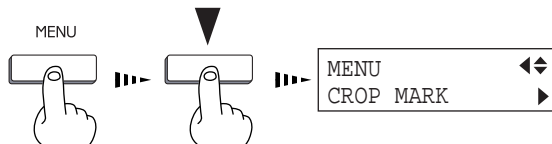

- 2** Press the [▶] key to make the following screen appear on the display.



- 3** Use the [▼] key to select [ENABLE], then press the [ENTER] key.



* Setting [CROP MARK] to [ENABLE] makes the output area 25 mm (1 in.) narrower.

- 4** Send the printing data from the computer. Three crop marks are automatically printed on the left and right areas at the front edge of the material.

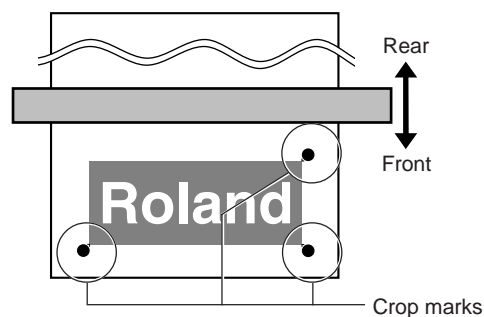

If you used the program to enable or disable crop marks, then crop marks are printed or not printed according to the program settings. The setting made with the control panel for the machine takes effect only in cases where the program does not specify that crop marks are enabled or disabled.

Crop marks are printed bidirectionally. If you have changed the material to a different type or changed the head height, adjust bidirectional printing. For more information about bidirectional printing, see "User's Reference - Make Corrections for Printing."

Reloading and Aligning Material

- 1 Follow steps 1 to 4 on the previous page to perform printing with crop marks.
- 2 When printing is finished press the [SET UP] key, remove the material and carry out lamination (or whatever further processing needs to be done).
Load the material at the same pinch-roller positions used during printing, then press the [SETUP] key. At this time, load the material so that the crop marks are to the inner sides of the pinch rollers on either side.

3 Install a blade holder on the cutting carriage.

4 Set the base point.
Use the arrow keys to align the center of the blade at the location on the crop mark shown in the figure, then press the [BASE POINT] key.

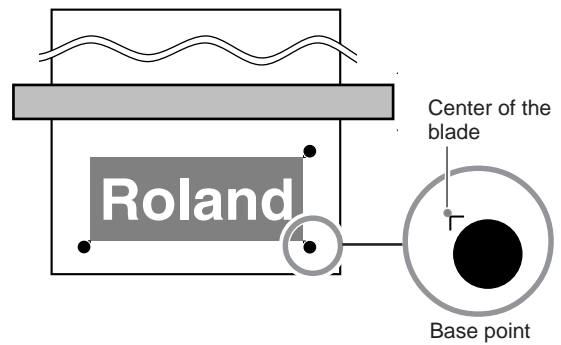

5 Set the align point. Use the arrow keys to line up the center of the tool with one of the crop marks, then press the [ALIGN POINT] key. You normally use the upper right crop mark for this. Line up the center of the tool with the L-shaped mark as shown in the figure. When you are printing something that is much wider than its length and there is only a short distance between the base point and the align point, it may be a good idea to set the align point at the lower left crop mark.

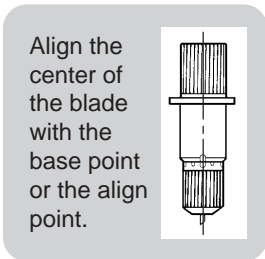
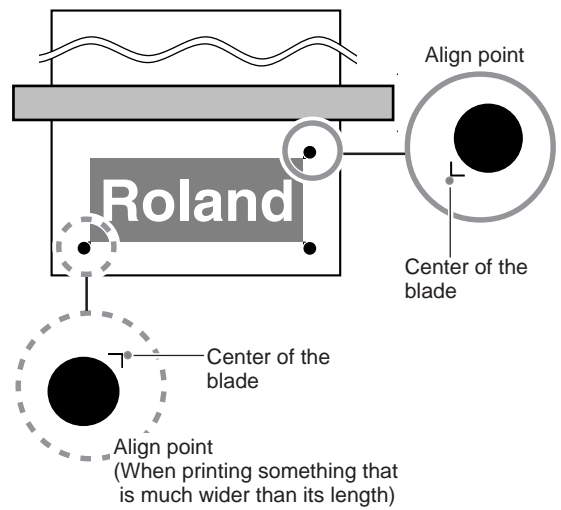

* The align point cannot be set to both the lower left and upper right points.

6 Send the cutting data from the computer.



You cannot set an align point when a line connecting the left and right crop marks is slanted by 5 degrees or more or when the left and right crop marks are misaligned front to back by 20 mm or more. Adjust the loaded position of the material.

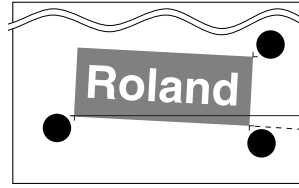

Within 5 degrees, or within 20 mm (13/16 in.) in the sheet-feed direction

Crop marks and the like drawn with computer programs cannot be used as crop marks.

When you have set the align point at the upper right crop mark, correction for length is performed automatically without using the offset value set with [CUTTING ADJ.]. For more information about [CUTTING ADJ.], refer to "Aligning the Printing Length and Cutting Length" elsewhere in this chapter.

Making Corrections for Printing

Feed Correction

This corrects for errors in the amount of feed of the grit rollers due the type of material. Be sure to make this setting when you have replaced the material with a different type. Correcting the amount of feed improves the dot-positioning accuracy in the feed direction, which can help enhance image quality.



When performing test printing for feed correction, load the material correctly (see "Setup for Printing -- Loading the Material"). If the material is not loaded correctly, an accurate test pattern may not be output.

When you use the program to set a correction value for the amount of feed, the program's setting takes priority. The setting made with the control panel for the machine takes effect only in cases where the program does not perform correction of the amount of feed.

1 Press the [MENU] key and [▼] key to make the following screen appear on the display.

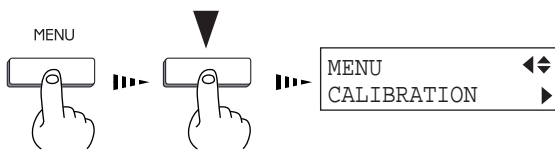

2 Press the [▶] key to make the following screen appear on the display.



3 Press the [▶] key to make the following screen appear on the display.

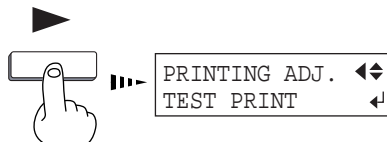

5 Check the test pattern and choose a value with no displacement.

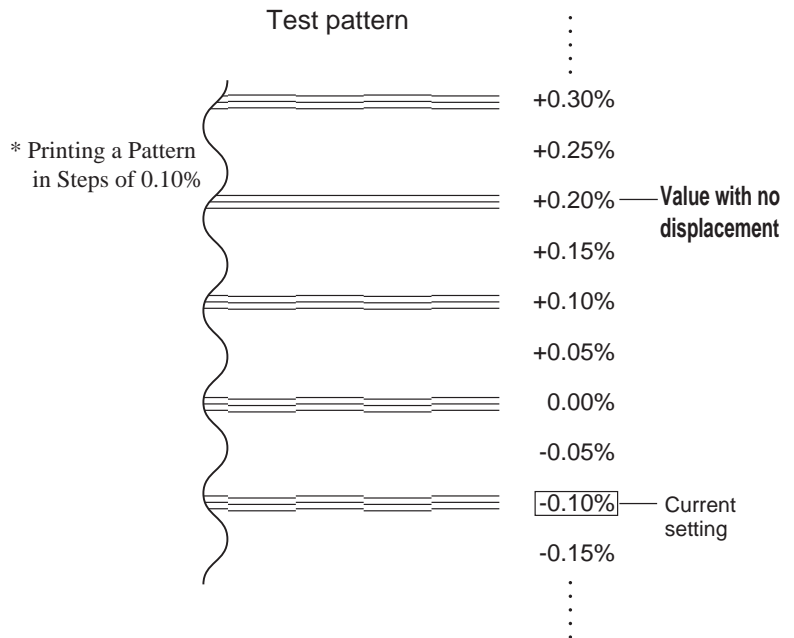

6 Press the [▼] key to make the following screen appear on the display.

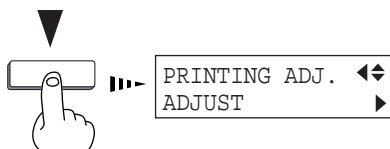

7 Press the [▶] key to make the following screen appear on the display.

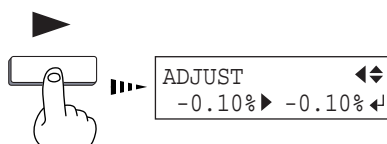

8 Use the [▲] and [▼] keys to set the value you checked in step 4, then press the [ENTER] key.

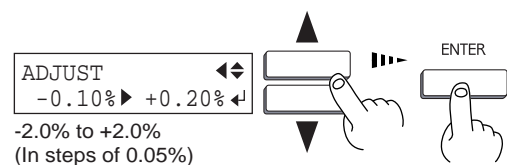

* Test printing prints the pattern in steps of 0.10%.

Bidirectional Correction

* Only when the printing direction at the [PRINT MODE] menu has been set to [BI-DIRECTION] (bidirectional)

This adjusts slippage when performing bidirectional printing.

Make this adjustment when you have replaced the material with a different type or adjusted the head height.

- 1** Press the [MENU] key and [▼] key to make the following screen appear on the display.

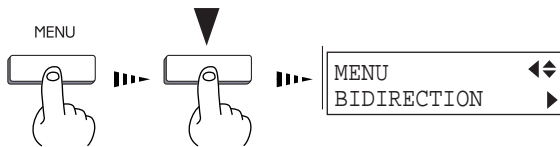

- 2** Press the [▶] key to make the following screen appear on the display.



- 3** Press the [ENTER] key to start printing a test pattern.

- 4** Check the test pattern and choose a value with no displacement.

Test pattern

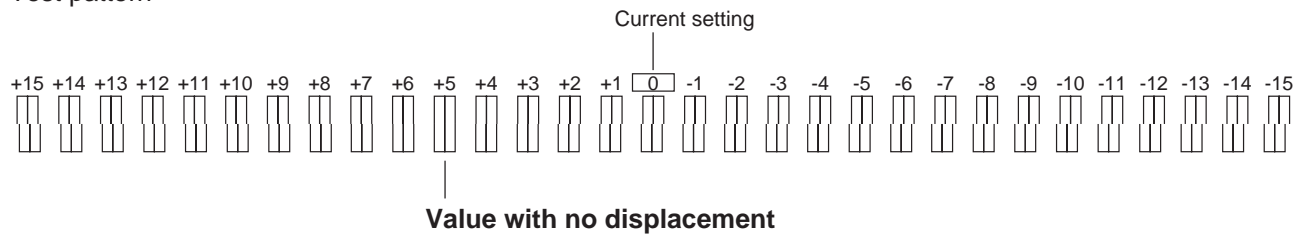

- 5** Press the [▼] key to make the following screen appear on the display.

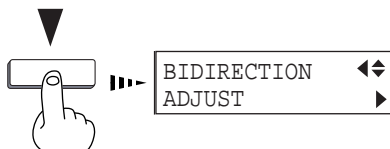

- 6** Press the [▶] key to make the following screen appear on the display.

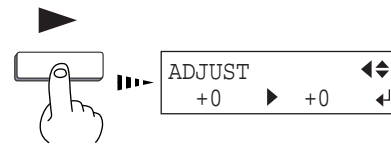

- 7** Use the [▲] and [▼] keys to set the value you checked in step 4, then press the [ENTER] key.

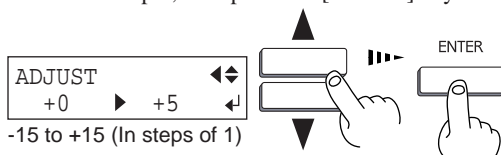

Aligning the Printing Length and Cutting Length

There is normally no need to adjust this. When there is no effect due to expansion or contraction of the material, use with the calibration value always set at "0."

However, when printing is followed by cutting, the cutting length may be displaced from the printing length.

This is because the material may absorb moisture from the ink or the air, making it expand or contract. The degree of expansion or contraction varies depending on the composition of the material, the composition of the base paper, and the temperature and humidity where installed. In general, highly absorbent materials are more susceptible to expansion and contraction.

At such times, use the display menu's [CALIBRATION_CUTTING ADJ.] function to adjust the cutting length with respect to the printing length.

The calibration value that you set persists even after the power is switched off. After performing output, return the calibration value to "0."

When you have set a base point, and have set an align point on the upper-right crop mark, the machine automatically adjusts the length for printing and cutting. At this time, the correction value in this section is ignored. For more information, take a look at "User's Reference - Removing Printed Material, Then Reloading and Cutting."

1 To calculate the correction value, measure the lengths of A, B, C and D in the following diagram.

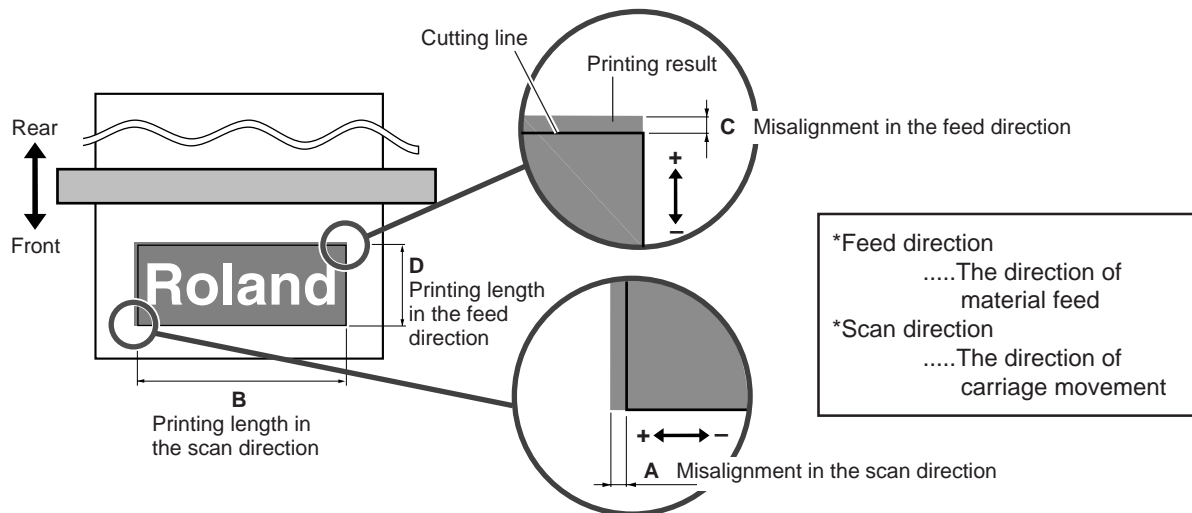

2 Calculate the percentage of cutting-length displacement relative to the printing length.

$$\text{Correction value in FEED direction.} = \frac{\text{C}}{\text{D}} \times 100$$

Offset of FEED-direction data.

$$\text{Correction value in SCAN direction.} = \frac{\text{A}}{\text{B}} \times 100$$

Offset of SCAN-direction data.

* If the cutting line is in the "+" direction from the printing position, then input the correction as a "-".
If the cutting line is in the "-" direction from the printing position, then input the correction as a "+".

3 Press the [MENU] key and [▼] key to make the following screen appear on the display.

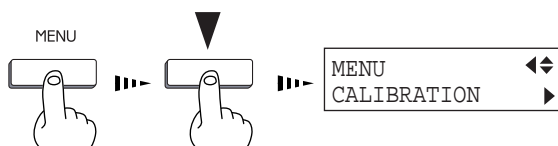

4 Press the [▶] key and [▼] key to make the following screen appear on the display.

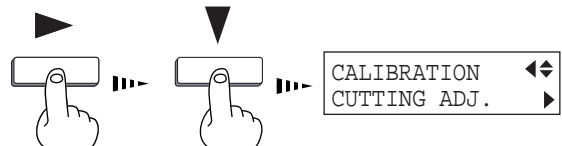

Continued on the next page

5 Press the [▶] key to make the following screen appear on the display.

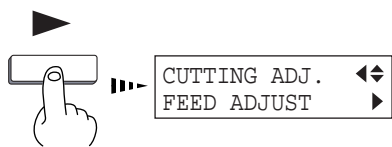

6 Use the [▼] key to choose [FEED ADJUST] or [SCAN ADJUST].



7 Press the [▶] key to make the following screen appear on the display.

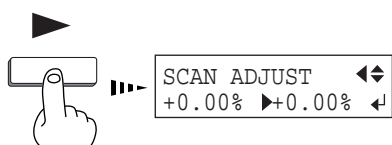

8 Input the correction value calculated in step (2). Select the correction value with the [▲] [▼] key, and press the [ENTER] key. Repeat steps 6 through 8 and perform [FEED ADJUST] or [SCAN ADJUST].

Performing Overprinting

This prints the same image superimposed over the same location a number of times. When printing materials such as fabric, colors may not come out well with just a single printing pass. Overprinting can achieve darker printing results. You can choose either [2] (two passes) or [3] (three passes) as the number of passes for overprinting. Performing overprinting may result in ink smudges or stretch the fabric.



When you use the program to set the number of passes for overprinting, the program's setting takes priority. The setting made with the control panel for the machine takes effect only in cases where the setting for the number of overprinting passes is not made with the program.

1 Press the [MENU] key and [▼] key to make the following screen appear on the display.

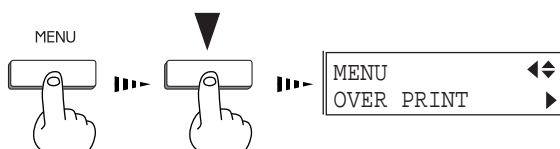

2 Press the [▶] key to make the following screen appear on the display.



3 Use the [▲] and [▼] keys to choose the number of passes (two or three), then press the [ENTER] key.

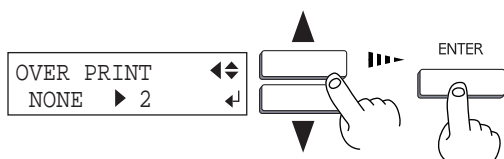

Setting the Page Margins

This makes the setting for the margin between pages.
 When outputting a number of pages continuously, you can establish a margin between the pages.
 You can set this in a range of 0 mm to 100 mm (in 10 mm steps).
 This is set at 20 mm when shipped from the factory.

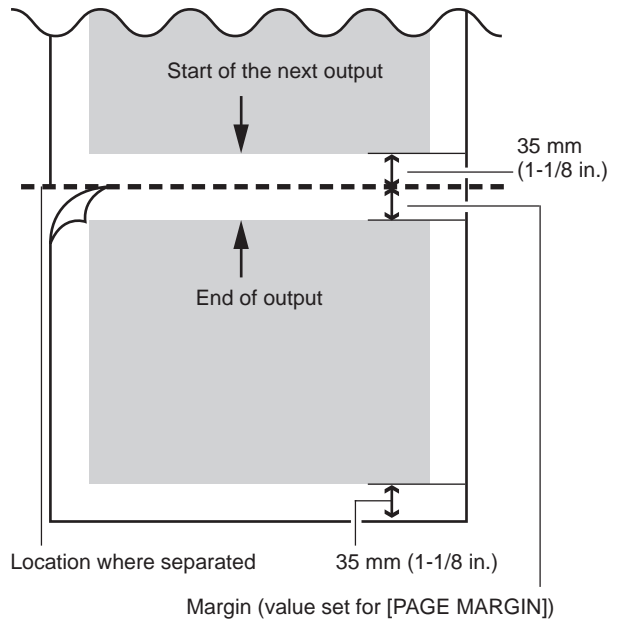
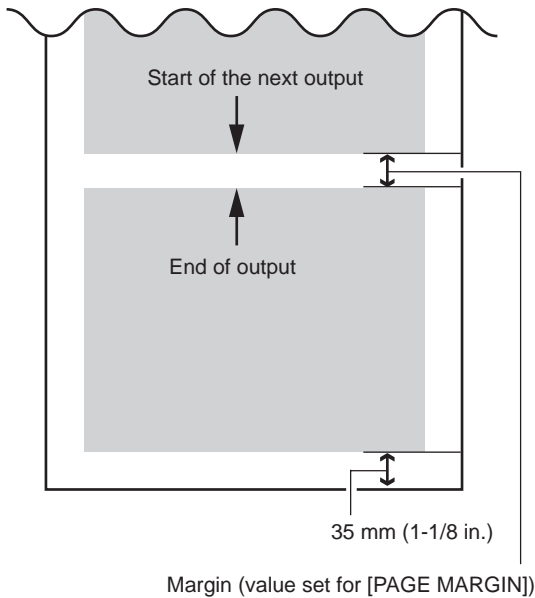

[When the material is not cut off]

[When the material-cutting command is enabled]

- 1 Press the [MENU] key and [▼] key to make the following screen appear on the display.

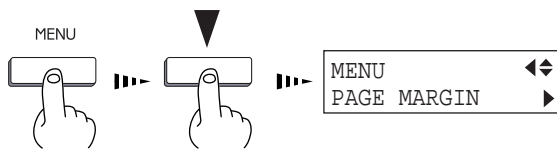

- 2 Press the [▶] key to make the following screen appear on the display.

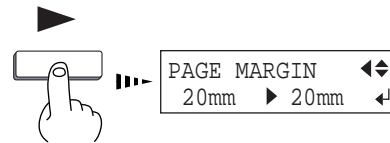

- 3 Use the [▲] and [▼] keys to set a margin, then press the [ENTER] key.

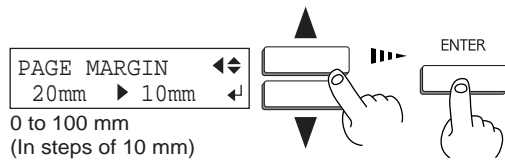

When separating the material with the margin set at [0], the position where the material is separated and the end of printing/cutting may not match.

When performing continuous printing with the margin set at [0], image quality just after starting to print may be poor on the second page or after. Also, dot drop-out or overlap may occur at the page borders.

When you use the program to set the page margins, the program's settings take priority. The setting made with the control panel for the machine takes effect only in cases where the settings for page margins are not made with the program.

About the Prefeed ([PREFEED]) Function

When using roll material, you can check in advance whether there is enough material available for the amount of printing or cutting data, or whether the material can be gripped correctly.

When data is sent from the computer, the amount of material equal to the length of the data is automatically pulled out, and then printing or cutting begins. If material equal to the amount of data is not available, operation pauses and the following message appears on the display.

SHEET TOO SHORT
CONTINUE? ↵

Press the [ENTER] key to perform printing or cutting.

To cancel output, stop sending data from the computer, then hold down the [SETUP] key for 2 to 3 seconds.

When shipped from the factory, the prefeed ([PREFEED]) function is set to [ENABLE] as the default.



When using an optionally available media take-up unit, set the prefeed ([PREFEED]) function to [DISABLE].

To Perform Long Printing/Cutting

When performing printing or cutting over a length of 1.5 m (60 in.) or more, first feed out the required length of material. Then follow the steps below to load the material.

- 1 Pull out the material from the roll and pass it through the unit.

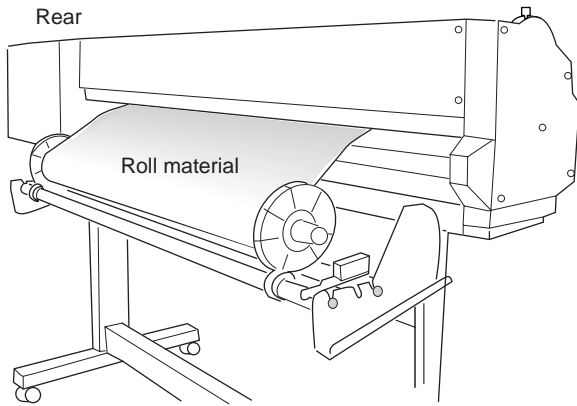

*Use material that is wider by 50 mm (2 in.) or more than the width of the printing or cutting to be performed.

- 2 Position the left- and right-hand pinch rollers at the locations shown in the figure.

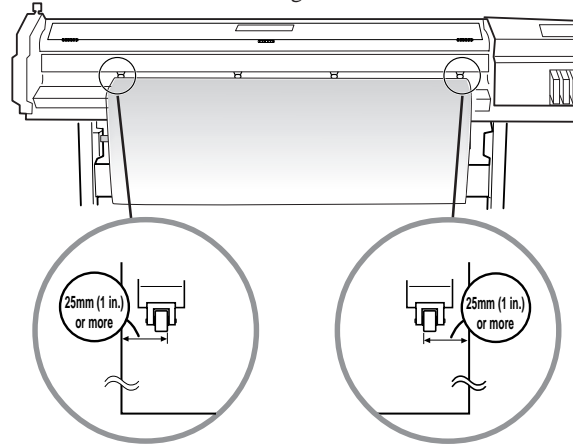

*Make sure the pinch rollers are positioned above the grit rollers.

- 3 Move the sheet loading lever all the way to "LOAD," then close the front cover.

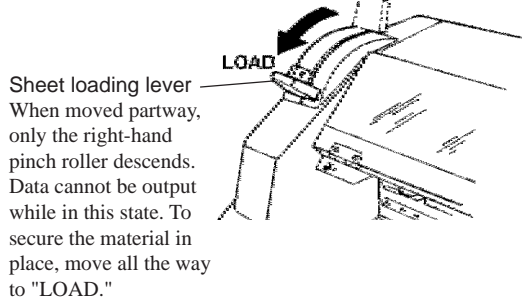

- 4 At [SELECT SHEET], choose [ROLL] or [EDGE], then press the [SETUP] key.

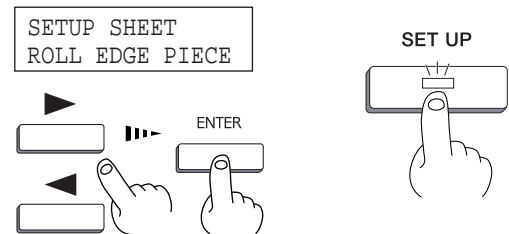

- 5 Press the [MENU] key and [▼] key to make the following screen appear on the display.

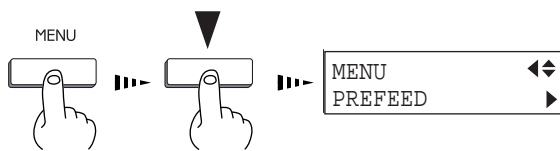

- 6 Press the [▶] key to make the following screen appear on the display.



- 7 Use the [▼] key to select [ENABLE], then press the [ENTER] key.

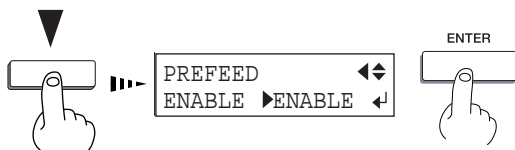

- 8 Send the printing/cutting data from the computer.



When using the [PREFEED] function, set [EDGE SENSE] to [ENABLE].
Depending on the program, the [PREFEED] function may not work.

Adjusting the Height of the Printing Head

When using material that is thick or susceptible to warping, material feed may not proceed smoothly, or the material may jam. When such material is loaded, you can adjust the height of the printing head. You can adjust the head height by moving the lever in the figure any of the positions from 1 to 3, where it clicks into place.

This should normally be left at position 1. If printing results in jamming of the material, the material catching on a printing head, or other problems that indicate that material feed cannot be accomplished smoothly, then position the lever at 2 or 3.

When the height of the printing head has been adjusted, it is necessary to perform bidirectional correction (only when the printing direction for [PRINT MODE] has been set to [BI-DIRECTION]). For more information about bidirectional correction, see "Making Corrections for Printing - Bidirectional Correction."

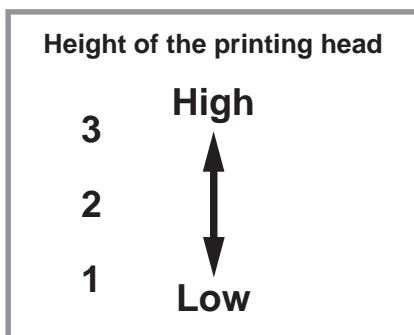

* Be sure that the carriage is in standby position before attempting to move the lever.

Materials

Conditions for Usable Materials

- A) Cuttable material thickness : 0.08 to 0.22 mm (0.00315 in. to 0.00866 in.) (depending on material composition)
- B) Maximum material thickness, including base paper (peeled-off paper)
 - : Printing only 1.0 mm (0.039 in.)
 - : When performing cutting 0.4 mm (0.0157 in.)
- C) Maximum diameter for roll material : 180 mm (7-1/16 in.) (surface to be printed or cut must face outward)
- D) Core inner diameter for roll material : 50.8 or 76.2 mm (2 in. or 3 in.)
- E) Maximum weight for roll material : 20 kg (44.1 lb.)
- F) Roll material with a starting edge that is not taped down

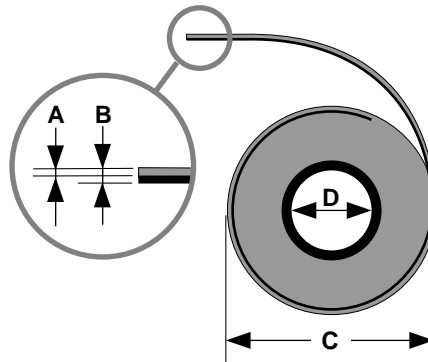

Side view of roll material



Acceptable material widths

131 to 1371 mm (5-3/16 to 54 in.)

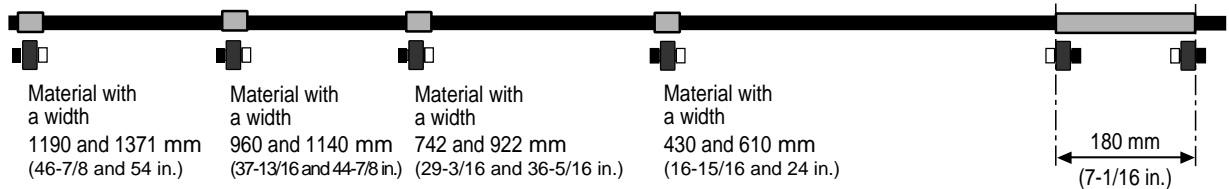
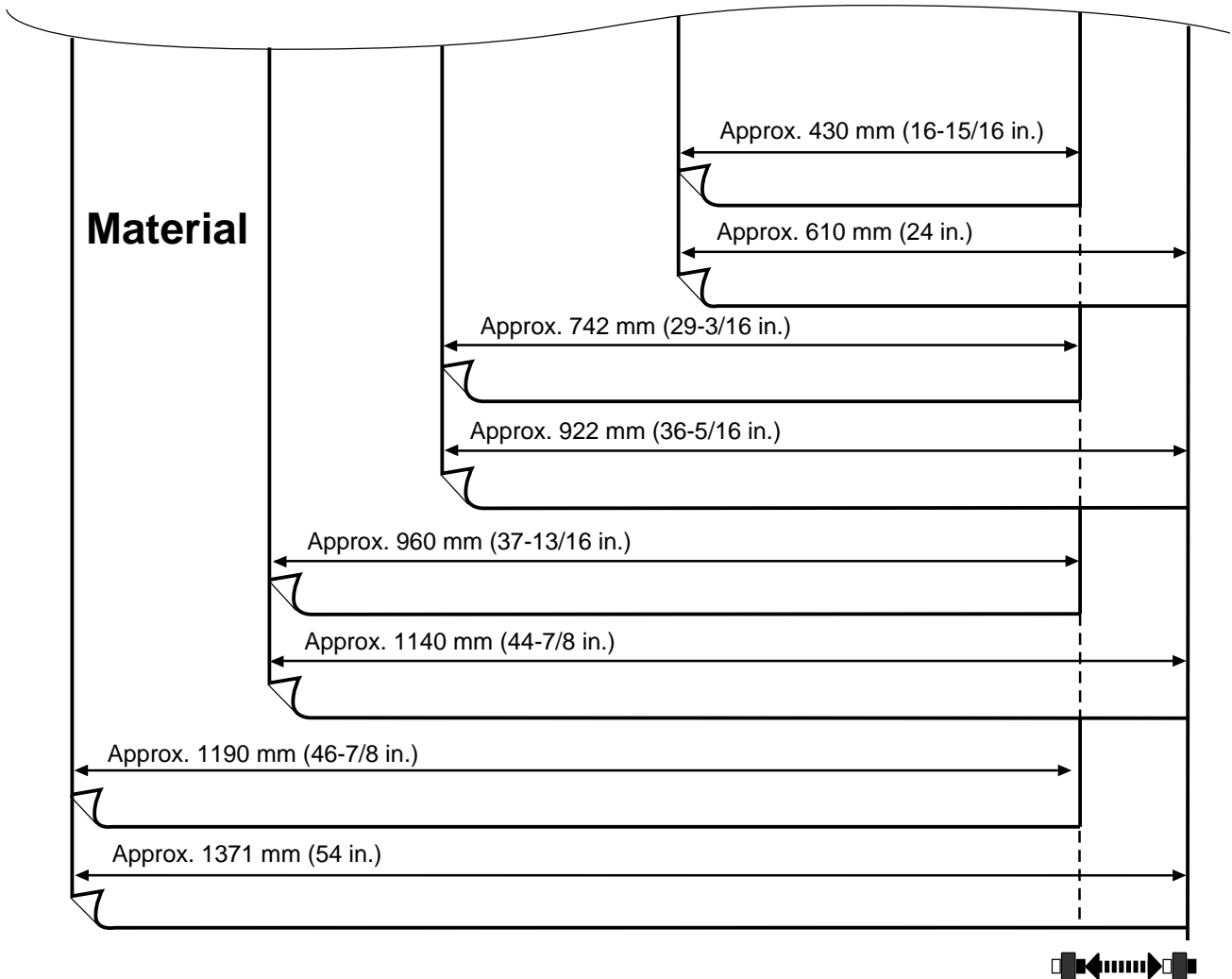
* However, when loading material with a width of 131 to 430 mm (5-3/16 to 17 in.), set the [EDGE SENSE] menu item to [DISABLE].



* Set the middle pinch rollers at any of these as required.

-  : Grit roller
-  : Pinch roller (middle)
-  : Pinch roller (left)
-  : Pinch roller (right)

Make sure the left and right pinch rollers are positioned above the grit rollers.

About Blade Life

Cutting conditions and blade life vary according to the hardness of the material and the usage environment. Making the settings for the conditions described below does not automatically guarantee attractive cutting results in all situations. Before performing actual cutting, be sure to carry out a cutting test and make any necessary adjustments (see "Setup for Cutting -- Test Cutting").

If the material is not cut through completely even when the tool force is increased by 50 to 60 gf more than the tool force values shown below, it means that the useful life of the blade has ended. Replace with a new blade.

Blade	Material	Tool-force	Amount of cutter offset	Life of a blade (General guide)
ZEC-U1005	General Signage Vinyl	50 to 150 gf	0.25 mm (0.01 in.)	8000 m
ZEC-U5025	General Signage Vinyl	30 to 100 gf	0.25 mm (0.01 in.)	4000 m
	Fluorescent Vinyl	120 to 200 gf	0.25 mm (0.01 in.)	4000 m
	Reflective Vinyl	100 to 200 gf	0.25 mm (0.01 in.)	4000 m

* The values for life-span are intended to serve as a general guide when cutting materials of identical type.

About the Printing/Cutting Area

The printing/cutting area along the horizontal plane (the direction in which the carriage moves) is determined by the position of the pinch rollers. The workable area spans the length between the two rollers, minus a margin of about 1.5 mm (about 0.06 in.) on both sides. If [PIECE] has been selected and material length (the distance in the X direction as shown in the figure) is 2,000 mm, the area is the same as when [EDGE] has been chosen.

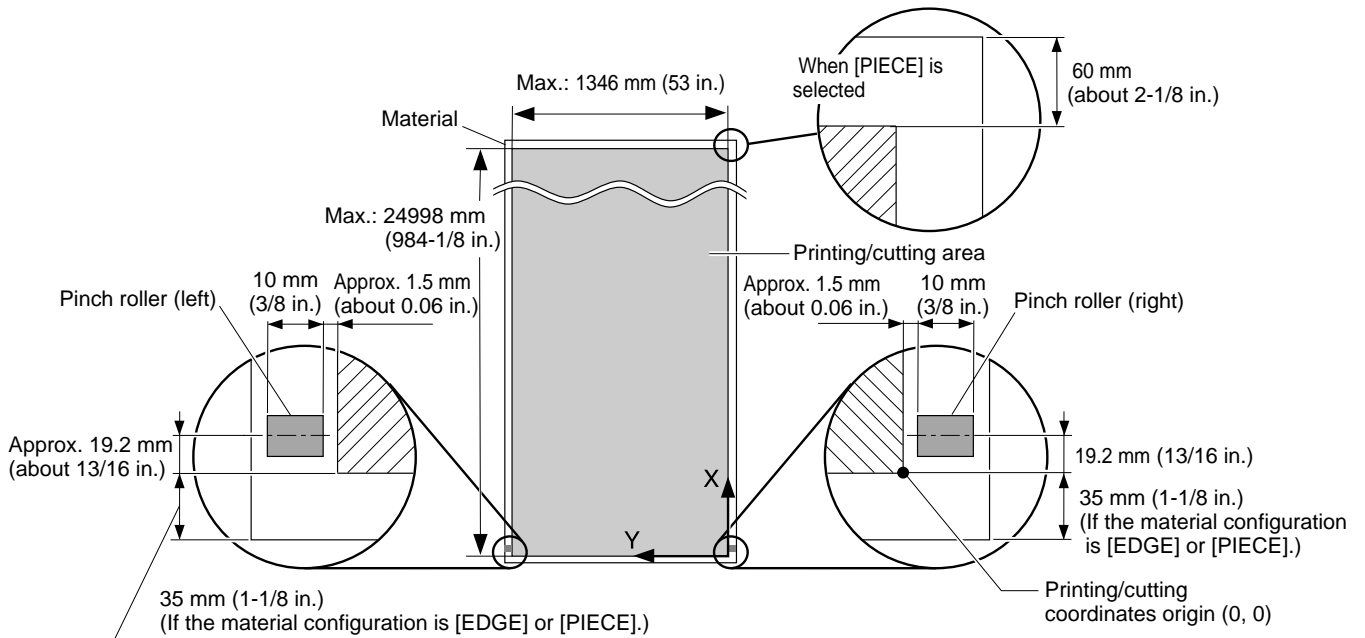





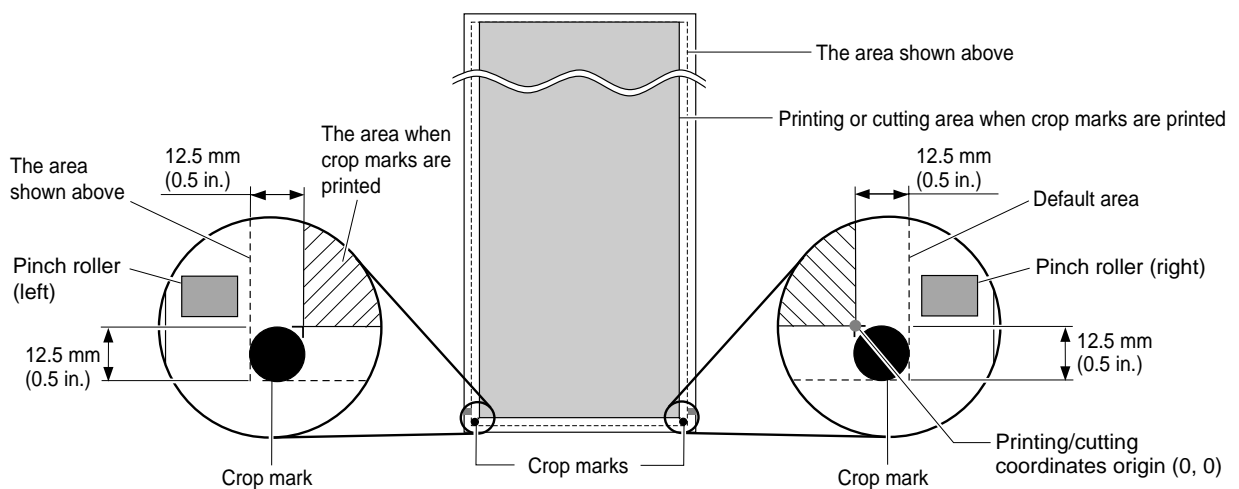

* The arrows in the figure indicating the X and Y directions indicate respectively the positive directions of the X axis and Y axis.

When crop marks are printed, the printing or cutting area in the area shown above is reduced by an amount equal to the size of the crop marks (12.5 mm (0.5 in.) + 12.5 mm (0.5 in.)).











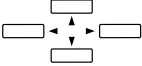

MEMO

Description of Keys

Key	Top menu	Submenu	Function	Setting range	Default value
	—	—	This switches on and off the sub power . When the power is switched on, the POWER LED lights up.	—	—
	—	—	This detects the presence of material, and its dimensions, and shows the printable or cuttable size on the display. The SETUP LED flashes while detection of material width is in progress. When setup finishes, the SETUP LED lights up continuously. Also press this key when removing the material.	—	—
	—	—	The [PAUSE] key pauses operation. The PAUSE LED lights up while paused. Pressing this key again cancels the paused state. Holding down the [SETUP] key for about 1 second while paused causes remaining data to be cleared and cancels the material's setup state.	—	—
	—	—	This sets the present blade position (blade center) at the printing or cutting start location (base point). For more information, see "User's Reference -- Performing Cutting or Printing at the Desired Location."	—	—
	—	—	This sets an align point for correction when the material is not straight. The angle of the material, referenced from the base point, is stored in memory. Any angle of 5° or less may be set. This setting is valid only when cutting.	—	—
	PRINT MODE	—	This displays the [PRINT MODE] menu for setting image quality. This is used to specify the printing quality and unidirectional or bidirectional printing. Settings cannot be made while printing is in progress. To exit the [PRINT MODE] menu screen, press the [MENU] key or the [CLEANING] key or the [SETUP] key. For more information, see "Setup for Printing -- Setting the Printing quality and Printing direction."	[PRINT MODE] PHOTO SUPER FINE FINE2 NORMAL FAST DRAFT [PRINT DIRECTION] UNI-DIRECTION BI-DIRECTION	[PRINT MODE] FINE2 [PRINT DIRECTION] BI-DIRECTION
	FORCE	—	This enters the menu for setting the conditions for cutting. You can set the values for blade force, cutting speed, blade offset compensation, and tool movement speed when raising the tool. For more information, see "Display Menus Flowchart." * When [COMMAND] on the display menu has been set to [ENABLE], the program's settings for the cutting conditions take priority. To give priority to the cutting conditions set on the machine, turn off the program settings, or set the [COMMAND] menu to [DISABLE]. For more information about the [COMMAND] menu, see the section "Descriptions of Menu Items - Description of Menus."	[FORCE] 30 to 200 gf (In steps of 5 gf) [SPEED] 1 to 60 cm/s (In steps of 1 cm/s) [OFFSET] 0 to 1.5 mm (In steps of 0.025 mm) [UP-SPEED] 1 to 60 cm/s (In steps of 1 cm/s)	[FORCE] 50 gf [SPEED] 40 cm/s [OFFSET] 0.25 mm [UP-SPEED] 60 cm/s

Description of Keys

Key	Top menu	Submenu	Function	Setting range	Default value
SHEET CUT 	—	—	This cuts off the material at the present location of the blade tip. Press this to cut off the portion already printed or cut from the roll. You cannot sever a piece of material while printing or cutting is in progress. For more information, see "Remove the Material."	—	—
MENU 	—	—	This enters the menu mode. When a menu is displayed, the [▲] and [▼] keys move to the next menu, the [▶] moves to a submenu, and the [◀] key moves to the previous screen.	—	—
ENTER 	—	—	This is used to accept, execute, or save the item shown on the display.	—	—
	—	—	These move the material and the carriage. When a menu is displayed, these move among the menu items.	—	—
TEST PRINT 	—	—	Holding down this key for 1 second or longer performs a printing test in an area of approximately 108 mm x 18 mm (4.25 in. x 0.71 in.). Before starting to print, you can carry out a test printing to check the printing quality. For more information, see "Setup for Printing -- Test Printing." If there is a problem with the state of the heads, such as dot drop-out, perform head cleaning.	—	—
CLEANING 	—	—	Holding down this key for 1 second or longer performs cleaning for the printing heads. You can perform cleaning while in any state. For more information, see "Maintenance -- Cleaning the Printing Heads."	—	—
TEST CUT 	—	—	Holding down this key for 1 second or longer performs a cutting test in an area of approximately 20 mm x 20 mm (0.79 in. x 0.79 in.). For more information, see "Setup for Cutting -- Test Cutting" If there are problems with the quality of cutting results for the material, press the [CUT CONFIG] key and adjust the cutting conditions.	—	—
TOOL UP/DOWN 	—	—	This forces the tool to move up or down.	—	—
MENU  +  	MENU LANGUAGE	—	This sets the language for screen messages. You can select either English or Japanese.	ENGLISH JAPANESE	ENGLISH

Description of Menu Items

Description of Menus

Pressing the [MENU] key enters the menu mode.

(*) When you use the program to make the setting for the corresponding item, the program's setting takes priority. To give priority to the setting made on the machine, turn off the program's settings.

Top menu	Submenu	Function	Setting range	Default value
DEMO	PRINT & CUT	This performs printing or cutting of sample data. [PRINT & CUT]: This outputs the sample data for printing and cutting. [PRINT]: This outputs the sample data for printing. [CUT]: This outputs the sample data for cutting.	—	—
CALIBRATION	PRINTING ADJ. (*)	This corrects for errors in the amount of feed of the grit rollers due the type of material. Be sure to make this setting when you have replaced the material with a different type. Make this setting again when horizontal stripes are plainly visible on printing results. [TEST PRINT]: This menu is for verifying the adjustment. [ADJUST]: This sets the correction value. For more information, see "User's Reference -- Making Corrections for Printing -- Feed Correction"	[PRINTING ADJ.] -2.0% to +2.0% (In steps of 0.05%)	0%
	CUTTING ADJ.	This corrects the cutting length relative to the print length (distance correction). For more information, see "User's Reference -- Aligning the Printing Length and Cutting Length" [FEED ADJUST]: This sets the adjustment value for the material-feed direction. [SCAN ADJUST]: This sets the adjustment value for the left-right direction (the carriage-movement direction).	[CUTTING ADJ.] -2.0% to +2.0% (In steps of 0.01%)	0%
BIDIRECTION	TEST PRINT ADJUST	This adjusts for slippage when performing bidirectional printing. This must be readjusted when you have replaced the material with a different type or adjusted the head height. [TEST PRINT]: This menu is for verifying the adjustment. [ADJUST]: This sets the correction value. For more information, see "User's Reference -- Making Corrections for Printing -- Bidirectional Correction."	-15 to +15 (In steps of 1)	Correction value when shipped from the factory
OVER PRINT (*)	—	You can carry out the same printing superimposed over the same location. When printing materials such as fabric, colors may not come out well with just a single printing pass. This should normally be set to [NONE]. For more information, see "User's Reference -- Performing Overprinting."	NONE / 2 / 3	NONE
DRYING TIME (*)	—	This sets the drying time for the material. For materials with low absorbency that are difficult to dry, make the setting for a longer time. When printing is followed by cutting, cutting is performed after waiting for the set time.	NONE/ 10 to 990 sec. (In steps of 10 sec.)	NONE
EDGE SENSE	—	This specifies whether detection of the front and rear edges of the material is enabled or disabled. This should normally be set to [ENABLE]. When loading transparent material or material with a width of 131 to 430 mm (5-3/16 to 17 in.), set this to [DISABLE]. When set to [DISABLE], then during material setup only the [ROLL] selection is available. When doing this, ensure a margin of 35 mm (1-7/16 in.) or more from the leading edge of the material to the start position for printing or cutting.	ENABLE / DISABLE	ENABLE
CROP MARK (*)	—	This specifies whether output of crop marks is enabled or disabled. When set to [ENABLE], crop marks are automatically added to the data sent from the computer and printed.	ENABLE / DISABLE	DISABLE

Description of Menu Items

Top menu	Submenu	Function	Setting range	Default value
TIME OUT	—	When a certain amount of time passes with no data sent from the computer, the current output is considered to be finished. "TIME OUT" sets the time used for this determination.	NONE/ 10 to 990 sec. (In steps of 10 sec.)	NONE
ENV.MATCH	—	This performs automatic adjustment to obtain a state optimized to the operating environment (temperature and humidity). For more information, see "User's Reference -- Environment Matching."	—	—
FACTORY DEFAULT	—	This returns all menu settings to their original values when shipped from the factory. For more about the factory defaults for the various settings, see the "Default value" entry for each menu setting in this section.	—	—
PRINT-CUT ADJ.	TEST PRINT FEED ADJUST SCAN ADJUST	[TEST PRINT]: This prints a test pattern for adjustment use. [FEED ADJUST]: This sets the adjustment value for the material-feed direction. [SCAN ADJUST]: This sets the adjustment value for the left-right direction (the carriage-movement direction).	— [FEED ADJUST] [SCAN ADJUST] -2.0 to +2.0 mm (In steps of 0.1 mm)	— 0 mm
INK CONTROL	EMPTY MODE FILL INK PUMP UP HEAD WASH	When replacement of the ink cartridge becomes necessary while printing is in progress, this setting determines whether printing continues or pauses. This setting is used when the ink cartridge cannot be changed immediately during printing, such as during unattended operation at night. [LATER] causes printing to continue without pause even if ink refilling becomes necessary. Printing continues with the small amount of ink remaining, so the printed image may become faint as the ink runs out. In general, it should be possible to perform about 1 m ² (10 ft ²) of printing once this message appears, although the actual varies widely according to the amount of ink needed for the particular image. Printing is continued only for the data currently being printed. Operation stops after one image is output. [PROMPT] causes operation to pause immediately when the ink cartridge needs to be changed. Printing is resumed by replacing the cartridge and pressing the [PAUSE] key. Please note, however, that the colors of an image in progress may no longer be perfectly matched if the unit is allowed to remain paused for two or three hours before resuming printing. [FILL INK]: Refills the printing heads with ink. Normally there is no need to do this, because refilling is automatic. [PUMP UP]: Drains ink from the printing heads. [HEAD WASH]: This washes the printing heads with optionally available cleaning cartridges. For more information, see "Maintenance - When Moving the Unit..."	[EMPTY MODE] LATER/ PROMPT	LATER
SYSTEM REPORT	—	This prints the current status of setting and other system information.	—	—
MENU UNIT	—	This selects millimeters or inches as the unit of measurement for the width displayed on the top menu after setting up the material. When inch display is used, values are displayed to the first digit to the right of the decimal point.	mm / INCH	mm

Top menu	Submenu	Function	Setting range	Default value
PAGE MARGIN (*)	—	This makes the setting for the margin between pages. When outputting a number of pages continuously, you can establish a margin between the pages. For more information, see "User's Reference -- Setting the Page Margins."	0 to 100 mm (In steps of 10 mm)	20 mm
PREFEED	—	This specifies whether the material prefeed function is enabled or disabled. When set to [ENABLE], an amount of material equal to the size of the data sent from the computer is fed out first, and then printing or cutting are performed. When set to [DISABLE], use the arrow keys to feed out the length of material to be used. After feeding it out, return it to its original position and leave it loose behind the unit. If cutting is started without doing this first, a motor error may occur or the material roll may fall when the material is pulled out.	ENABLE/ DISABLE	ENABLE
SLEEP	—	This sets the time that elapses before the unit enters the SLEEP mode. The SLEEP mode is enabled when the system has been inactive for a specified time. (When in the SLEEP mode, the POWER LED flashes once per second.) To release the SLEEP mode... - Touch any key on the control panel. - Send data from the computer. - Open the front cover. - Move the sheet loading lever toward the back of the unit.	NONE/15 min to 120 min (In steps of 15 min)	15 min
COMMAND	VS COMMAND !FS COMMAND	This setting is made cutting conditions set with a program are made to take priority. When set to [DISABLE], cutting is performed using the values set with the machine. [VS COMMAND]: To perform cutting set the speed determined by a VS command (tool speed setting command) sent from the computer, set this to [ENABLED]. [!FS COMMAND]: To perform cutting set the tool force determined by an !FS command (tool force setting command) sent from the computer, set this to [ENABLED].	[VS COMMAND] ENABLE/ DISABLE [!FS COMMAND] ENABLE/ DISABLE	ENABLE
AUTO SHEET CUT	—	This selects whether the material-cutting command is enabled or disabled. When set to [ENABLED], the material is cut automatically when the computer sends a material-cutting command. For more information, see "Remove the Material -- Cut the material from the roll -- When sending a material-cutting command from the computer to separate the material automatically."	ENABLE/ DISABLE	ENABLE
INK LEFT	—	This shows the amount of ink left after each of the ink cartridges has been installed. The fewer the markers ("■"), the less ink is left. * If a partially used ink cartridge is removed and reinstalled, or if a partially used ink cartridge is installed, the cartridge is taken to be unused, and the displayed amount of remaining ink is not true. For more information, see "Maintenance -- Check how much ink remains."	—	—

Description of Menu Items

Top menu	Submenu	Function	Setting range	Default value
HEAD CLEANING		<p>You can use the [TEST PRINT] key to perform a printing test and check the printing quality before starting to print. This also cleans the printing heads if there is a problem in the printing test.</p> <p>Normally cleaning is performed by pressing the [CLEANING] key on the control panel, but if doing so doesn't correct the problem, use this menu to perform cleaning.</p> <p>Because cleaning subjects the head to wear and consumes ink, it should only be performed when absolutely necessary.</p> <p>Performing cleaning from the [POWERFUL] menu in particular subjects the head to early wear and used up large amounts of ink.</p>	—	—
	MEDIUM	<p>[MEDIUM]: This is used when performing cleaning by pressing the [CLEANING] key does not correct the problem. After cleaning, carry out a printing test to make sure there are no problems with printing quality.</p>		
	POWERFUL	<p>[POWERFUL]: Used when performing cleaning with [MEDIUM] several times does not restore the printing quality. After cleaning, carry out a printing test to make sure there are no problems with printing quality.</p> <p>For more information, see "MAINTENANCE -- Cleaning the Printing Heads."</p>		

Display Menu Flowchart

For details about each of the menus, see the "Description of Display Menus."

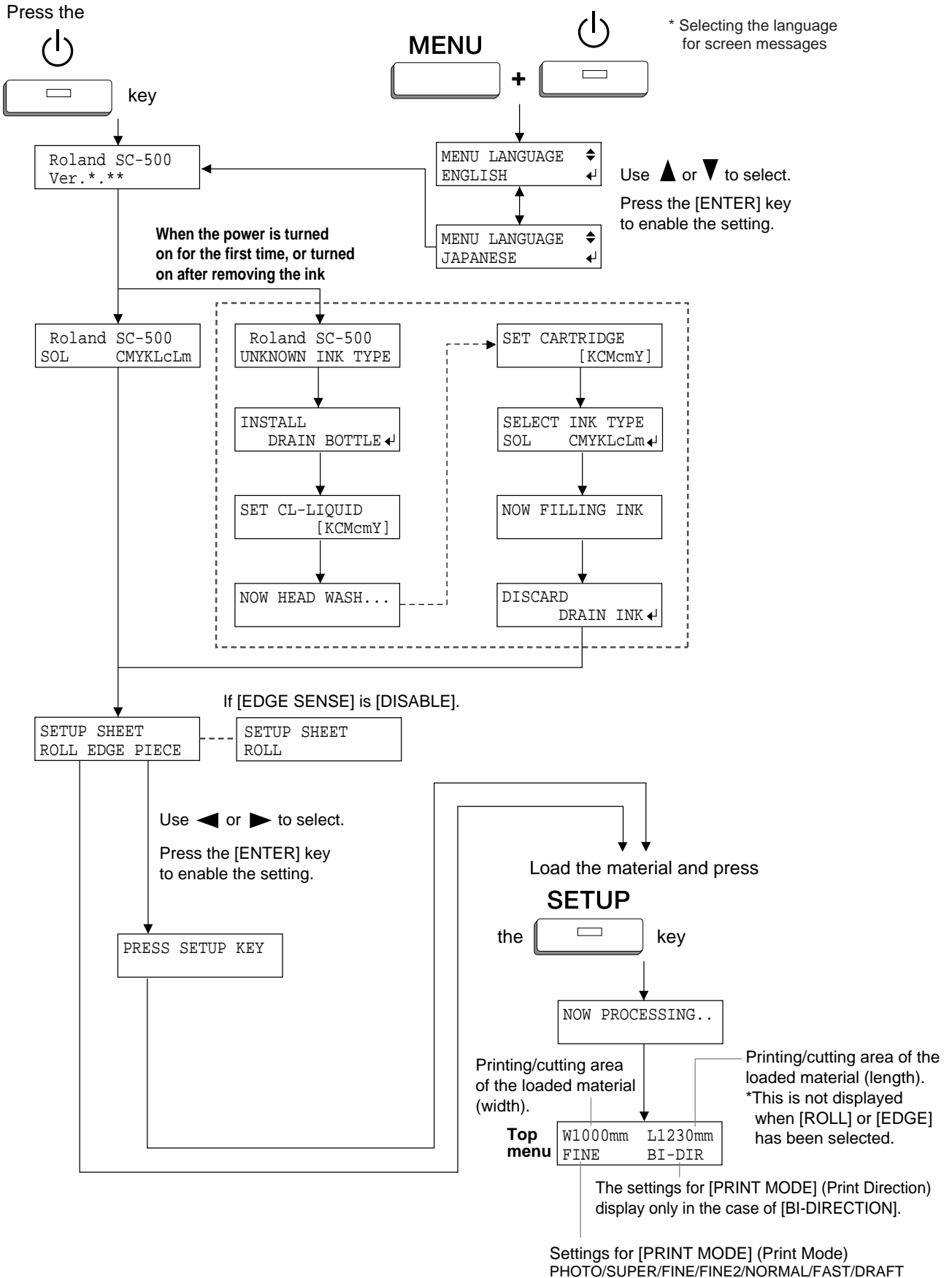

Description of Menu Items

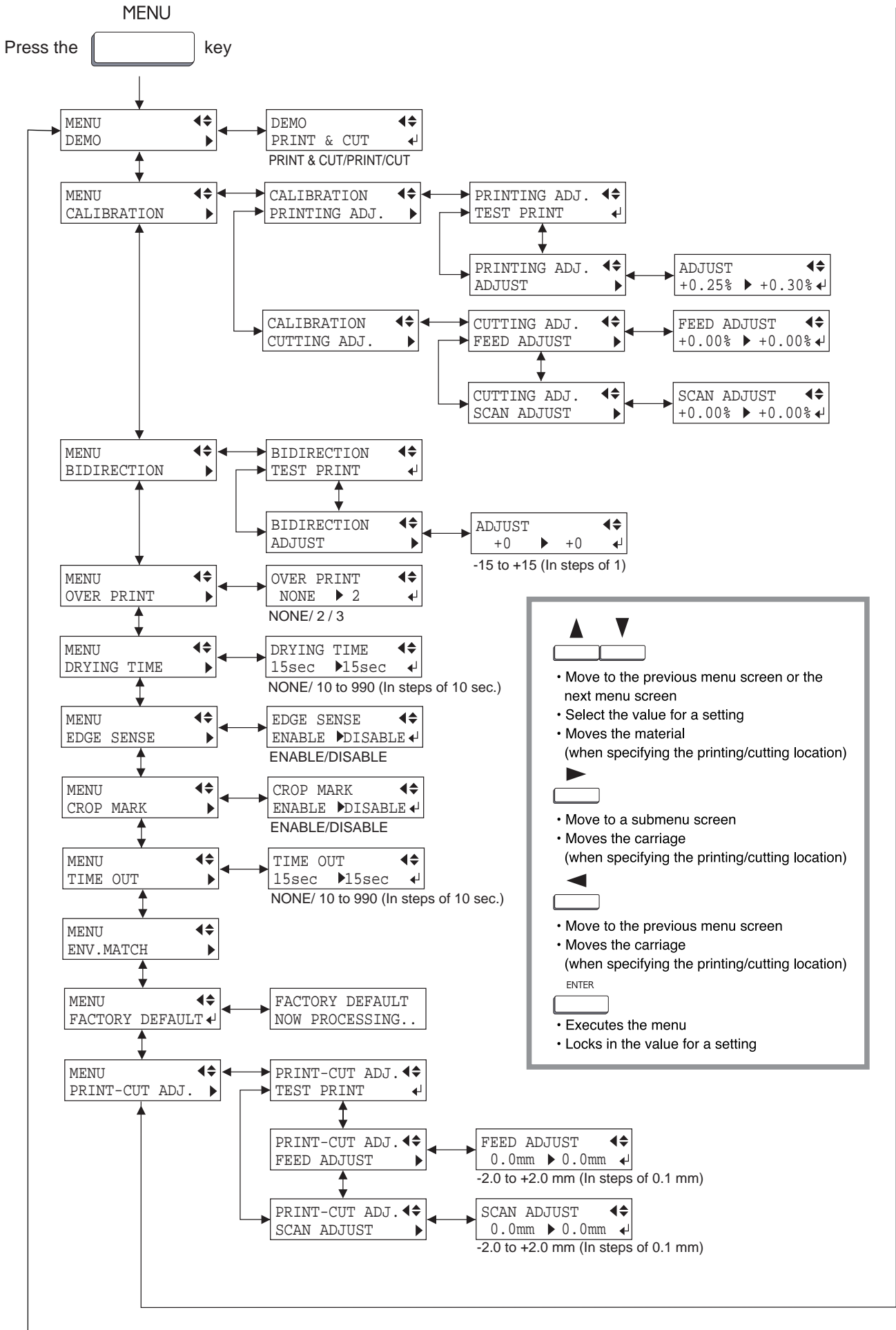

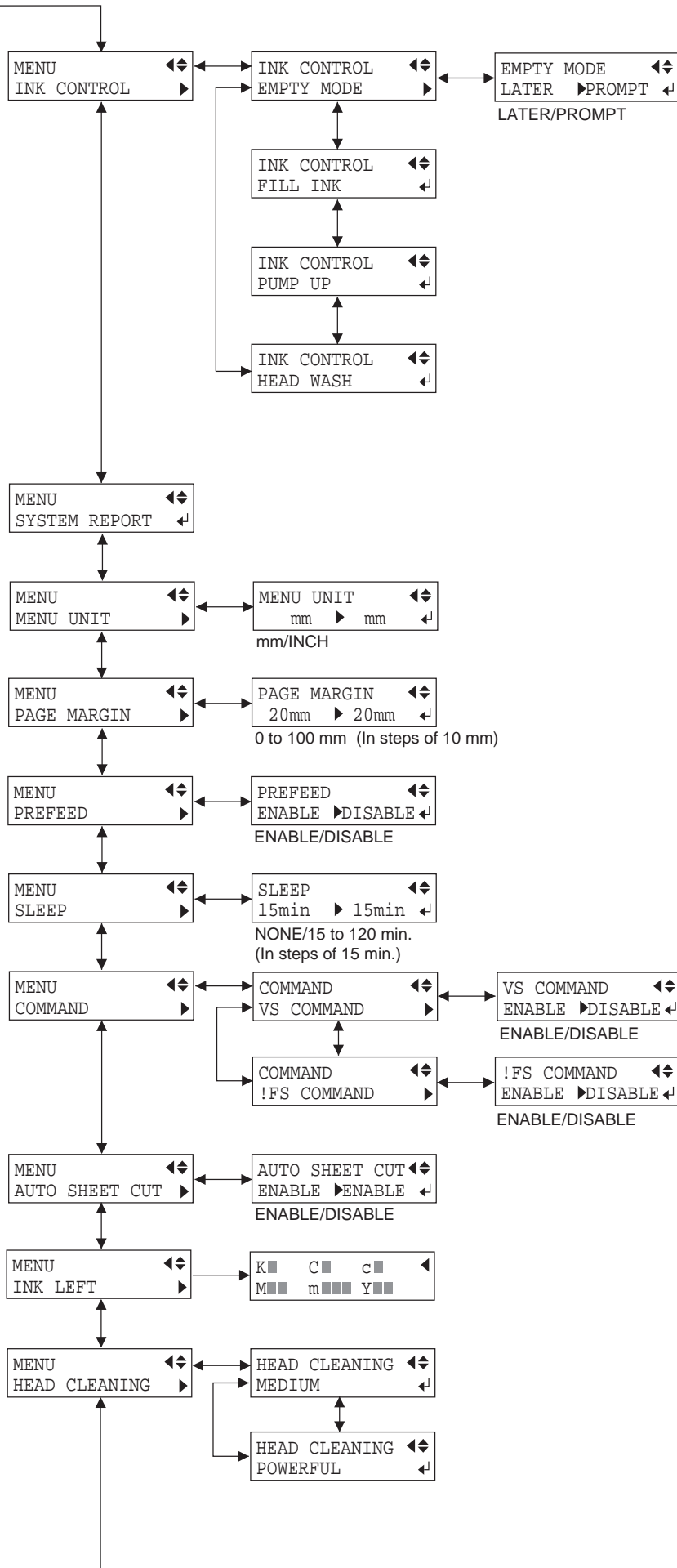

PRINT CONFIG

Press the key

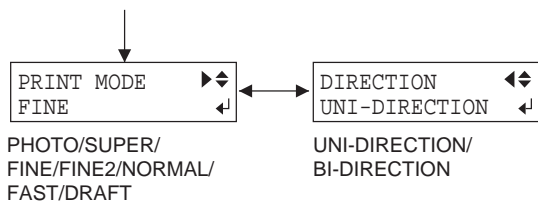

Use ▲ or ▼ to select.
Press the [ENTER] key to enable the setting.

CUT CONFIG

Press the key

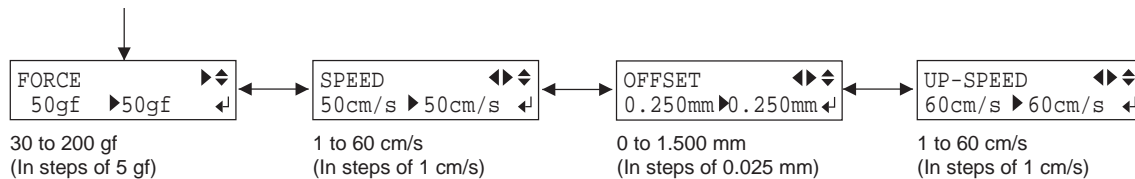

Use ▲ or ▼ to select.
Press the [ENTER] key to enable the setting.

What to Do If...

If the machine doesn't run...

Is the power cord connected correctly?

Connect the power cord to the unit, and plug the other end securely into an electrical outlet. (See “What to Do upon Opening the Carton - 2 Setting Up and Connection” .)

Is the machine power on?

Turn on the power. (See “What to Do upon Opening the Carton -- 5 Powerup” .)

Has material been loaded (the SETUP LED is lighted)?

If the SETUP LED is not illuminated, make sure the material is loaded correctly and press the [SETUP] key to illuminate the SETUP LED.

Is the PAUSE LED lighted?

If the [PAUSE] key has been pressed and the PAUSE LED is lighted, the unit has been paused.

To resume printing or cutting, press the [PAUSE] key again. The PAUSE LED is extinguished, and printing or cutting resumes.

To terminate printing or cutting, first stop the transmission of printing or cutting instructions from the computer. Then press the [SETUP] key. Hold down for about 1 second. This deletes the printing or cutting instructions that have already been sent from the computer, and printing or cutting is stopped.

Is the top menu displayed?

If the top menu isn't displayed, printing doesn't start even when data is sent from the computer.

Top menu

W1234mm	L ---mm
FINE	BI-DIR

Conditions for starting printing or cutting

The material must be already set up (with the SETUP LED lighted), and the display must show the top menu. If another menu screen is displayed, press the [SETUP] key to go back to the top menu. (Pressing the [SETUP] key when another menu screen is displayed does not cancel the set-up for the material.)

Are the computer and the machine linked with the right cable ?

The type of cable you need is determined by your computer. One which you are sure matches the model of computer being used should be select.

Is the cable making a secure connection?

Connect securely. (See “What to Do upon Opening the Carton -- 2 Setting Up and Connection” .)

Has the correct driver selection been made for the application software?

Select the appropriate driver.

If the "INK EMPTY" message appears

A cartridge has run out of ink, and printing cannot be started.

If printing data is being sent, this message is displayed and the buzzer sounds. At the same time, operation is paused and the PAUSE LED flashes. Replace the empty cartridge with a new one and press the [PAUSE] key to start printing.

The message “SHEET TOO SHORT CONTINUE?” appears when data is sent from the computer

The size of the data is larger than the printing/cutting area of the loaded material.

To continue performing output without correcting this, press the [ENTER] key. When you do this, portions that extend beyond the printing/cutting area are not output.

To stop output, stop sending data from the computer, then press the [SETUP] key.

Enlarge the printing/cutting area by replacing the material with a larger piece or repositioning the pinch rollers, then send the data again.

The message “CAN’T PRINT CROP CONTINUE?” appears when data is sent from the computer

The size of the data including the crop marks is larger than the printing/cutting area of the loaded material.

To continue performing output without correcting this, press the [ENTER] key. When you do this, crop marks and portions that extend beyond the printing/cutting area are not output.

To stop output, stop sending data from the computer, then press the [SETUP] key.

Enlarge the printing/cutting area by replacing the material with a larger piece or repositioning the pinch rollers, then send the data again.

Clean, attractive printing is impossible

If drop-out occurs with printed images.

Clean the printing heads (see "Maintenance -- Cleaning the Printing Heads").

Is the surface of the platen dirty or scratched?

Clean the platen (see “Maintenance -- When the Product Needs Cleaning”).

Is the material dirty?

Remove superficial soiling, then load the material.

Is the material damaged?

Clean, attractive printing is not possible if the material is damaged or warped.

Use care to keep materials from being damaged while in storage.

During printing, was the front cover opened (executing an emergency stop) or the [PAUSE] key pressed?

If operation is stopped or paused while printing is in progress, the quality of the image before and after the interruption may differ. It is a good idea to avoid pausing operation while printing is in progress whenever possible.

Is thick material in use, or does the surface of the material rub against the printing heads?

If material feed is not smooth because the material catches on the head, then adjust the height of the printing heads (see "User's Reference -- Adjusting the Height of the Printing Head").

When the height of the printing head has been adjusted, it is necessary to perform bidirectional correction (only when the printing direction for [PRINT MODE] has been set to [BI-DIRECTION]). For more information about bidirectional correction, see "User's Reference -- Making Corrections for Printing -- Bidirectional Correction."

If the type of material was changed, was feed correction performed?

Correcting the amount of feed improves the dot-positioning accuracy in the feed direction, which can help enhance image quality.

If the type of material was changed, refer to "User's Reference -- Making Corrections for Printing -- Feed Correction" and perform correction for feed.

Printing goes beyond the loaded material

Has the material been loaded at an angle?

If the loaded material is not straight, it may extend outside the printing area.

In “Setup for Printing” or “Setup for Cutting,” refer to “1 Loading the Material” and load the material correctly.

The Material is not cut properly

Are the blade and blade holder installed correctly and securely?

Install these so that there is no looseness (see “Setup for Cutting -- Installing the Cutter”).

Is the blade chipped?

If it is, replace it with a new one (see “Maintenance -- Replacing the Cutter Blade”).

Check if there are any dirty deposits on the blade.

If dirty, remove and clean the blade.

Make sure you are using an appropriate cutter force setting.

Perform a “test cutting,” then adjust to the optimum cutter force (see “Setup for Cutting -- Test Cutting”).

Material feed is not smooth (slippage occurs)

Is thick material being used?

If the surface of the material rubs against the printing heads and smooth feed is impossible, then adjust the height of the printing heads (see “User's Reference -- Adjusting the Height of the Printing Head”).

When the height of the printing head has been adjusted, it is necessary to perform bidirectional correction (only when the printing direction for [PRINT MODE] has been set to [BI-DIRECTION]). For more information about bidirectional correction, see “User's Reference -- Making Corrections for Printing -- Bidirectional Correction.”

Does a piece of flat material touch the shaft or roll material at the back of the machine?

When loading flat material, if the material touches the shaft or roll material at the back of the machine, remove the shaft and roll material. If the material touches an obstruction while printing is in progress, normal material feed is not performed, and image quality may suffer or the material may jam.

Is the sheet material loaded at an angle? Are the left and right edges of the material not straight?

If the material is loaded at an angle or if the left and right sides of the material are not cut straight, the location of the edges may shift as feed is carried out. This may cause the material to rub against the inner side of the unit or be displaced from the printing/cutting area.

Is the roll material loaded correctly?

If the roll material is not loaded correctly, the material may come loose or advance at an angle. In “Setup for Printing” or “Setup for Cutting,” refer to “1 Loading the Material” and load the material correctly.

Has the sheet loading lever been moved all the way to “LOAD?”

If the sheet loading lever is moved only part of the way, only the right-hand pinch roller is not lowered. Make sure the left- and right-hand pinch rollers are inside the edges of the material then move the level all the way to “LOAD.”

If the material is to be advanced over a long distance,

Movable pinch roller inward slightly can help prevent the material from becoming dislodged.

The material becomes jammed

If [MOTOR ERROR : TURN OFF POWER] appears and operation stops

- (1) Press the [POWER] key to switch off the sub power.
- (2) Remove the jammed material. Cut off any creased or torn portions.
- (3) Correct whatever caused the material to jam.
(For example, if thick material has been loaded, then adjust the height of the printing heads.)
- (4) Press the [POWER] key to turn on the sub power.
- (5) Load the material and carry out setup.
- (6) Press the [CLEANING] key to perform head cleaning (see "Maintenance -- Cleaning the Printing Heads").
- (7) Press the [TEST PRINT] key to perform a printing test (see "Maintenance -- Cleaning the Printing Heads").
- (8) Send the printing data and perform printing.

* Jammed material may damage or soil the printing heads. Be sure to perform head cleaning first before sending the printing or cutting data.

When printing was continued, but should be started over

- (1) Press the [PAUSE] key to pause operation.
- (2) Stop sending data from the computer.
- (3) Press the [SETUP] key. Hold down for about 1 second (making the SETUP LED go dark).
- (4) Press the [POWER] key to switch off the sub power.
- (5) Remove the jammed material. Cut off any creased or torn portions.
- (6) Correct whatever caused the material to jam.
(For example, if thick material has been loaded, then adjust the height of the printing heads.)
- (7) Press the [POWER] key to turn on the sub power.
- (8) Load the material and carry out setup.
- (9) Press the [CLEANING] key to perform head cleaning (see "Maintenance -- Cleaning the Printing Heads").
- (10) Press the [TEST PRINT] key to perform a printing test (see "Maintenance -- Cleaning the Printing Heads").
- (11) Send the printing data and perform printing.

* Jammed material may damage or soil the printing heads. Be sure to perform head cleaning first before sending the printing or cutting data.

Printed lines are misaligned

[Example]

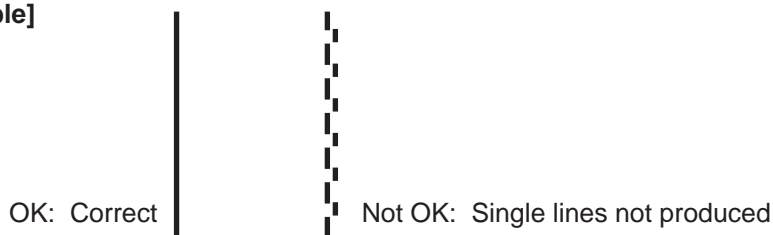

If misalignment like in the example occurs when the printing direction for [PRINT QUALITY] has been set to [BI-DIRECTION] (bidirectional), then carry out correction at the [BIDIRECTION] menu (see "User's Reference -- Making Corrections for Printing -- Bidirectional Correction").

Be sure to make this adjustment when you have replaced the material with a different type or adjusted the head height.

The material cannot be separated

Is a blade installed in the separating knife?

If no blade is installed, then install one (see "Maintenance -- How to Replace the Separating Knife").

Is the blade dull or broken?

If the blade has become dull or broken, replace it with the replacement blade included with the unit (see "Maintenance -- How to Replace the Separating Knife").

* Some materials cannot be separated due to their composition.

Has the [AUTO SHEET CUT] menu item been set to [ENABLE]?

If the material-cutting command has been set to "enable" with the driver, then set [AUTO SHEET CUT] to [ENABLE] (see "Remove the Material -- Cut the material from the roll").

Has the material-cutting command been set to "enable" with the driver?

When the material-cutting command has not been set to "enable" with the driver, automatic separation of the material is not performed, even when [AUTO SHEET CUT] has been set to [ENABLE].

The printing and cutting positions are not aligned

Is the material loaded correctly?

If the material is not loaded correctly, the material meanders as it is fed, and the printing and cutting positions become misaligned. In "Setup for Printing" or "Setup for Cutting," refer to the section "1 Loading the Material" and load the material correctly.

The printing and cutting positions in direction of carriage movement are misaligned

The printing length in the carriage direction may change depending on the operating environment (temperature and humidity). Execute [ENV. MATCH] to adjust the machine to match the operating environment. (Refer to "Environment Matching.")

Error Messages

Error messages	Meaning	Action
MOTOR ERROR TURN OFF POWER	A motor error occurred.	Recovery from this problem is impossible. Use the POWER key to switch the power off and back on again. After rectifying the cause of the error (a material jam or the like), switch on the power. Do not leave the unit with the carriage not in standby position.
TEMPERATURE IS TOO HIGH	The air temperature where installed is higher than the ambient temperature at which the unit can operate (approx. 40°C (104°F) or more higher).	Recovery from this problem is impossible. Use the [POWER] key to switch the power off. First raise the temperature of the area where installed, then switch on the power.
TEMPERATURE IS TOO LOW	The air temperature where installed is lower than the ambient temperature at which the unit can operate (approx. 5°C (41°F) or more lower).	Recovery from this problem is impossible. Use the [POWER] key to switch the power off. First raise the temperature of the area where installed, then switch on the power.
INVALID SHEET SET SHEET AGAIN	The [SETUP] key was pressed even though no material is loaded. Setup was performed with no material at the correct location. [EDGE SENSE] is set to [ENABLE], but transparent material was loaded.	Load material at the correct location and press the [SETUP] key again. When using transparent material, set [EDGE SENSE] to [DISABLE] (see "Description of Menus").
SHEET TOO SMALL SET SHEET AGAIN	An attempt was made to load material that is too small.	Replace with material of loadable size.
PINCHROLL ERROR DOWN PINCHROLL	The [SETUP] key was pressed with the pinch rollers up. The pinch rollers were raised during setup.	Move the sheet loading lever all the way to "LOAD" to lower the pinch rollers, then press the [SETUP] key (see "Loading the Material").
PINCHROLL ERROR INVALID RIGHTPOS	The [SETUP] key was pressed while the right-hand pinch roller was at a location where there is no grit roller.	Position the right-hand pinch roller correctly (above a grit roller), then press the [SETUP] key.
PINCHROLL ERROR INVALID LEFTPOS	The [SETUP] key was pressed while the right-hand pinch roller was at a location where there is no grit roller.	Position the left-hand pinch roller correctly (above a grit roller), then press the [SETUP] key.
BASE POINT ERROR	An attempt was made to set the print-start location at a position beyond the printing/cutting area.	Use the arrow keys to move the carriage marker to a place within the printing area, then press the [BASE POINT] key (see "User's Reference -- Performing Printing/Cutting at the Desired Location").
ALIGN WIDTH ERROR	An attempt was made to set the align point at the same location as the base point.	Set the align point at a proper position (see "User's Reference -- Remove the Printed Material, then Reload the Material and Perform Cutting").
ALIGN ANGLE ERROR	An attempt was made to set the align point at a location described below. <ul style="list-style-type: none"> • Tilted 5 degrees or more from the base point • Separated from the base point by 20 mm (13/16 in.) or more in the feed direction 	Set the align point at a proper position (see "User's Reference -- Remove the Printed Material, then Reload the Material and Perform Cutting").

Error messages	Meaning	Action
CURSOR POS. ERROR OUT OF AREA	An attempt was made to perform a printing or cutting test outside the printing or cutting area.	Perform the printing or cutting test inside the printing or cutting area.
ILLEGAL SHUTDOWN TURN OFF POWER	The main power switch was turned off without first turning off the sub power with the [POWER] key.	Press the [POWER] key to turn off the sub power, then turn on the power again.

Specifications

		SC-500
Printing/Cutting method		Piezo ink-jet method/media-moving method
Printing/Cutting area		1346.2 mm x 24998 mm (53 in. x 984-1/8 in.)
Acceptable material widths	Sheet material	131 to 1371 mm (5-3/16 to 54 in.) (Note that detection of the front and rear edges is not possible for material measuring from 131 mm to 430 mm (5-3/16 to 17 in.))
	Roll material	131 to 1371 mm (5-3/16 to 54 in.) (Note that detection of the front and rear edges is not possible for material measuring from 131 mm to 430 mm (5-3/16 to 17 in.))
Width of material that can be cut off		131 to 1371 mm (5-3/16 to 54 in.)
Conditions for usable materials		Cutable material thickness: 0.08 to 0.22 mm (0.00315 to 0.00866 in.) (depending on material composition) Maximum cutable material thickness including base paper: 0.4 mm (0.0157 in.) Maximum printable material thickness including base paper: 1.0 mm (0.039 in.) (when head is raised to maximum) Maximum diameter for roll material: 180 mm (7-1/16 in.) Core inner diameter for roll material: 50.8 mm (2 in.) or 76.2 mm (3 in.) Maximum weight for roll material: 20 kg (44.1 lb.)
Ink cartridges	Type	Exclusive SOL INK cartridge
	Capacity	220 cc ±5 cc
	Color	Six colors: cyan, magenta, yellow, black, light cyan and light magenta
Apparent colors		16.7 million colors
Printing resolution (Printing dot resolution)		1440 dpi x 720 dpi / 720 dpi x 720 dpi / 540 dpi x 540 dpi / 360 dpi x 720 dpi / 180 dpi x 720 dpi
Distance accuracy (When printing)		Error of less than ±0.3% of distance traveled, or 0.3 mm, whichever is greater (at Roland PET-film, print travel: 1 m (39-3/8 in.))
Acceptable tool		Cutter (blade and blade holder): Special blade for CAMM-1 series
Cutting speed		10 to 600 mm/s (10 to 300 mm/s in the material-feed direction)
Blade force		30 to 200 gf
Blade offset compensation		0.000 to 1.500 mm (0 to 0.0591 in.)
Software resolution (When cutting)		0.025 mm/step (0.00984 in./step)
Distance accuracy (When cutting)		Error of less than ±0.4% of distance traveled, or 0.3 mm, whichever is greater When distance correction has been performed (when the setting for [CALIBRATION] - [CUTTING ADJ.] has been made): Error of less than ±0.2% of distance traveled, or 0.1 mm, whichever is greater
Repetition accuracy (When cutting)		0.1 mm or less (excluding stretching/contraction of the material) Range for assured repetition accuracy (*) For materials with a width exceeding 610 mm (24 in.): Length 4,000 mm (157-7/16 in.) For materials with a width of 610 mm (24 in.) or less : Length 8,000 mm (315-15/16 in.)
Repetition between printing and cutting		±0.5 mm (±0.0197 in.) max. at 25°C (excluding possible shift caused by expansion/contraction of the material and/or by reloading the material, and provided that material length is under 3000 mm (118-1/16 in.))
Printing heads cleaning		Automatic cleaning and manual cleaning
Interface		Bidirectional parallel interface (compliant with IEEE 1284: nibble mode)
Instruction system		RD-GL III (Cutting), RD-RTL (Printing), RD-PJL
Power-saving function		Auto-sleep
Power consumption	Printing/Cutting mode	Maximum: 1.0A/100V to 240V ±10% 50/60 Hz
	Standby mode	Maximum: 0.4A/100V to 240V ±10% 50/60 Hz
Acoustic noise level	Printing/Cutting mode	64dB (A) or less (According to ISO7779)
	Standby mode	40dB (A) or less (According to ISO7779)

Continued on the next page
For items indicates by an asterisk "(*)", please see the next page.

Dimensions	Main unit	2325 mm [W] x 381 mm [D] x 428 mm [H] (91-9/16 in. [W] x 15 in. [D] x 16-7/8 in. [H])
	With stand	2325 mm [W] x 736 mm [D] x 1287 mm [H] (91-9/16 in. [W] x 29 in. [D] x 50-11/16 in. [H])
Packed dimensions	Main unit	2625 mm [W] x 630 mm [D] x 720 mm [H] (103-3/8 in. [W] x 24-13/16 in. [D] x 28-3/8 in. [H])
	Stand	857 mm [W] x 845 mm [D] x 293 mm [H] (33-3/4 in. [W] x 33-1/4 in. [D] x 11-9/16 in. [H])
Weight	Main unit	85 kg (187.4 lb.)
	With stand	105 kg (231.5 lb.)
Packed weight	Main unit	103 kg (227.1 lb.)
	Stand	42 kg (92.6 lb.)
Environment	Power on	Temperature: 15 to 35 °C (59 to 95 °F), Humidity: 35 to 80 % (non-condensing)
	Power off	Temperature: 5 to 40 °C (41 to 104 °F), Humidity: 20 to 80 % (non-condensing)
Accessories	Power cord: 1, Drain bottle: 2, Drain-bottle cap: 1, Screws: 2, Blade: 1, Blade Holder: 1, Replacement blade for separating knife: 1, Cleaning kit: 1, Roland COLORCHOICE®: 1, User's manual: 1	

(*) The following conditions must be satisfied:

- Material type: 3M Scotchcal Mastercut Film, ARLON Series 2100
- Special stand (Roll material must be loaded on the shaft)
- Side margins: 25 mm (1 in.) or more for both the left and right margins
- Front margin: 35 mm (1-1/8 in.) or more
(After loading the material, when the material type to [EDGE] with the display menu, the front margin is automatically set to 35 mm (1-1/8 in.))
- The [PREFEED] function on the display menu must be set to [ENABLE]
- Cutting of the following data one time

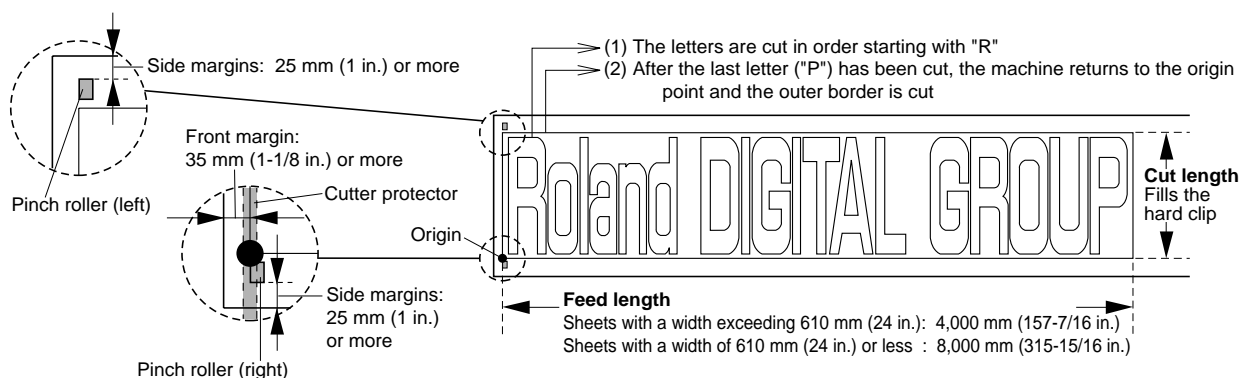

Interface Specifications

Standard	Bidirectional parallel interface (compliant with IEEE 1284: nibble mode)
Input signals	$\overline{\text{STROBE}}$ (1BIT), DATA (8BITS), $\overline{\text{SLCT IN}}$, $\overline{\text{AUTO FEED}}$, $\overline{\text{INIT}}$
Output signals	BUSY (1BIT), $\overline{\text{ACK}}$ (1BIT), $\overline{\text{FAULT}}$, SLCT, PERROR
Level of input output signals	TTL level
Transmission method	Asynchronous

Parallel Connector (in compliance with specifications of Centronics)

Signal number	Terminal number		Signal number
$\overline{\text{SLCT IN}}$	36	18	HIGH***
HIGH*	35	17	GND
NC	34	16	GND
GND	33	15	NC
$\overline{\text{FAULT}}$	32	14	$\overline{\text{AUTO FEED}}$
$\overline{\text{INIT}}$	31	13	SLCT
GND	30	12	PERROR
	29	11	BUSY
	28	10	$\overline{\text{ACK}}$
	27	9	D7
	26	8	D6
	25	7	D5
	24	6	D4
	23	5	D3
	22	4	D2
	21	3	D1
	20	2	D0
	19	1	$\overline{\text{STROBE}}$

Pin Connection

