

SP-540V ECO-SOL INK MODEL

SETUP GUIDE

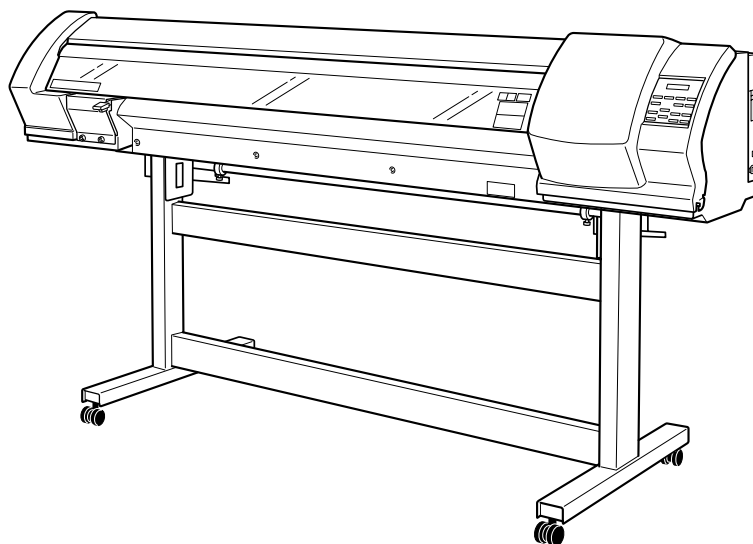



Read this first.

This describes the setup tasks and important conditions about the installation location that must be met in order to enable use of this machine.

Thank you very much for purchasing this product.

- To ensure correct and safe usage with a full understanding of this product's performance, please be sure to read through this manual completely and store it in a safe location.
- Unauthorized copying or transferral, in whole or in part, of this manual is prohibited.
- The contents of this operation manual and the specifications of this product are subject to change without notice.
- The operation manual and the product have been prepared and tested as much as possible. If you find any misprint or error, please inform us.
- Roland DG Corp. assumes no responsibility for any direct or indirect loss or damage which may occur through use of this product, regardless of any failure to perform on the part of this product.
- Roland DG Corp. assumes no responsibility for any direct or indirect loss or damage which may occur with respect to any article made using this product.

Table of Contents

| | |
|---|-----------|
|  To Ensure Safe Use | 2 |
|  Pour utiliser en toute sécurité | 7 |
| Setup Guide | 13 |
| 1. Included Items | 14 |
| 2. Installation Environment | 15 |
| Deciding On an Installation Site | 15 |
| Temperature and Humidity | 16 |
| Installation Space | 16 |
| 3. Assembling and Installing | 17 |
| Assemble the Stand | 17 |
| Install the Arms and Shafts | 19 |
| Install the Drain Bottle | 21 |
| Remove the Packing Materials | 22 |
| 4. Connect the Cables | 23 |
| Set the Voltage Switches | 23 |
| Connect the Cables | 24 |
| 5. Install the Ink Cartridges | 26 |
| Filling with Ink for the First Time | 26 |
| Installing the Ink Cartridges | 26 |
| 6. Match the Machine to the Environment | 30 |
| 7. Install the Blade | 31 |
| 8. When Not in Use for a Prolonged Period | 33 |
| Keep Performing Maintenance | 33 |
| Alarm Feature | 33 |
| 9. When Moving the Unit | 34 |
| Procedures from Preparing to Move Through Reinstalling | 34 |

Company names and product names are trademarks or registered trademarks of their respective holders.



Copyright© 2004 Roland DG Corporation

<http://www.rolanddg.com/>







To Ensure Safe Use

Improper handling or operation of this machine may result in injury or damage to property. Points which must be observed to prevent such injury or damage are described as follows.

About WARNING and CAUTION Notices

| | |
|--|--|
|  WARNING | Used for instructions intended to alert the user to the risk of death or severe injury should the unit be used improperly. |
|  CAUTION | Used for instructions intended to alert the user to the risk of injury or material damage should the unit be used improperly. * Material damage refers to damage or other adverse effects caused with respect to the home and all its furnishings, as well to domestic animals or pets. |

About the Symbols

| | |
|---|--|
|  | The  symbol alerts the user to important instructions or warnings. The specific meaning of the symbol is determined by the design contained within the triangle. The symbol at left means "danger of electrocution." |
|  | The  symbol alerts the user to items that must never be carried out (are forbidden). The specific thing that must not be done is indicated by the design contained within the circle. The symbol at left means the unit must never be disassembled. |
|  | The  symbol alerts the user to things that must be carried out. The specific thing that must be done is indicated by the design contained within the circle. The symbol at left means the power-cord plug must be unplugged from the outlet. |

 **Incorrect operation may cause injury**

 **WARNING**



Be sure to follow the operation procedures described in this manual.
Failure to follow the procedures may cause sudden operation or the like of the machine, which may result in unexpected injury.



Never allow children near the machine.
The machine includes locations and components that pose a danger to children, and major accident, including injury, blindness, or choking, may occur.



Do not disassemble, repair, or modify.
Doing so may lead to fire or abnormal operation resulting in injury.

 **CAUTION**



Unpacking, and installation must be carried out by four or more persons.
This machine weights approximately 150 kg (330 lb.) Tasks that require undue effort when performed by a small number of persons may result in injury.



Install in a level and stable location.
Failure to do so may result in the unit tipping over, leading to injury.



Never climb or lean on the machine.
The machine is not made to support a person. Climbing or leaning on the machine may move away components and cause in a slip or fall, resulting in injury.



Use the joining screws to secure the unit to the stand.
Failure to do so may result in falling of the unit, leading to injury.



Use care to avoid pinching the fingers when placing the unit on the stand.
Doing so may result in injury.



Release the caster locks for the stand before attempting to move.
Otherwise the unit may tip over and cause injury.

 **Danger of fire, burns, or toxic gas emissions**

 **WARNING**



This machine has high-temperature areas (platen and apron). Exercise caution to avoid fire or burns.



Never leave media loaded in the machine when printing is not being performed.
The continued application of heat at a single location may cause fire or produce toxic gases. When printing is not being performed, switch off the power or remove any loaded media.



Never use media that cannot withstand the heat.
Doing so may result in fire or the release of toxic gases, or may degrade the media.









Never use the platen or apron for any purpose for which they are not intended, such as to dry clothing.
Doing so may cause overheating, resulting in fire or accident.

Danger of electrical short, shock, electrocution, or fire

This machine carries a high current of a maximum of approximately 9 amperes. This can cause situations that could not occur with low-power equipment; use caution.

WARNING

-  **Before switching on the power, set the voltage switch to match the voltage of the region where the unit is used.**
When set incorrectly, the machine may fail to operate normally. The temperature of the print heater and dryer may rise to undue levels, which may result in fire, or the temperature may fail to rise at the correct speed.
-  **Do not use with any electrical power supply that does not meet the ratings displayed on the unit.**
Use with any other power supply may lead to fire or electrocution.
-  **Never operate the machine or insert or remove its power plug with wet hands.**
Doing so may result in electrical shock or electrocution.
-  **Never allow the machine to get wet, or apply gasoline, thinner, or any other flammable material to it.**
Current leakage may cause electrical shock, electrocution, or combustion and fire.
-  **Never allow hairpins, coins, matches, or any other object to get inside the machine through the ventilation ports.**
Doing so may cause an electrical short, resulting in shock or electrocution, or the inserted object may catch fire.
-  **Never place gasoline, alcohol, thinner, or any other flammable material near the machine, or use an aerosol spray close to the machine.**
Doing so may cause fire.
-  **Never damage the power cord or pull it with force.**
Doing so may tear the cord's insulation, causing an electrical short and resulting in electrical shock, electrocution, or fire.
-  **Never place any object on the power cord, bend the power cord using excessive force, or allow the power cord to become deformed.**
If it becomes deformed, the deformed location may grow hot and cause fire.
-  **Never use the machine with the power cord bound into a bundle or roll.**
If the cord is in a bundle or roll, it may grow hot and cause fire.
-  **Never use any power cord other than the power cord included with the machine. Also, never use a power strip or extension cord.**
The power strip or extension cord may grow hot and cause fire.
-  **Do not use with a damaged power cord or plug, or with a loose electrical outlet.**
Doing so may lead to fire, electrical shock, or electrocution.
-  **When unplugging the electrical power cord from the power outlet, grasp the plug, not the cord.**
Unplugging by pulling the cord may damage it, leading to fire, electrical shock, or electrocution.
-  **Ground the unit with the ground wire.**
Failure to do so may result in risk of electrocution in the event of a mechanical problem.
-  **In the event of an abnormal state (such as smoke or sparks, odor or burning or unusual noise), immediately unplug the power cord.**
Failure to do so may result in fire, electrical shock, or electrocution. Immediately disconnect the power cord and contact your Roland DG Corp. service center.

 **Ink, cleaning liquid, and discharged fluid are flammable and toxic**

 **WARNING**



If you're using a model that uses ECO-SOL INK, never operate in locations such as those near an open flame or heater, or where sparking or static electricity may occur.

Ink or the like may ignite and cause fire.



If you're using a model that uses ECO-SOL INK, never place ink, cleaning liquid, or discharged fluid in any of the following locations.

- > Near open flame
- > In a hot location, such as near a heater or on the machine's platen or apron
- > Near bleach, chemicals, explosives, or the like

Doing so may cause fire.

 **CAUTION**



Ensure adequate ventilation for the work area.

Odor from ink and the like may cause physical distress, or may cause to fire.



Never drink or sniff ink, cleaning liquid, or discharged fluid, or allow them to come in contact with the eyes or skin.

Doing so may be hazardous to your health.



Store ink cartridges in a location out of the reach of children.

 **In the Event of Ingestion or Physical Distress**

- > In the event of contact with the eyes, immediately flush with running water for at least 15 minutes. If eye irritation continues, seek treatment by a physician.
- > In the event of contact with skin, immediately wash with soap. If irritation or inflammation occur, seek treatment by a physician.
- > In the event of ingestion, do not induce vomiting, and immediately seek treatment by a physician. Forcibly inducing vomiting may lead to danger of choking.
- > If odor leads to physical distress, move to a well-ventilated location and rest quietly. If dizziness or nausea persists, seek treatment by a physician.

Warning Labels

Warning labels are affixed to make areas of danger immediately clear. The meanings of these labels are as follows. Be sure to heed their warnings.

Also, never remove the labels or allow them to become obscured.

Front

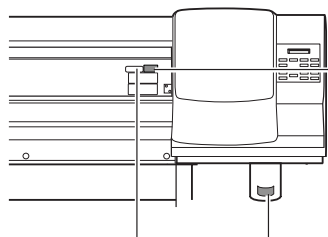

Caution: Moving Carriages

The print-heads carriage and the cutting carriage inside the cover move at high speed and pose a hazard. Never insert the hand or fingers into the gap.

Left

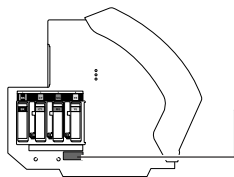

Flammable

Ink and discharged fluid are flammable. Keep away from open flame.



Ink Is Toxic

Ink and discharged fluid are toxic. Avoid contact with the body. Use only in a well-ventilated area.

Ink cartridge

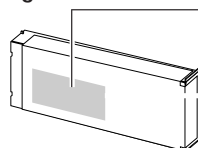

Inside the front cover

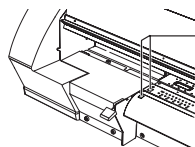



Caution: High Temperature

The platen and apron become hot. Exercise caution to avoid fire or burns.







Pour utiliser en toute sécurité

La manipulation ou l'utilisation inadéquates de cet appareil peuvent causer des blessures ou des dommages matériels. Les précautions à prendre pour prévenir les blessures ou les dommages sont décrites ci-dessous.

Avis sur les avertissements

| | |
|--|--|
|  ATTENTION | Utilisé pour avertir l'utilisateur d'un risque de décès ou de blessure grave en cas de mauvaise utilisation de l'appareil. |
|  PRUDENCE | Utilisé pour avertir l'utilisateur d'un risque de blessure ou de dommage matériel en cas de mauvaise utilisation de l'appareil. * Par dommage matériel, il est entendu dommage ou tout autre effet indésirable sur la maison, tous les meubles et même les animaux domestiques. |

À propos des symboles

| | |
|---|--|
|  | Le symbole  attire l'attention de l'utilisateur sur les instructions importantes ou les avertissements. Le sens précis du symbole est déterminé par le dessin à l'intérieur du triangle. Le symbole à gauche signifie "danger d'électrocution". |
|  | Le symbole  avertit l'utilisateur de ce qu'il ne doit pas faire, ce qui est interdit. La chose spécifique à ne pas faire est indiquée par le dessin à l'intérieur du cercle. Le symbole à gauche signifie que l'appareil ne doit jamais être démonté. |
|  | Le symbole  prévient l'utilisateur sur ce qu'il doit faire. La chose spécifique à faire est indiquée par le dessin à l'intérieur du cercle. Le symbole à gauche signifie que le fil électrique doit être débranché de la prise. |

L'utilisation incorrecte peut causer des blessures

ATTENTION



S'assurer de suivre les procédures d'utilisation décrites dans ce manuel.

Si les procédures indiquées ne sont pas suivies, le fonctionnement de l'appareil peut être déclenché soudainement, ce qui risque de causer des blessures.



Ne jamais laisser d'enfants s'approcher de l'appareil.

Des éléments et des surfaces de l'appareil présentent des risques pour les enfants. Il pourrait se produire un accident grave qui causerait des blessures, ou créerait un risque de cécité ou de suffocation.



Ne pas démonter, réparer ni modifier.

Démonter, réparer ou modifier l'appareil risque de provoquer un incendie ou de causer un fonctionnement anormal entraînant des blessures.

PRUDENCE



Le déballage, l'installation et le déplacement de l'appareil doivent être effectués par quatre personnes ou plus.

Le poids de cet appareil est d'environ 150 kg (330 lb.) Les tâches qui exigent un effort trop grand si elles sont exécutées par un petit nombre de personnes peuvent être cause de blessures.



Installer sur une surface stable et de niveau.

Sinon, l'appareil risque de se renverser et de causer des blessures.



Ne jamais grimper ni s'appuyer sur l'appareil.

L'appareil n'est pas conçu pour supporter le poids d'une personne. Grimper ou s'appuyer sur la machine peut déplacer des éléments et causer un faux pas ou une chute, ce qui causerait des blessures.



Utiliser les vis fournies pour bien fixer l'appareil sur le support.

Le non-respect de cette consigne pourrait causer des défauts dans l'appareil entraînant des blessures.



Manipuler avec précaution pour éviter de se coincer les doigts lors de l'installation de l'appareil sur le support.

Une négligence à ce niveau pourrait provoquer des blessures.



Débloquer le mécanisme d'arrêt des roulettes du support avant de le déplacer.

Sinon l'appareil pourrait se renverser et provoquer des blessures.

 **Risque d'incendie, de brûlures ou d'émissions de gaz toxiques**

 **ATTENTION**



Des surfaces de cet appareil atteignent des températures élevées (éléments de chauffage et tablier). Prendre des précautions pour éviter un incendie ou des brûlures.



Ne jamais laisser de support dans l'appareil quand aucune impression n'est en cours.

L'application continue de chaleur au même endroit peut provoquer un incendie ou l'émission de gaz toxiques. Quand l'appareil n'est pas utilisé, couper l'alimentation ou retirer les supports qui y sont chargés.



Ne jamais utiliser un support qui ne peut pas supporter la chaleur.

L'utilisation de supports qui ne supportent pas la chaleur peut causer un incendie, provoquer l'émission de gaz toxiques ou affecter le support.



Ne jamais utiliser les éléments de chauffe ni le tablier à des fins autres que celles pour lesquelles ils sont conçus, par exemple, ne pas les utiliser sécher des vêtements.

L'utilisation à ces fins risque de causer une surchauffe et de provoquer un incendie ou un accident.

Risque de décharge ou de choc électrique, d'électrocution ou d'incendie

Cet appareil transmet une tension élevée (maximum d'environ 9 ampères). Cela peut créer des situations qui ne se produisent pas avec de l'équipement à basse tension. La prudence est de mise.

ATTENTION



Avant de mettre l'appareil sous tension, régler le sélecteur de tension sur la tension locale.

Le chauffage risque de ne pas fonctionner normalement si la tension n'est pas correctement sélectionnée. La température des éléments de chauffe et de séchage peut augmenter anormalement et provoquer un incendie, ou bien la température peut ne pas augmenter à la vitesse correcte.



Ne pas utiliser avec une source d'alimentation électrique non conforme à la norme indiquée sur l'appareil.

Utiliser l'appareil avec une autre source d'alimentation risque de provoquer un incendie ou de causer une électrocution.



Ne jamais utiliser l'appareil, insérer la prise dans le réceptacle ou l'en enlever si on a les mains mouillées.

Il y a risque de décharge électrique ou d'électrocution.



Ne jamais permettre que l'appareil soit mouillé; ne jamais y appliquer d'essence, de diluant ni aucun matériau inflammable.

Une fuite de courant peut causer un choc électrique, l'électrocution ou la combustion et un incendie.



Ne jamais laisser des épingles à cheveux, des pièces de monnaie, des allumettes ni aucun autre objet pénétrer dans l'appareil par les orifices de ventilation.

Cela crée un risque de décharge électrique ou d'électrocution. En outre, les objets peuvent prendre feu.



Ne jamais placer de l'essence, du diluant ni aucun matériau inflammable près de l'appareil; ne jamais utiliser de produits en aérosol près de l'appareil.

Cela crée un risque d'incendie.



Ne jamais endommager le câble d'alimentation ni le tirer vigoureusement.

Cela risque de déchirer l'isolant du câble et de causer un court-circuit, ce qui aurait comme résultat un choc électrique, l'électrocution ou un incendie.



Ne jamais placer d'objets sur le cordon d'alimentation, plier le câble d'alimentation en utilisant une force excessive ni laisser le câble d'alimentation se déformer.

Si le câble se déforme, la section affectée peut surchauffer et causer un incendie.



Ne jamais utiliser l'appareil si le câble d'alimentation est attaché ou enroulé.

S'il est attaché ou enroulé, il peut surchauffer et causer un incendie.



Ne jamais utiliser un cordon d'alimentation autre que celui qui est fourni avec l'appareil. Ne jamais non plus utiliser de bande d'alimentation électrique ni de rallonge.

La bande d'alimentation ou la rallonge peuvent surchauffer et causer un incendie.



Ne pas utiliser si le fil ou la fiche électriques sont endommagés; ne pas brancher dans une prise mal fixée.

Négliger de suivre cette consigne risque de provoquer un incendie ou de causer une décharge électrique ou une électrocution.



Pour débrancher l'appareil, saisir la fiche et non le fil électrique.

Tirer sur le fil peut l'endommager, ce qui risque de provoquer un incendie ou de causer une décharge électrique ou une électrocution.

⚠ ATTENTION



Mettre l'appareil à la terre avec le fil de mise à la terre.

Ne pas respecter cette consigne peut créer un risque d'électrocution en cas de panne mécanique.



S'il se produit quoi que ce soit d'anormal (fumée, étincelles, odeur, combustion ou bruit inhabituel), débrancher immédiatement le câble d'alimentation.

Le défaut de ce faire peut entraîner un incendie, un choc électrique ou l'électrocution. Débrancher immédiatement le câble d'alimentation et communiquer avec le Centre de services Roland DG.

⚠ L'encre, les liquides nettoyants et les liquides usés sont inflammables et toxiques

⚠ ATTENTION



Si l'appareil est un modèle qui utilise ECO-SOL INK, ne pas l'utiliser près d'une flamme nue, dans un endroit où se produisent des étincelles ou de l'électricité statique, ni dans un endroit où les températures sont élevées, par exemple à proximité d'un appareil de chauffage.

L'encre ou les autres produits combustibles peuvent s'enflammer et causer un incendie. La combustion de l'encre ou du liquide nettoyant peut créer un risque d'incendie.



Si l'appareil est un modèle qui utilise ECO-SOL INK, ne jamais placer d'encre, de liquide de nettoyage ou des liquides usés dans les endroits suivants :

- > près d'une flamme nue
- > dans un endroit chaud, par exemple près d'un appareil de chauffage, sur les éléments de chauffage ou de séchage de l'appareil;
- > près de javellisants, de produits chimiques, d'explosifs ou d'autres produits semblables

Cela crée un risque d'incendie.

⚠ PRUDENCE



S'assurer que le lieu de travail est bien aéré.

L'odeur de l'encre et des autres produits peut causer des troubles physiques ou provoquer un incendie.



Ne jamais boire l'encre, le liquide de nettoyage ni les liquides usés, ne pas en respirer les vapeurs et ne pas laisser les produits entrer en contact avec les yeux ou la peau.

Cela est dangereux pour la santé.



Entreposer les cartouches dans un endroit hors de la portée des enfants.

⚠ En cas d'ingestion ou de trouble physique

- > En cas de contact avec les yeux, rincer immédiatement et abondamment à l'eau courante pendant au moins 15 minutes. Si les yeux sont toujours irrités, consulter un médecin.
- > En cas de contact avec la peau, laver immédiatement à l'eau et au savon. Si la peau devient irritée ou enflammée, consulter un médecin.
- > En cas d'ingestion, ne pas provoquer le vomissement et demander immédiatement l'aide d'un médecin. Provoquer le vomissement peut créer un risque de suffocation.
- > Si l'odeur cause un trouble physique, amener la personne dans un endroit bien aéré et la faire se reposer. Si l'étourdissement ou les nausées persistent, consulter un médecin.

⚠ Vignettes d'avertissement

Des vignettes d'avertissement sont apposées pour qu'il soit facile de repérer les zones dangereuses. La signification des vignettes est donnée ci-dessous. Respecter les avertissements. Ne jamais retirer les vignettes et ne pas les laisser s'encrasser.

Avant

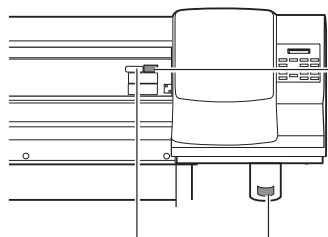

Attention : Chariots mobiles

Le chariot des têtes d'impression et le chariot de coupe sous le couvercle se déplacent à haute vitesse et représentent un danger. Ne jamais insérer la main ou les doigts dans l'ouverture.

Gauche

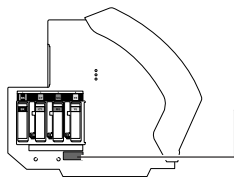

Inflammable

L'encre et les liquides usés sont inflammables. Les garder loin de toute flamme nue.



L'encre est toxique

L'encre et les liquides usés sont toxiques. Éviter tout contact avec le corps. Utiliser uniquement dans un endroit bien aéré.

La cartouche d'encre

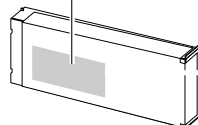

Intérieur de le couvercle

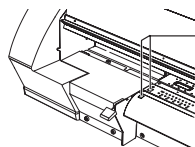

Attention : Température élevée

La platine et la surface de séchage chauffent. Être prudent pour éviter un incendie ou des brûlures.

Setup Guide

1. Included Items

The following items are packed together with the unit. Make sure they are all present and accounted for.



Power cord: 1

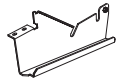

Arm (right): 1

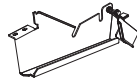

Arm (left): 1

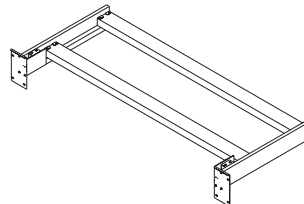

Stand leg: 1

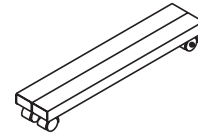

Casters: 2



Shafts: 2



Stoppers: 4

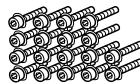

Bolts: 18



Hexagonal wrench: 1



Pipe: 1

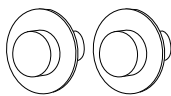

Media flanges: 2

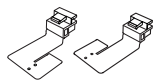

Short media clamps : 2
(left and right) (*1)

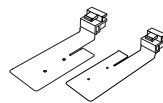

Long media clamps : 2
(left and right)

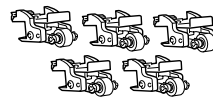

Middle pinch rollers: 5
(*2)



Blade: 1

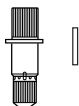

Blade holder: 1
Pin: 1



Replacement blade for
separating knife: 1



Drain bottles: 2

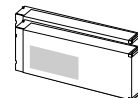

SOL INK cleaning
cartridges: 2



Software RIP: 1 set



Roland Cut Driver
CD-ROM: 1



Roland-PrintServer
CD-ROM: 1

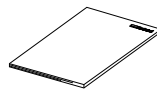

User's Manual: 1

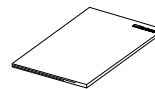

Setup Guide: 1
(this document)



Roland-PrintServer
Network Setup Guide: 1

Cleaning kit



Cleaning sticks: 10



Tweezers: 1



Replacement wipers: 2

*1 The short media clamps are installed on the machine.

*2 The two middle pinch rollers are installed on the machine.

2. Installation Environment

Deciding On an Installation Site

Install in a quiet, stable location offering good operating conditions. An unsuitable location can cause accident, fire, faulty operation, or breakdown.

⚠ WARNING never operate in locations such as those near an open flame or heater, or where sparking or static electricity may occur.
Ink or the like may ignite and cause fire.

⚠ CAUTION Install in a level and stable location.
Otherwise the machine may tip over and cause injury.

⚠ CAUTION Install in a location that can be ventilated.
Odor from ink and the like may cause physical distress, or may cause to fire.

Unsuitable Installation Sites

- > Locations subject to large fluctuations in temperature or humidity
- > Locations subject to shaking or vibration
- > Locations where the floor is tilted, not level, or unstable
- > Dusty locations
- > Locations exposed to direct sunlight or near air-conditioning or heating equipment
- > Locations exposed to water or moving air
- > Locations exposed to considerable electrical or magnetic noise, or other forms of electromagnetic energy

2. Installation Environment

Temperature and Humidity

Maintain the specified temperature and humidity even when the machine is not in use. Temperatures that are too high may degrade the ink and cause malfunction. Temperatures that are too low may cause the ink to freeze and damage the heads.

During operation: Temperature 20 to 32°C (68 to 89.6°F), relative humidity 35 to 80% (no condensation)

During nonoperation: Temperature 5 to 40°C (41 to 104°F), relative humidity 20 to 80% (no condensation)

Installation Space

The space shown in the figure is required in order to use this machine.

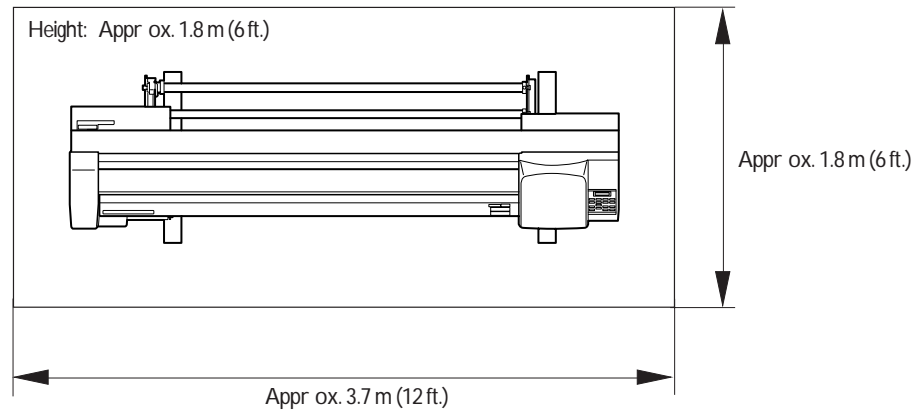

3. Assembling and Installing

Assemble the Stand

First assemble the stand, then mount the machine on top of the stand.

- ⚠ CAUTION** **Unpacking and installation must be carried out by four or more persons.**
Otherwise the machine or the stand may fall, resulting in injury.
- ⚠ CAUTION** **Use the joining bolts to secure the machine to the stand.**
Failure to do so may result in falling of the machine, leading to injury.
- ⚠ CAUTION** **Use care to avoid pinching the fingers when placing the machine on the stand.**
Failure to do so may result in injury.

Procedure

- 1** Attach the casters onto the stand leg.
Tighten the bolts securely. Loose bolts may cause the stand to wobble.

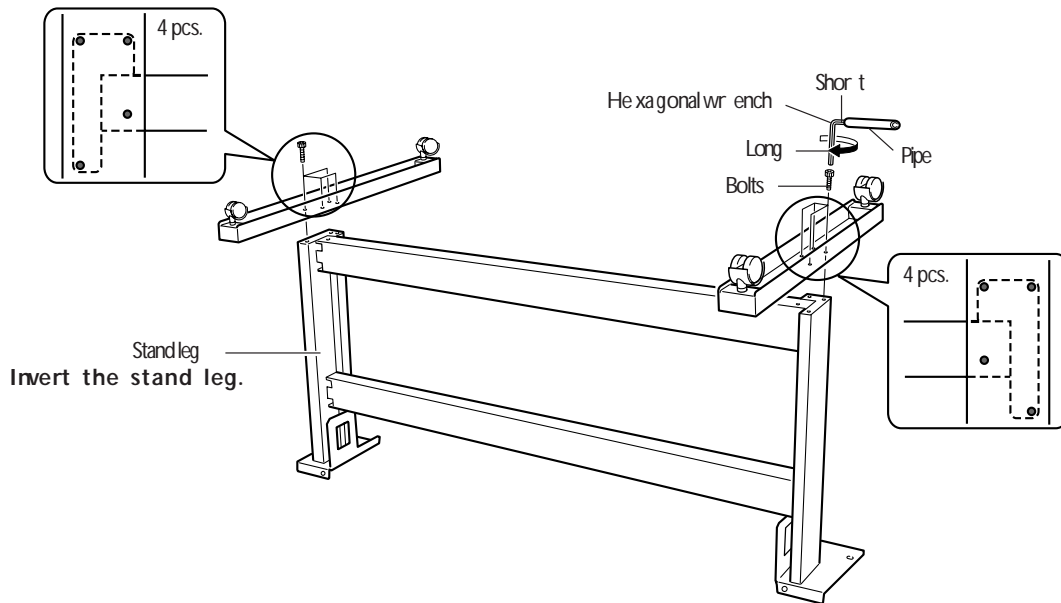

3. Assembling and Installing

- ② Set the stand upright, and place the machine on the stand.

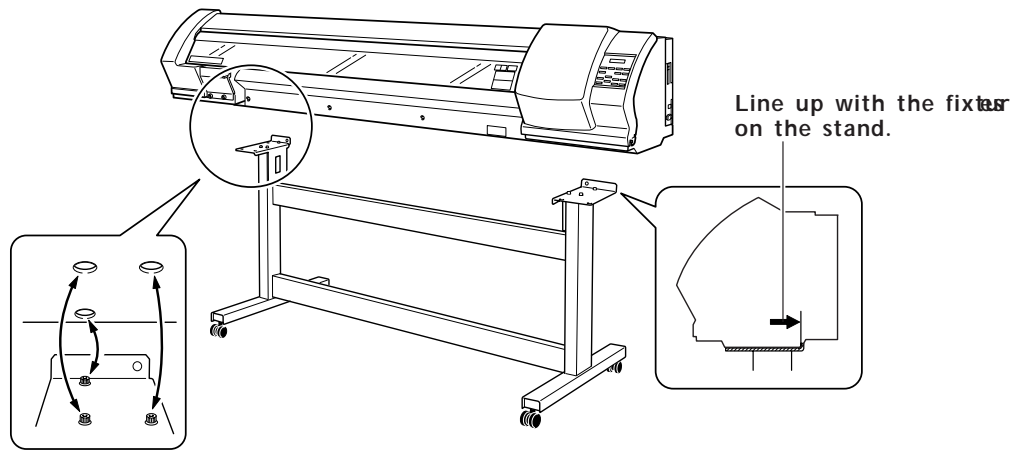

- ③ Use the bolts to secure the machine to the stand.
Tighten the bolts securely. Loose bolts may cause the stand to wobble.

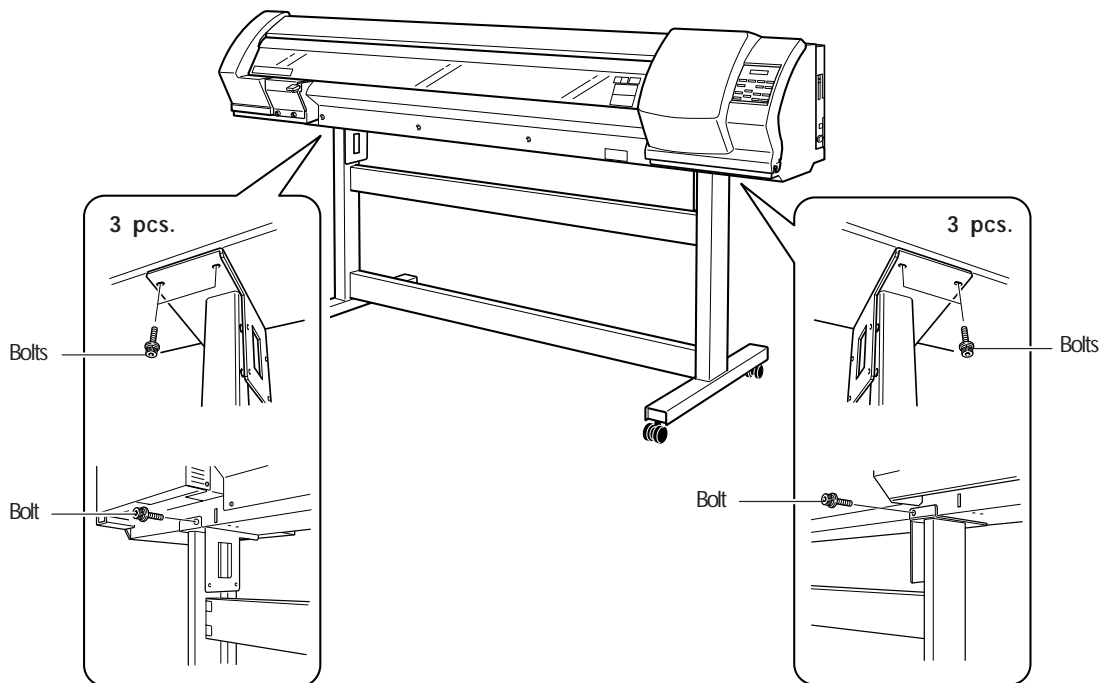

Install the Arms and Shafts

Procedure

- 1 Attach the arms.

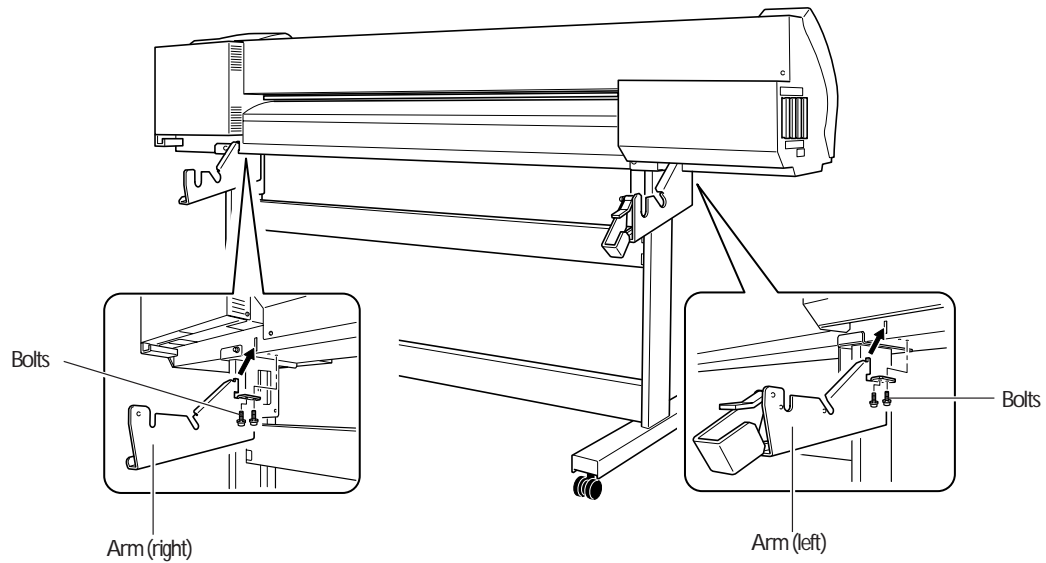

- 2 Attach the stoppers onto both ends of the shafts.

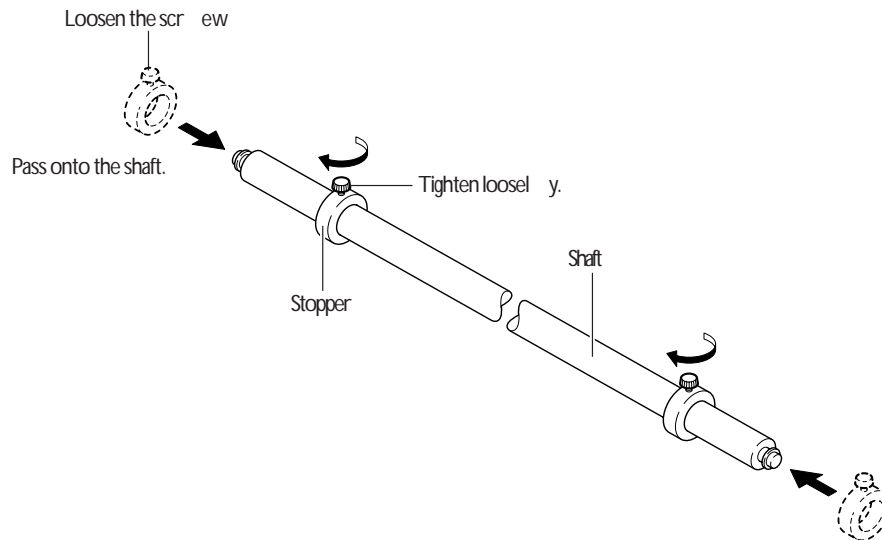

3. Assembling and Installing

- 3 Attach the two shafts to the arms.

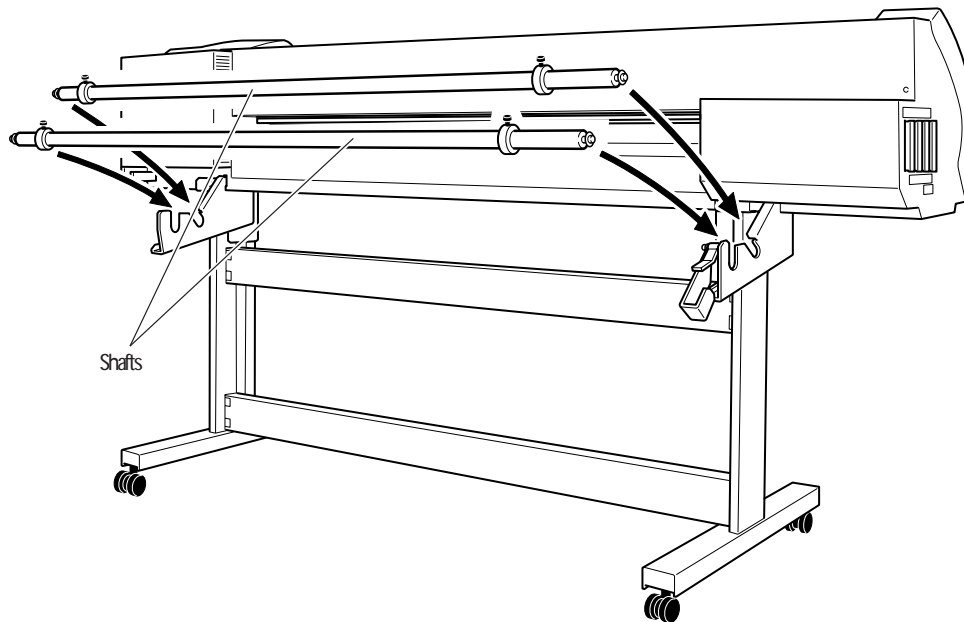

- 4 Engage the brake.

Using the machine with the brake disengaged may result in unstable media feed, leading to poor image quality.

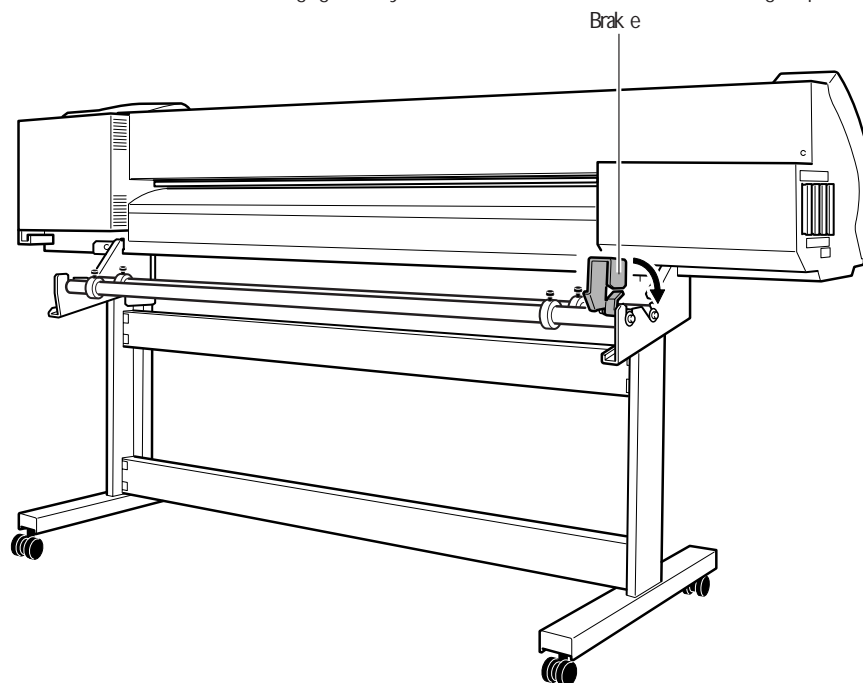

Install the Drain Bottle

1 Remove the bottom plug.

Use caution, because discharged fluid used in inspection may remain.

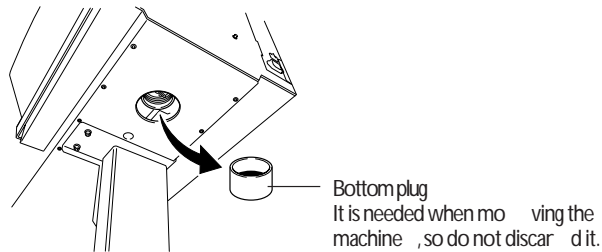

2 Install the drain bottle.

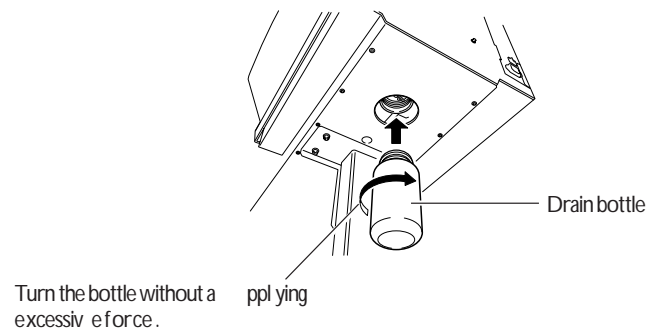

Leave the drain bottle attached at all times.

Remove it only when moving the machine or disposing of collected ink.

Remove the Packing Materials

Tape and packing materials are attached to the machine to protect it from vibration during transportation. When installation is complete, remove these.

- Remove all packing materials. Any that remain may cause faulty operation or breakdown when the power is switched on.
- Store the packing materials carefully, because they are needed again when transporting the machine for relocation or the like.

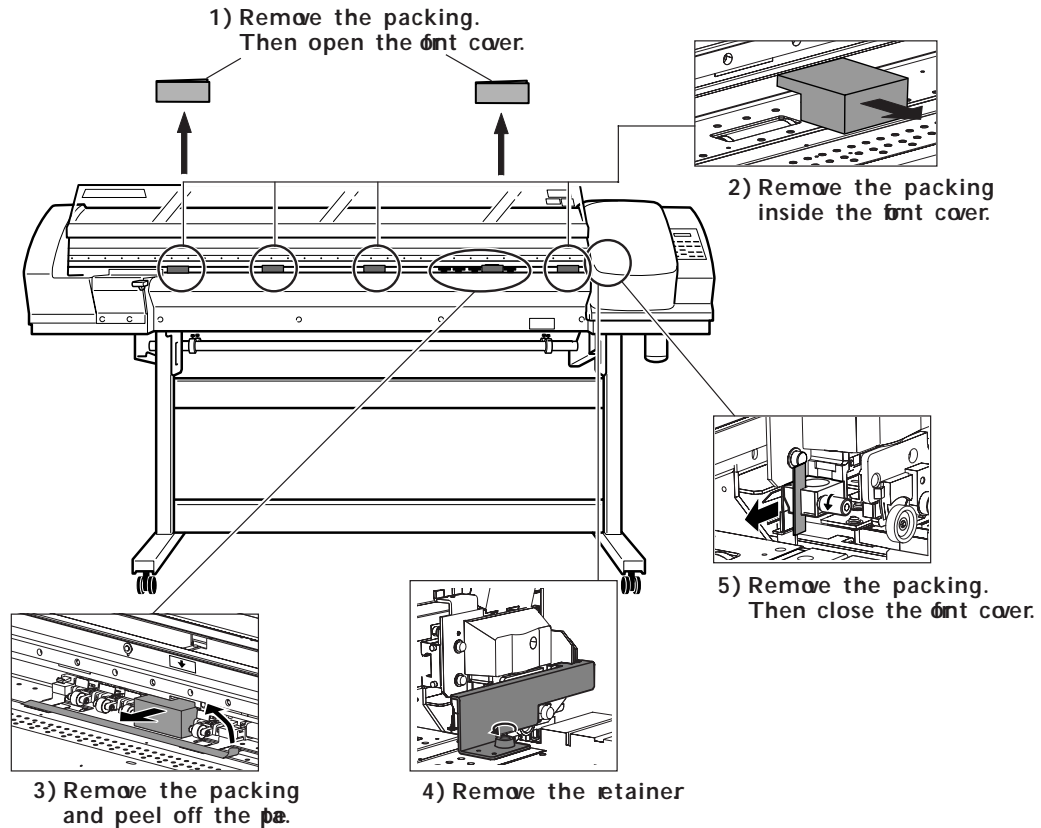

You can attach the removed packing material at the location shown in the figure for storage.

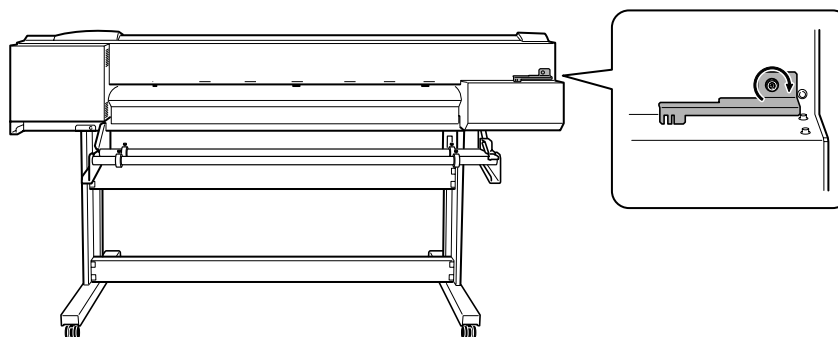

4. Connect the Cables

Set the Voltage Switches

⚠ WARNING Before switching on the power, set the voltage switches to match the voltage of the region where the unit is used. When set incorrectly, the machine may fail to operate normally. The temperature of the print heater and dryer may rise to undue levels, which may result in fire, or the temperature may fail to rise at the correct speed.

Set the two voltage switches to match the voltage of the region where the machine is used.

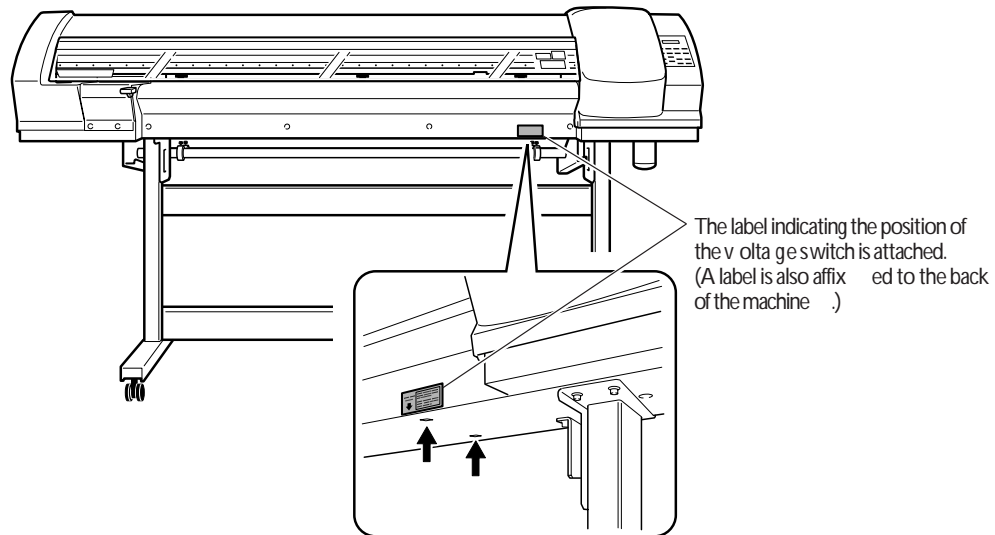

How to Make the Settings for the Voltage Switches

If your region is 100 to 120 V, move the switch to the location where [115 V] is visible. If your region is 220 to 240 V, move the switch to the location where [230 V] is visible. The default setting is [230V].

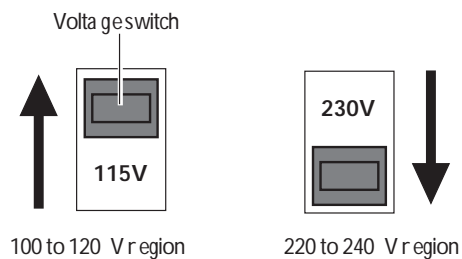

Connect the Cables

⚠WARNING Do not use with any electrical power supply that does not meet the ratings displayed on the unit.
Use with any other power supply may lead to fire or electrocution.

⚠WARNING Ground the unit with the ground wire.
Failure to do so may result in risk of electrocution in the event of a mechanical problem.

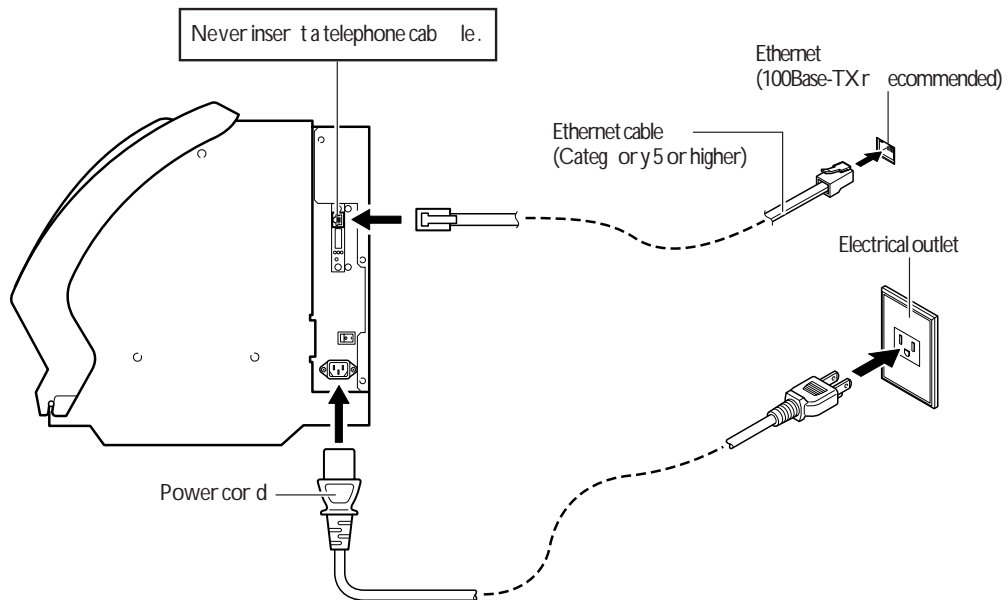

Important Notes on the Power Cord

This machine carries a high current of a maximum of approximately 9 amperes. Failure to observe the following requirements in particular may lead to an accident that could not occur with low-power equipment.

- ⚠ WARNING** **Never damage the power cord or pull it with force.**
Doing so may tear the cord's insulation, causing an electrical short and resulting in electrical shock, electrocution, or fire.
- ⚠ WARNING** **Never place any object on the power cord, bend the power cord using excessive force, or allow the power cord to become deformed.**
If it becomes deformed, the deformed location may grow hot and cause fire.
- ⚠ WARNING** **Never use the machine with the power cord bound into a bundle or roll.**
If the cord is in a bundle or roll, it may grow hot and cause fire.
- ⚠ WARNING** **Never use any power cord other than the power cord included with the machine. Also, never use a power strip or extension cord.**
The power strip or extension cord may grow hot and cause fire.
- ⚠ WARNING** **Do not use with a damaged power cord or plug, or with a loose electrical outlet.**
Doing so may lead to fire, electrical shock, or electrocution.

5. Install the Ink Cartridges

Filling with Ink for the First Time

Special procedures are required when installing ink cartridges for the first time. These are required only once, when installing ink cartridges for the first time after shipment from the factory.

You first clean the print heads using cleaning fluid, then fill with the inks of the various colors. This operation requires two SOL INK cleaning cartridges.

Never under any circumstances use anything other than the specified type of ink or cleaning fluid.

Installing the Ink Cartridges

Be sure to follow the on-screen instructions for insertion and removal.

- Keep the labeled side face up.
- Insert and remove slowly, one at a time.
- Insert firmly, as far as it will go.

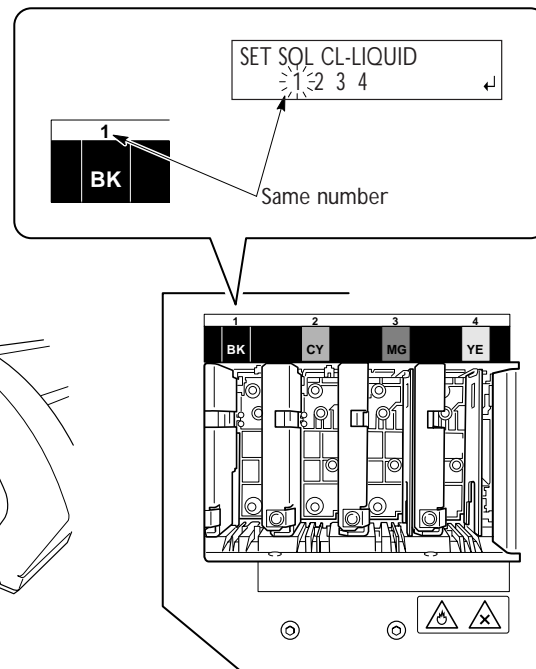
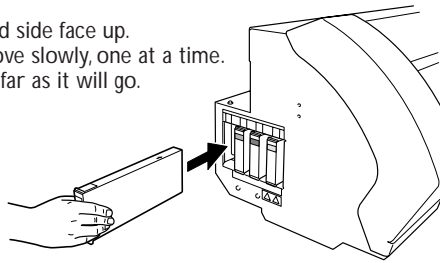

During cleaning, you insert and remove cartridges several times. The on-screen messages indicate which to insert and remove, and when to insert and remove them.

Insert each color ink cartridge into the slot labeled with the matching color. The cleaning cartridges are not differentiated by color.

⚠ CAUTION

Never insert your hand or fingers into the opening of the front cover. The print heads move at high speed inside the cover. Contact may cause injury.

⚠ WARNING

If you're using a model that uses ECO-SOL INK, never place ink, cleaning liquid, or discharged fluid in any of the following locations.

- Near open flame
 - In a hot location, such as near a heater or on the machine's platen or apron
 - Near bleach, chemicals, explosives, or the like
- Doing so may cause fire.

1. Switch on the power and make the initial settings.

1

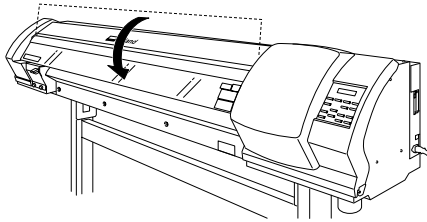

Close the front cover.

2

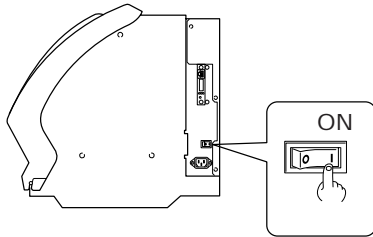

Switch on the main power switch.

3

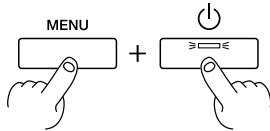

Hold down **MENU** and press the sub power switch.

4



Use **▲** **▼** to select the language you want.
Press **ENTER** .

5



Use **▲** **▼** to select the unit of measurement you want (for length).
Press **ENTER** .

6

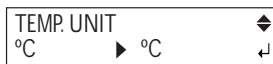

Use **▲** **▼** to select the unit of measurement you want (for temperature).
Press **ENTER** .

7



Make sure the two voltage switches are set correctly.
Press **ENTER** .

2. Clean the heads using the cleaning cartridges.

①

| |
|-----------------|
| SELECT INK TYPE |
| ECO-SOL 4 COLOR |

 Make sure the ink type matches the ink cartridges.
Press **ENTER** .

②

| |
|----------------------|
| INSTALL DRAIN BOTTLE |
|----------------------|

 Make sure the drain bottle is installed.
Press **ENTER** .

③

| |
|-------------------|
| SET SOL CL-LIQUID |
| 1 2 |

 Insert cleaning cartridges into slots 1 and 2.

Flashing ↓

| |
|----------------|
| FILLING INK... |
|----------------|

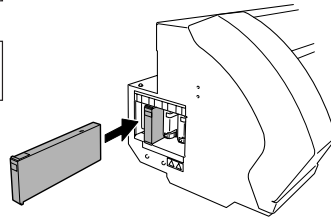

④

| |
|---------------|
| REMOVE SOL CL |
| 1 2 |

 ① Pull out the cleaning cartridges.

Flashing ↓

| |
|-------------------|
| SET SOL CL-LIQUID |
| 3 4 |

Flashing ↓

| |
|----------------|
| FILLING INK... |
|----------------|

② Insert the cleaning cartridges you pulled out into slots 3 and 4.

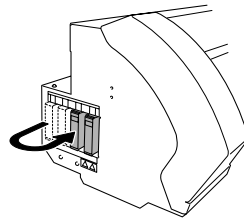

⑤

| |
|---------------|
| REMOVE SOL CL |
| 3 4 |

 Pull out the cleaning cartridges.

Flashing ↓

| |
|----------------|
| FILLING INK... |
|----------------|

⑥

| |
|--------------|
| SET SOL CRT. |
| 1 2 3 4 |

 When this screen appears, cleaning is finished.

Flashing

3. Insert the ink cartridges for the respective colors.

1

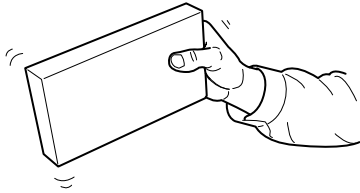

Before you insert the ink cartridge for each color, gently shake the cartridge.

2

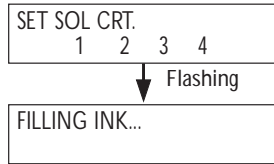

Insert the ink cartridge for each color.

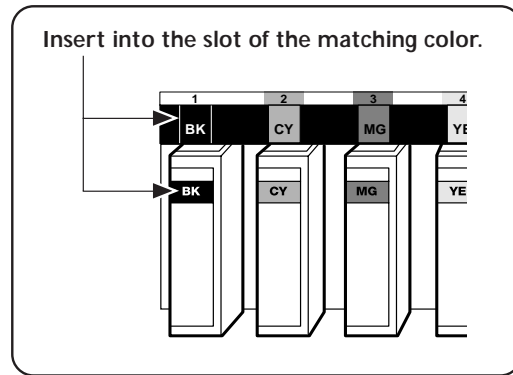
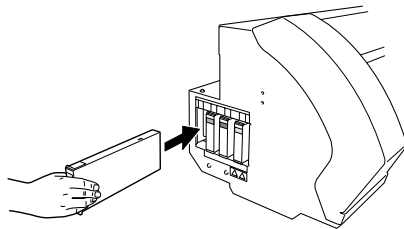

3



When the screen in the figure appears, ink filling ends.

6. Match the Machine to the Environment

⚠ CAUTION Never insert your hand or fingers into the opening of the front cover.
The print heads move at high speed inside the cover. Contact may cause injury.

The machine performs adjustment to optimize its state to the environment where it is used.

Procedure

- 1

| | |
|------------|---|
| MENU | ↕ |
| ENV. MATCH | ↕ |

 Press

| |
|------|
| MENU |
|------|

 .
Press

| |
|---|
| ▼ |
|---|

 several times.
Press

| |
|-------|
| ENTER |
|-------|

 .
- 2

| | |
|-----------------|---|
| ENV. MATCH | ↕ |
| SETUP COMPLETED | ↕ |

 When adjustment ends, then press

| |
|-------|
| ENTER |
|-------|

 .
- 3

| |
|-------------|
| SETUP SHEET |
|-------------|

 Press

| |
|------|
| MENU |
|------|

 to go back to the original screen.

7. Install the Blade

⚠ CAUTION Be sure to perform operations as specified by these instructions, and never touch any area not specified in the instructions. Sudden movement of the machine may cause injury.

⚠ CAUTION Never touch the tip of the blade with your fingers. Doing so may result in injury, and the cutting performance of the blade will be impaired.

1. Insert a blade into the blade holder.

1  Insert the pin into the blade holder.

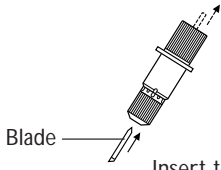
2  It snaps into place with an audible click. Insert the blade.

2. Enter the blade replacement mode.

1  Press **MENU** .
Press **▼** several times.
Press **ENTER** .

2  Preparation are complete when this screen appears.

3 Open the front cover.

3. Install the blade holder.

1

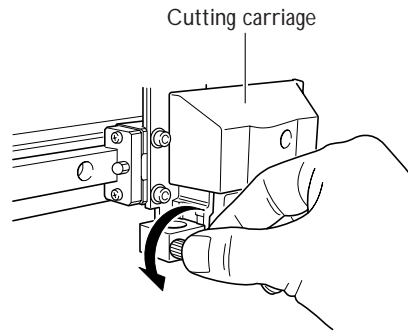

Loosen the screw shown in the figure.

2

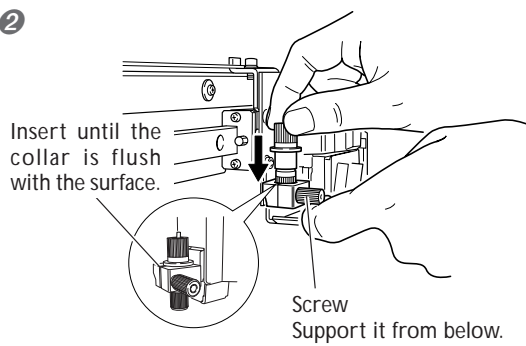

Support the screw from below and insert the blade holder.
If installed without supporting the screw in this way, cutting quality may become poor.

3

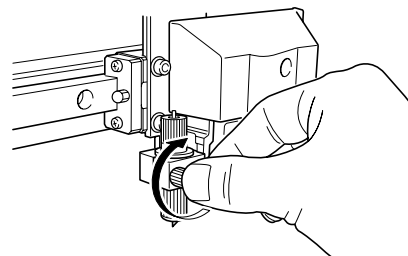

Tighten the screw.
Tug the blade holder upward to make sure it does not come loose.

4

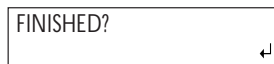

Close the front cover, then press **ENTER** .

Important Note on the Handling and Use of the Cutting Carriage

Leave the cutting-carriage screw loose when no blade holder is installed. Keeping the screw tightened causes the blade-holder insertion hole to gradually become smaller, making installation difficult.

8. When Not in Use for a Prolonged Period

Keep Performing Maintenance

Switch On the Power Once a Month

Switch on the sub power once a month. When you turn on the power, the machine automatically performs some operations such as those to keep the print heads from drying out. Allowing the machine to stand completely unused for a prolonged period may damage the print heads, so be sure to switch on the power to perform these automatic operations.

Keep at a Constant Temperature and Relative Humidity

Even when the machine is not in use, keep it at a temperature of 5 to 40°C (41 to 104°F) and a relative humidity of 20 to 80% (with no condensation). Temperatures that are too high may degrade the ink and cause malfunction. Temperatures that are too low may cause the ink to freeze and damage the heads.

Alarm Feature



PRESS THE POWER
KEY TO CLEAN ↗

This function is to remind you to switch on the sub power once a month when you're using ECO-SOL INK. When the machine remains unused for about one month, this screen appears and a warning beep sounds. If this screen appears, switch on the sub power. When maintenance operations finish, switch off the sub power.

This feature operates when the printer's main power is turned on. We recommend leaving on just the main power to the printer even when the machine is to remain out of use for a prolonged period.

Important Note on Draining Ink

This machine has features for draining internal ink and for performing washing using washing cartridges, but they should never be used except in special cases. When you're using ECO-SOL ink, allowing the machine to stand without ink for a prolonged period may damage the heads, even if internal washing is performed. Once ink has been filled, then as a rule the ink should never be drained.

9. When Moving the Unit

Procedures from Preparing to Move Through Reinstalling

To move the machine, you must completely drain all ink inside the machine and secure the print heads in place with retainers to protect them. Attempting to move the machine without first doing this may result in damage to internal components due to leaking ink or damage to the heads.

This operation requires four **UNUSED** SOL INK cleaning cartridges. Have these on hand before you start.

Important Notes on Moving

- > Be sure to use SOL INK cleaning cartridges. Use of any other type may result in breakdown.
- > Once the preparations for moving are complete, move the machine and fill it with ink with as little delay as possible. Allowing the machine to stand without ink may damage the heads.
- > When moving the machine, keep it at a temperature between 5 to 40°C (41 to 104°F) and at relative humidity between 20 to 80% (with no condensation). Failure to do so may result in breakdown.
- > Handle the machine with care when moving, keeping it level (not tilted at an angle) and preventing it from striking other objects.

1. Drain the ink and wash the interior.

1 MENU
INK CONTROL

Press **MENU** .
Press **▼** several times to select [INK CONTROL].

2 INK CONTROL
HEAD WASH

Press **▶** .
Press **▼** several times to select [HEAD WASH].
Press **ENTER** .

3 EMPTY
DRAIN BOTTLE

Discard the discharged ink in the drain bottle.
Attach the drain bottle and press **ENTER** .
Be sure to discard the discharged ink. For more information about how to dispose of discharged ink, refer to "User's Manual."

4 REMOVE SOL CRT.
1 2 3 4
Flashing

Pull out all the ink cartridges.
Ink discharge is performed over the course of several minutes.

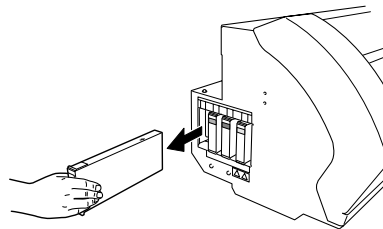

5

| |
|-------------------|
| SET SOL CL-LIQUID |
| 1 2 3 4 |
| Flashing |

When this screen appears, insert the four cleaning cartridges.

Thereafter, follow the on-screen instructions to insert and remove the cartridges several times.

Internal washing is performed over the course of several minutes. When the process ends, the sub power is switched off. Store the cleaning cartridges safely, because they will be needed again after you move the machine.

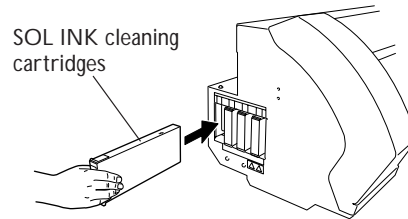

6 Turn off the main power switch.

2. Secure the print heads in place.

- 1 Remove the drain bottle and discard the discharged ink. Attach the bottom plug where the drain bottle was installed.
- 2 Detach the blade holder.
- 3 Raise the loading lever.
- 4 Secure the print heads in place using the retainer.
For information on how to secure in place, go to "3. Assembling and Installing" and refer to "Remove the Packing Materials."
- 5 Lower the roll media from the printer and detach the shafts.
If necessary, also detach the left and right arms and the stand.
The machine is now ready to be moved.

3. Immediately move the machine and fill it with ink.

- 1 Once the preparations are complete, move the machine with as little delay as possible.
- 2 Immediately reinstall the machine and fill with ink.
To reinstall and fill with ink, carry out "3. Assembling and Installing" through "7. Install the Blade." When filling with ink, you use the cleaning cartridges again.



26015499-R2

R2-040910