

# **Hi-Fi JET PRO II**

High Fidelity inkjet printer by Roland DG Corporation

---

---

## **FJ-540**

### **USER'S MANUAL**

---

---

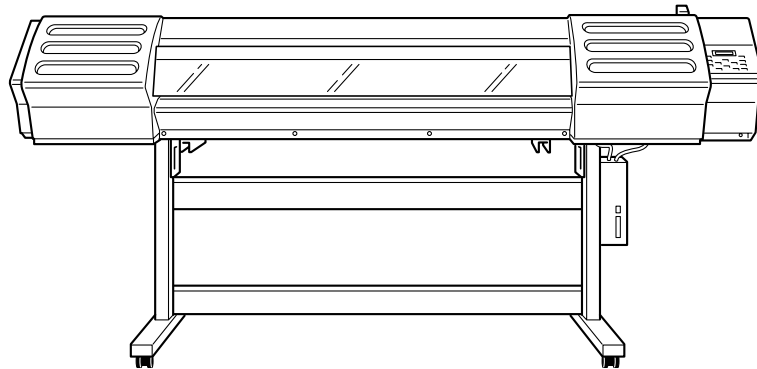

Thank you very much for purchasing the product.

- To ensure correct and safe usage with a full understanding of this product's performance, please be sure to read through this manual completely and store it in a safe location.
- Unauthorized copying or transferral, in whole or in part, of this manual is prohibited.
- The contents of this operation manual and the specifications of this product are subject to change without notice.
- The operation manual and the product have been prepared and tested as much as possible. If you find any misprint or error, please inform us.
- Roland DG Corp. assumes no responsibility for any direct or indirect loss or damage which may occur through use of this product, regardless of any failure to perform on the part of this product.
- Roland DG Corp. assumes no responsibility for any direct or indirect loss or damage which may occur with respect to any article made using this product.

**For the USA**

**FEDERAL COMMUNICATIONS COMMISSION  
RADIO FREQUENCY INTERFERENCE  
STATEMENT**

This equipment has been tested and found to comply with the limits for a Class A digital device, pursuant to Part 15 of the FCC Rules.

These limits are designed to provide reasonable protection against harmful interference when the equipment is operated in a commercial environment.

This equipment generates, uses, and can radiate radio frequency energy and, if not installed and used in accordance with the instruction manual, may cause harmful interference to radio communications.

Operation of this equipment in a residential area is likely to cause harmful interference in which case the user will be required to correct the interference at his own expense.

Unauthorized changes or modification to this system can void the users authority to operate this equipment.

The I/O cables between this equipment and the computing device must be shielded.

**NOTICE**

**Grounding Instructions**

Do not modify the plug provided - if it will not fit the outlet, have the proper outlet installed by a qualified electrician.

Check with qualified electrician or service personnel if the grounding instructions are not completely understood, or if in doubt as to whether the tool is properly grounded.

Use only 3-wire extension cords that have 3-prong grounding plugs and 3-pole receptacles that accept the tool's plug.

Repair or replace damaged or worn out cord immediately.

**For Canada**

**CLASS A NOTICE**

This Class A digital apparatus meets all requirements of the Canadian Interference-Causing Equipment Regulations.

**CLASSE A AVIS**

Cet appareil numérique de la classe A respecte toutes les exigences du Règlement sur le matériel brouilleur du Canada.



**ROLAND DG CORPORATION**

1-6-4 Shinmiyakoda, Hamamatsu-shi, Shizuoka-ken, JAPAN 431-2103

MODEL NAME : See the MODEL given on the rating plate.

RELEVANT DIRECTIVE : EC LOW VOLTAGE DIRECTIVE (73/23/EEC)

EC ELECTROMAGNETIC COMPATIBILITY DIRECTIVE (89/336/EEC)

**WARNING**

This is a Class A product. In a domestic environment this product may cause radio interference in which case the user may be required to take adequate measures.

# Contents

<b>Contents</b> .....	<b>1</b>
<b>Features of the FJ-540</b> .....	<b>4</b>
<b>To Ensure Safe Use</b> .....	<b>5</b>
About the Labels Affixed to the Unit .....	8
<b>Pour utiliser en toute sécurité</b> .....	<b>9</b>
À propos des étiquettes collées sur l'appareil .....	12
<b>1. Getting Started</b> .....	<b>13</b>
1-1 Checking Accessories .....	14
1-2 Part Names .....	15
1-3 Assembling and Installing .....	17
Installation Environment .....	17
Step 1: Assemble the Stand .....	18
Step 2: Install the Included Items .....	20
Step 3: Install the Drain Bottle .....	21
Step 4: Remove the Protective Media .....	23
1-4 Connecting the Cables .....	24
Connecting the Power Cord .....	24
Connecting to the Computer .....	25
1-5 Switching On the Power for the First Time .....	27
Step 1: Install Ink Cartridges .....	27
Step 2: Perform Ink Filling .....	28
<b>2. Basic Operation</b> .....	<b>29</b>
2-1 Switching the Power On and Off .....	30
Switching On the Power .....	30
Switching Off the Power at the End of the Day .....	31
2-2 Loading Media .....	32
Loading Roll Media .....	32
Loading Sheet Media .....	35
When Loading Thick Media .....	36
When Loading Media That Warps Easily .....	37
Separating the Media .....	38
Removing the Media .....	38
2-3 Printing .....	39
To Perform Printing .....	39
Performing a Printing Test .....	40
Downloading Printing Data .....	40

<b>3. A Wide Variety of Operations .....</b>	<b>41</b>
3-1 Replacing the Ink Cartridges .....	42
Care and Handling of Ink Cartridges .....	42
Replacing with New Ink Cartridges .....	43
If ink runs out during printing .....	44
3-2 Checking the Remaining Ink Level .....	45
3-3 Setting the Location Where Printing Starts .....	46
Setting the Start Location .....	46
Specifying a Location in the Feed Direction .....	47
Specifying a Location in the Scan Direction .....	48
3-4 Setting the Margins .....	49
Setting the Margins in the Feed Direction .....	49
Setting the Margins in the Scan Direction .....	50
3-5 Using Transparent Media .....	52
3-6 Making Corrections for Printing .....	53
Feed Correction .....	53
Bidirectional Correction .....	54
3-7 Stopping Printing Operations .....	57
Stopping Printing Operations .....	57
Pausing Printing Operations .....	57
3-8 Changing the Type of Ink .....	58
3-9 When Not in Use for a Prolonged Period .....	60
<b>4. Maintenance .....</b>	<b>61</b>
4-1 Cleaning the Printing Heads .....	62
Cleaning the Printing Heads .....	62
If Drop-out Persists Even After Carrying Out Cleaning Several Times .....	63
If Performing POWERFUL Cleaning Several Times Does Not Correct the Drop-out Problem .....	63
4-2 Cleaning Using the Cleaning Kit .....	64
4-3 Replacing the Wiper .....	67
4-4 Other Cleaning Tasks .....	68
4-5 Disposing of Discharged Ink .....	69
4-6 How to Replace the Separating Knife .....	70
4-7 When Moving the Unit .....	71

<b>5. Menus and Keys .....</b>	<b>73</b>
5-1 Display Menus Flowchart .....	74
5-2 Description of Menus .....	78
5-3 Description of Keys .....	81
<b>6. What to Do If... .....</b>	<b>83</b>
6-1 What to Do If... .....	84
The machine doesn't run .....	84
Clean, attractive printing is impossible .....	85
The media becomes jammed .....	88
What to Do If the Printing Carriage Does Not Operate .....	89
6-2 What to Do If an Error Message Appears .....	91
<b>7. Appendix .....</b>	<b>93</b>
7-1 Specifications .....	94
Main unit Specification .....	94
Interface Specifications .....	95
Network Interface Specifications .....	95
7-2 Media Conditions .....	96
Usable Media .....	96
Loadable Media Widths .....	96
7-3 Printing Area .....	97
7-4 The Media-cutoff Location During Continuous Printing .....	98

SelectColor™ is trademark of Roland DG Corporation.  
 Other company names and product name are trademarks or registered trademarks of their respective holders.

# Features of the FJ-540

---

## **What Is the FJ-540?**

The FJ-540 is a large-format printer combining high speed with high print quality. It supports a wide variety of media types, as well as pigment and dye-based inks.

## **Built-in Print Server**



This machine has a built-in print server (Roland-PrintServer) as a network interface. When you use the print server, you can send printing data to the machine from anywhere on the network.

## **Includes a Software Raster Image Processor (RIP)**



Roland SelectColor, which is included with the machine, lets you use your computer to perform raster image processing for printing data such as PostScript files exported from a program and output the data to the machine.

# To Ensure Safe Use

## About ⚠️ WARNING and ⚠️ CAUTION Notices

 <b>WARNING</b>	Used for instructions intended to alert the user to the risk of death or severe injury should the unit be used improperly.
 <b>CAUTION</b>	Used for instructions intended to alert the user to the risk of injury or media damage should the unit be used improperly. * Media damage refers to damage or other adverse effects caused with respect to the home and all its furnishings, as well to domestic animals or pets.

## About the Symbols

	The ⚠️ symbol alerts the user to important instructions or warnings. The specific meaning of the symbol is determined by the design contained within the triangle. The symbol at left means "danger of electrocution."
	The ⚡ symbol alerts the user to items that must never be carried out (are forbidden). The specific thing that must not be done is indicated by the design contained within the circle. The symbol at left means the unit must never be disassembled.
	The ● symbol alerts the user to things that must be carried out. The specific thing that must be done is indicated by the design contained within the circle. The symbol at left means the power-cord plug must be unplugged from the outlet.

## ⚠️ WARNING



### **Do not disassemble, repair, or modify.**

Doing so may lead to fire or abnormal operation resulting in injury.



### **Ground the unit with the ground wire.**

Failure to do so may result in risk of electrical shock in the even of a mechanical problem.



### **Use only with a power supply of the same rating as indicated on the unit.**

Use with any other power supply may lead to fire or electrocution.



### **Do not use while in an abnormal state (i.e., emitting smoke, burning odor, unusual noise, or the like).**

Doing so may result in fire or electrical shock. Immediately switch off first the sub power, then the main power, unplug the power cord from the electrical outlet, and contact your authorized Roland DG Corp. dealer or service center.



### **Use only with the power cord included with this product.**

Use with other than the included power cord may lead to fire or electrocution.

## CAUTION



**Do not use with a damaged power cord or plug, or with a loose electrical outlet.**

Use with any other power supply may lead to fire or electrocution.

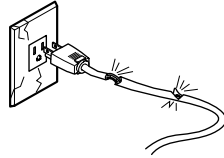

**Do not injure or modify the electrical power cord, nor subject it to excessive bends, twists, pulls, binding, or pinching, nor place any object of weight on it.**

Doing so may damage the electrical power cord, leading to electrocution or fire.

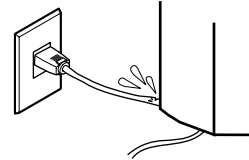

**When not in use for extended periods, unplug the power cord from the electrical outlet.**

Failure to do so may result in danger of shock, electrocution, or fire due to deterioration of the electrical insulation.

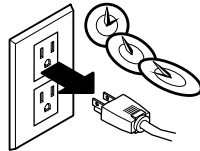

**When unplugging the electrical power cord from the power outlet, grasp the plug, not the cord.**

Unplugging by pulling the cord may damage it, leading to fire or electrocution.

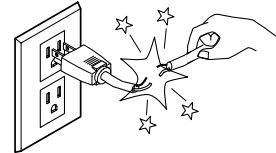

**Do not attempt to unplug the power cord with wet hands.**

Doing so may result in electrical shock.

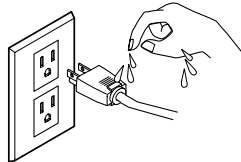

**Do not allow liquids, metal objects or flammables inside the machine.**

Such medias can cause fire.



**Unpacking, and installation must be carried out by four or more persons.**

Otherwise the machine or the stand may fall, resulting in injury.

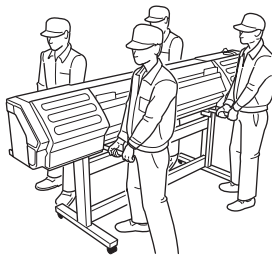

**Use the joining screws to secure the unit to the stand.**

Failure to do so may result in falling of the unit, leading to injury.

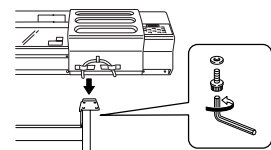

**Install in a level and stable location.**

Otherwise the unit may tip over and cause injury.

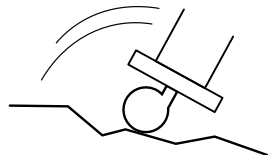

**Use care to avoid pinching the fingers when placing the unit on the stand.**

Doing so may result in injury.

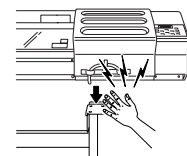



## ⚠ CAUTION



**Be sure to install the media guide when loading roll media.**

Otherwise the roll may fall and cause injury.

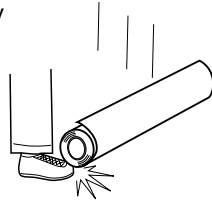

**Load roll media at the proper position.**

Otherwise the roll may fall, resulting in injury.

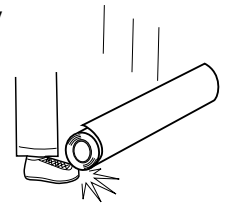

**Release the caster locks for the stand before attempting to move.**

Otherwise the unit may tip over and cause injury.

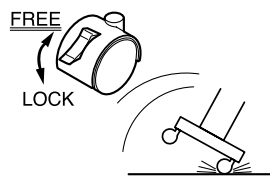

**Do not touch the tip of the separating knife with your fingers.**

Doing so may result in injury.



**Do not touch the control panel while head cleaning or other cleaning is in progress.**

The printing carriage may move and cause injury.



**Do not place hands within the space to the front of the unit while in operation.**

Doing so may result in injury.

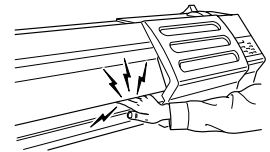

**Before switching on the power, be sure to install the drain bottle.**

Otherwise discharged fluid may leak from the machine.



**If ink contacts the eyes, flush immediately with water.**



**Store ink cartridges out of the reach of children.**

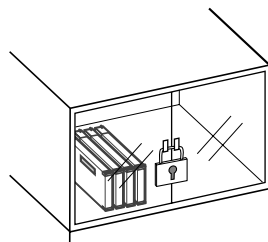

# About the Labels Affixed to the Unit

These labels are affixed to the body of this product.  
The following figure describes the location and content of these messages.

## Front

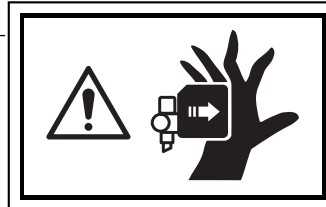
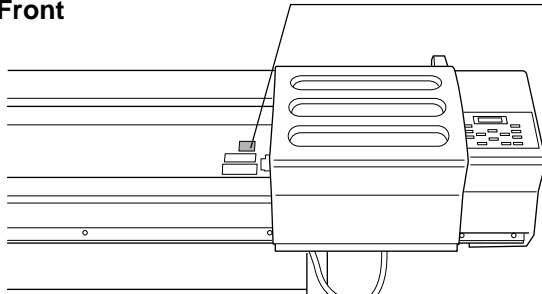

Do not place hands within the space to the front of the unit while in operation.

## Rear

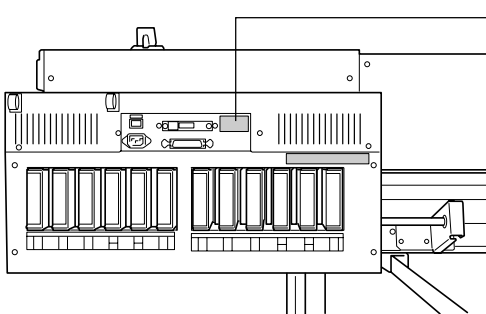

Rating label  
Use a rated power supply.

## Internal cover

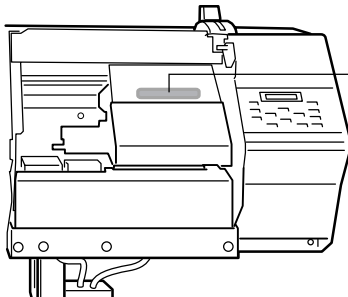

CAUTION : Read all Warnings and Procedures in the "User's MANUAL" before performing any cleaning.

## Ink cartridge

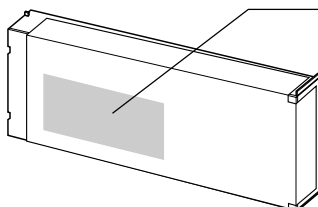

Do not dismantle the cartridge.  
Keep out of reach of children.  
Do not store the cartridge in high or freezing temperatures.

In addition to the **⚠ WARNING** and **⚠ CAUTION** symbols, the symbols shown below are also used





**Notice** : Indicates information to prevent machine breakdown or malfunction and ensure correct use.









**Point** : Indicates a handy tip or advice regarding use.

# Pour utiliser en toute sécurité

## Avis sur les avertissements

 <b>ATTENTION</b>	Utilisé pour avertir l'utilisateur d'un risque de décès ou de blessure grave en cas de mauvaise utilisation de l'appareil.
 <b>PRUDENCE</b>	Utilisé pour avertir l'utilisateur d'un risque de blessure ou de dommage matériel en cas de mauvaise utilisation de l'appareil. * Par dommage matériel, il est entendu dommage ou tout autre effet indésirable sur la maison, tous les meubles et même les animaux domestiques.

## À propos des symboles

	Le symbole  attire l'attention de l'utilisateur sur les instructions importantes ou les avertissements. Le sens précis du symbole est déterminé par le dessin à l'intérieur du triangle. Le symbole à gauche signifie "danger d'électrocution".
	Le symbole  avertit l'utilisateur de ce qu'il ne doit pas faire, ce qui est interdit. La chose spécifique à ne pas faire est indiquée par le dessin à l'intérieur du cercle. Le symbole à gauche signifie que l'appareil ne doit jamais être démonté.
	Le symbole  prévient l'utilisateur sur ce qu'il doit faire. La chose spécifique à faire est indiquée par le dessin à l'intérieur du cercle. Le symbole à gauche signifie que le fil électrique doit être débranché de la prise.

## **ATTENTION**



### **Ne pas démonter, réparer ou modifier.**

Le non-respect de cette consigne pourrait causer un incendie ou provoquer des opérations anormales entraînant des blessures.



### **Mettre l'appareil à la masse avec une prise de terre.**

Le non-respect de cette consigne pourrait entraîner des décharges électriques en cas de problème mécanique.



### **Utiliser seulement avec une alimentation de mêmes caractéristiques électriques que celles indiquées sur l'appareil.**

Une négligence à ce niveau pourrait provoquer un incendie ou une électrocution.



### **Ne pas utiliser si l'appareil est dans un état anormal (c'est-à-dire s'il y a émission de fumée, odeur de brûlé, bruit inhabituel etc.).**

Le non-respect de cette consigne pourrait provoquer un incendie ou des décharges électriques.

Couper immédiatement l'alimentation secondaire et ensuite l'alimentation principale. Débranchez le fil électrique et contacter votre revendeur ou votre centre de service de la société Roland DG autorisé.



### **Utiliser l'appareil uniquement avec le fil électrique fourni.**

Utiliser l'appareil avec un autre fil risque de provoquer un incendie ou une électrocution.

## PRUDENCE



**Ne pas utiliser avec une fiche ou un fil électrique endommagé ou avec une prise mal fixée.**

Une négligence à ce niveau pourrait provoquer un incendie ou une électrocution.

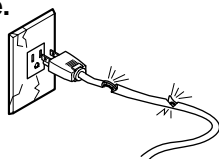

**Ne pas endommager ou modifier le fil électrique. Ne pas le plier, le tordre, l'étirer, l'attacher ou le serrer de façon excessive. Ne pas mettre d'objet ou de poids dessus.**

Une négligence à ce niveau pourrait endommager le fil électrique ce qui risquerait de provoquer une électrocution ou un incendie.

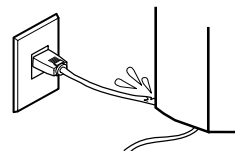

**Débrancher le fil lorsque l'appareil reste inutilisé pendant une longue période.**

Une négligence à ce niveau pourrait provoquer des décharges électriques, une électrocution ou un incendie dû à une détérioration de l'isolation électrique.

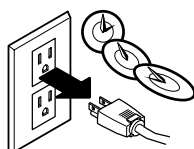

**Saisir la fiche et non le fil électrique lorsque vous débranchez.**

Débrancher en tirant sur le fil pourrait l'endommager et risquer de provoquer un incendie ou une électrocution.

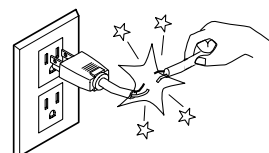

**Ne pas essayer de débrancher le fil avec des mains mouillées.**

Une négligence à ce niveau pourrait provoquer des décharges électriques.

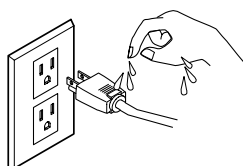

**Ne pas introduire de liquide, d'objet métallique ou inflammable dans l'appareil.**

Ce genre de matériel peut provoquer un incendie.



**Le déballage, l'installation et le déplacement de l'appareil doivent être effectués par quatre personnes ou plus.**

Le non-respect de cette consigne pourrait causer des défauts dans l'appareil entraînant des blessures.

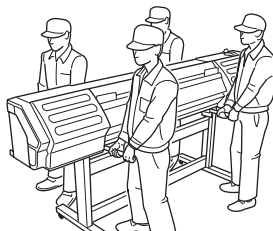

**Utiliser les vis fournies pour bien fixer l'appareil sur le support.**

Le non-respect de cette consigne pourrait causer des défauts dans l'appareil entraînant des blessures.

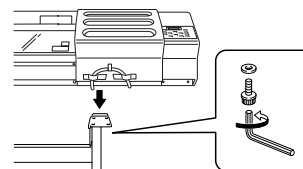

**Installer dans un endroit stable et de niveau.**

Sinon l'appareil pourrait se renverser et provoquer des blessures.

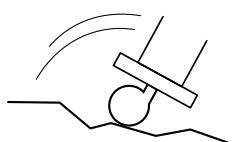

**Manipuler avec précaution pour éviter de se coincer les doigts lors de l'installation de l'appareil sur le support.**

Une négligence à ce niveau pourrait provoquer des blessures.

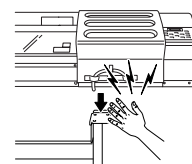

## PRUDENCE



**Le rouleau doit être placé quand la barre est en position adéquate.**

Une négligence à ce niveau pourrait provoquer la chute du rouleau et causer des blessures.

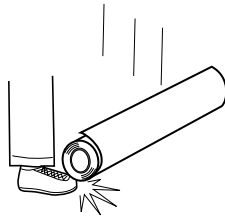

**Ne pas oublier d'installer le guide de média quand un rouleau est chargé.**

Le rouleur peut tomber et causer des blessures.

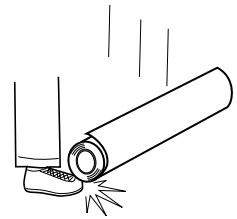

**Débloquer le mécanisme d'arrêt des roulettes du support avant de le déplacer.**

Sinon l'appareil pourrait se renverser et provoquer des blessures.

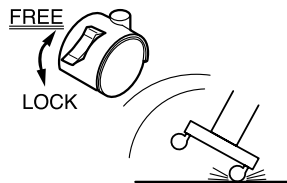

**Ne pas toucher le bout de la lame séparatrice avec les doigts.**

Une négligence à ce niveau pourrait provoquer des blessures.

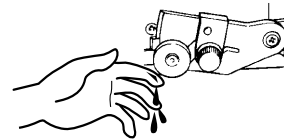

**Ne pas toucher le panneau de commande pendant le nettoyage des têtes ou d'autres pièces.**

Le chariot d'impression peut bouger et causer des blessures.



**Ne pas mettre les mains dans l'espace du devant quand l'appareil est en marche.**

Une négligence à ce niveau pourrait provoquer des blessures.

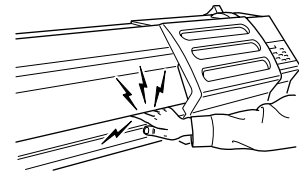

**Avant de mettre la machine sous tension, installer la bouteille de vidange, sinon du liquide peut fuir de la machine.**



**Si de l'encre entre en contact avec les yeux, rincer immédiatement à l'eau.**



**Ranger les cartouches d'encre hors de portée des enfants.**

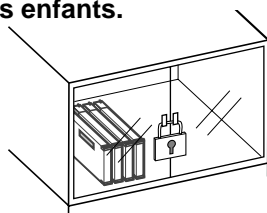

# À propos des étiquettes collées sur l'appareil

Ces étiquettes sont collées à l'extérieur de l'appareil.  
Les dessins suivants indiquent l'endroit et le contenu des messages.

## Avant

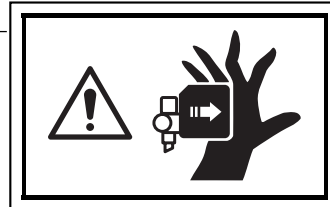
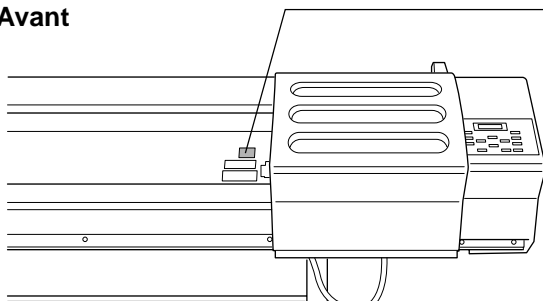

Ne pas mettre les mains dans l'espace devant l'élément quand celui-ci est en marche.

## Arrière

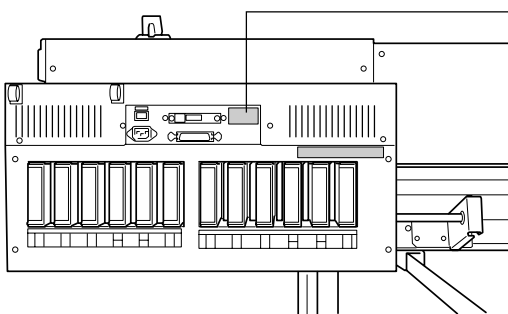

Étiquette des caractéristiques électriques  
Utiliser l'alimentation appropriée

## Couvercle interne

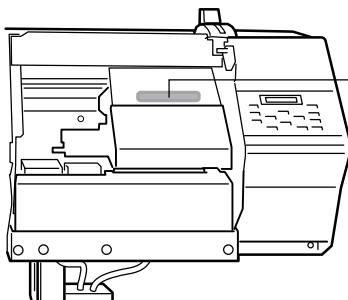

CAUTION : Read all Warnings and Procedures in the "User's MANUAL" before performing any cleaning.

Lire tous les avertissements et toutes les procédures dans le "Mode d'emploi" avant le nettoyage.

## la cartouche d'encre

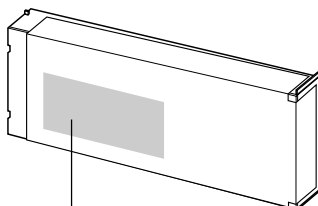

Ne pas démonter la cartouche.  
Conserver hors de la portée des enfants.  
Ne pas emmagasiner à des températures hautes ou basses.

# ***1. Getting Started***

---

This section describes what to do when you first open the packing carton, including installing the machine and connecting it to a computer.

# 1-1 Checking Accessories

The following items are packed together with the unit. Make sure they are all present and accounted for.

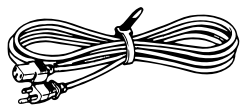

Power cord : 1

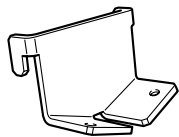

Stay (Right) : 1

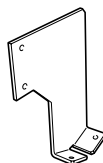

Stay (Left) : 1

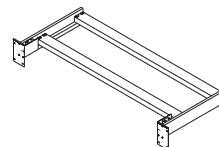

Stand leg: 1

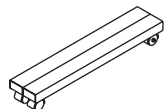

Casters : 2

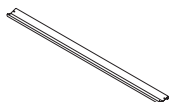

Media guide : 1

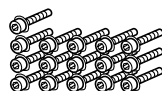

Bolts (Large) : 16



Bolts (Small) : 14



Washers: 6

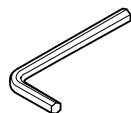

Hexagonal wrench : 1

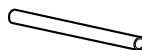

Pipe : 1

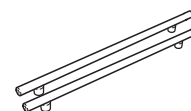

Transport bars : 2

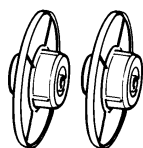

Media flanges : 2

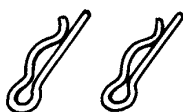

Flange retaining pins : 2



Drain bottle : 1

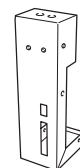

Bottle stand : 1

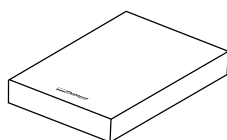

Roland SelectColor™ : 1

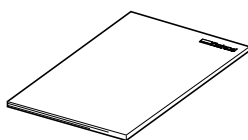

User's manual : 1

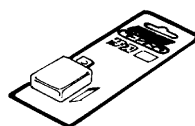

Replacement blade for separating knife : 1



Roland-PrintServer CD-ROM : 1

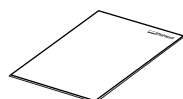

Roland PrintServer Network Settings Guide : 1

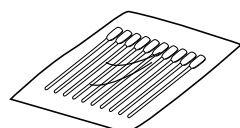

Cleaning kit : 1



Cleaning sticks : 10



Tweezers : 1

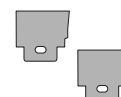

Wipers : 2



# 1-2 Part Names

## Front View

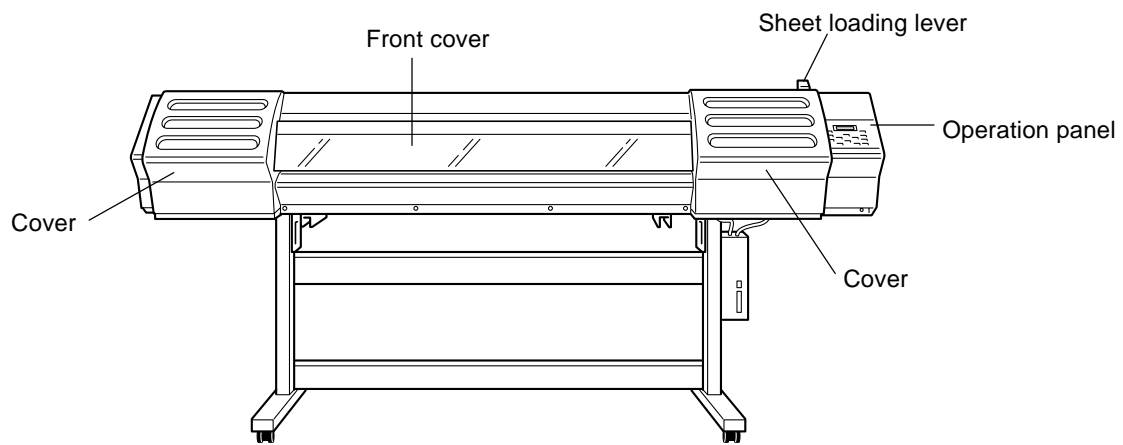

## Rear View

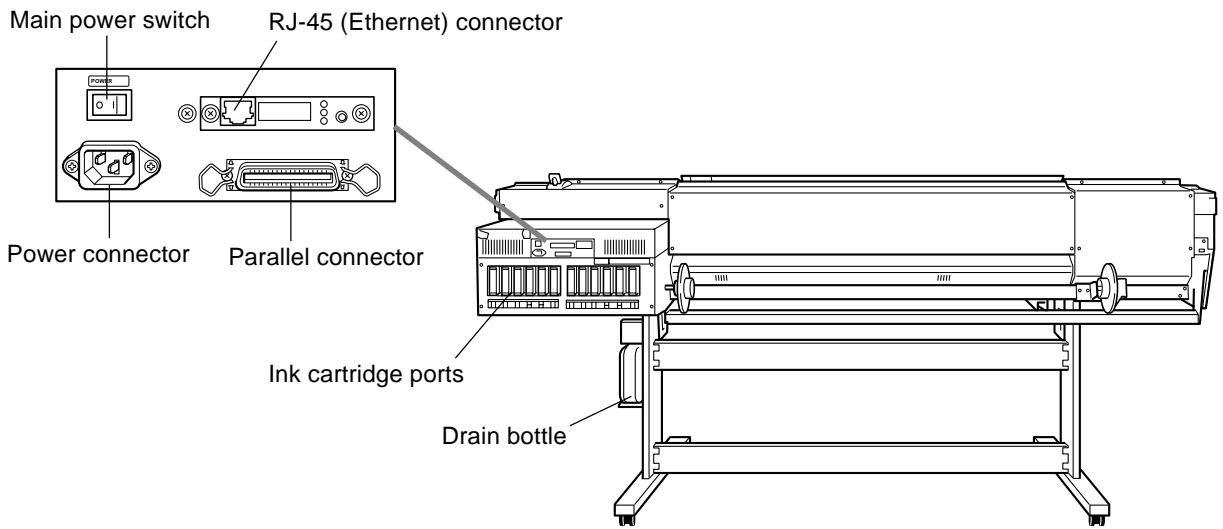

### Inside the Front Cover

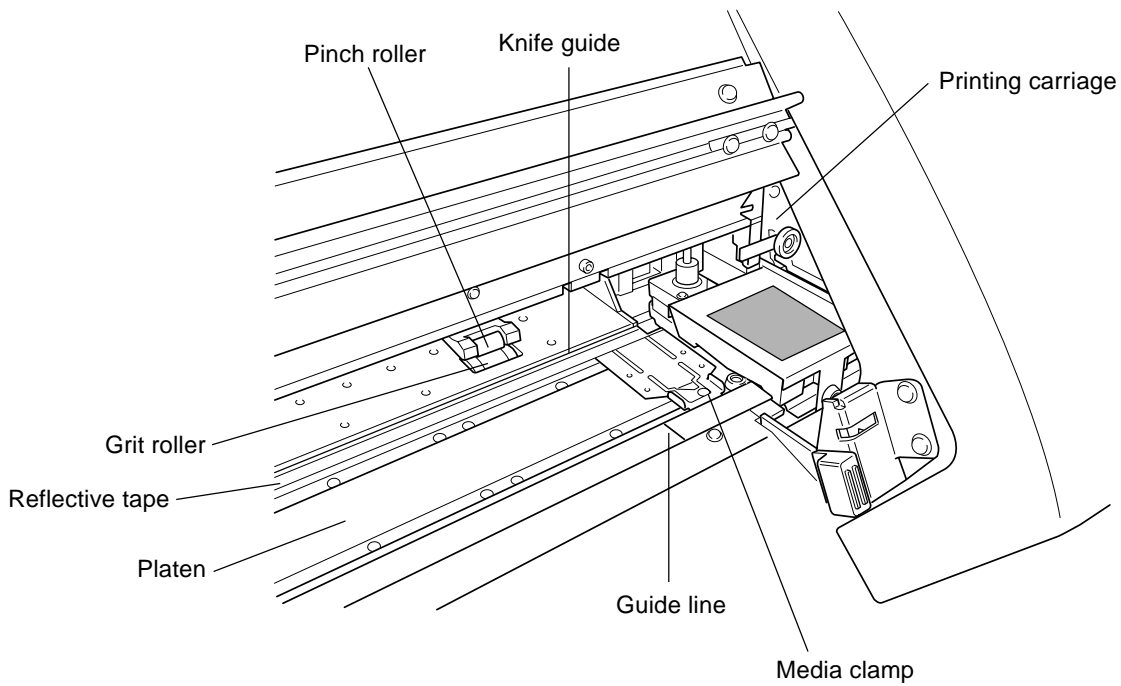

### Operation Panel

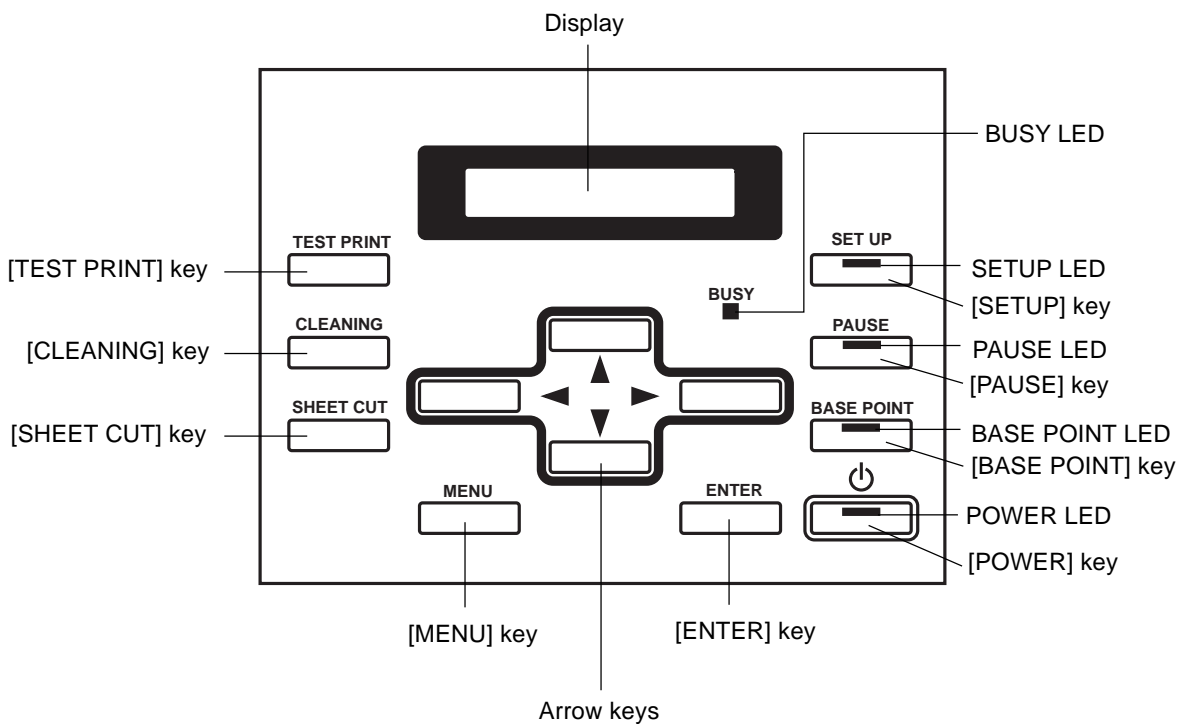

# 1-3 Assembling and Installing



**Unpacking, and installation must be carried out by four or more persons.**  
Otherwise the machine or the stand may fall, resulting in injury.



**Install in a level and stable location.**  
Otherwise the unit may tip over and cause injury.



**Use care to avoid pinching the fingers when placing the unit on the stand.**  
Doing so may result in injury.



**Use the joining bolts to secure the unit to the stand.**  
Failure to do so may result in falling of the unit, leading to injury.

## Installation Environment



### Notice

Never install the unit in any of the following situations, as it could result in breakdown or faulty operation:

- Places with excessive electrical noise.
- Places with excessive humidity or dust.
- Places with poor ventilation, because this machine generates considerable heat during operation.
- Places with excessive vibration.
- Places exposed to strong illumination or direct sunlight.

Never stand on the stand legs. Doing so may damage them.

Do not place objects on the unit, as doing so may result in breakdown.

The required installation spaces for this model is below.

3700 (W) x 2000 (D) x 1800 (H) mm (145-11/16 (W) x 78-3/4 (D) x 70-7/8 (H) in.)

## Step 1: Assemble the Stand

First assemble the stand, then mount the machine on top of the stand.

- 1 Invert the stand legs as shown in the figure. While supporting the stand legs with your hand, attach the left- and right-hand casters.



### Point

Tighten the bolts securely. Loose bolts may cause the stand to wobble.

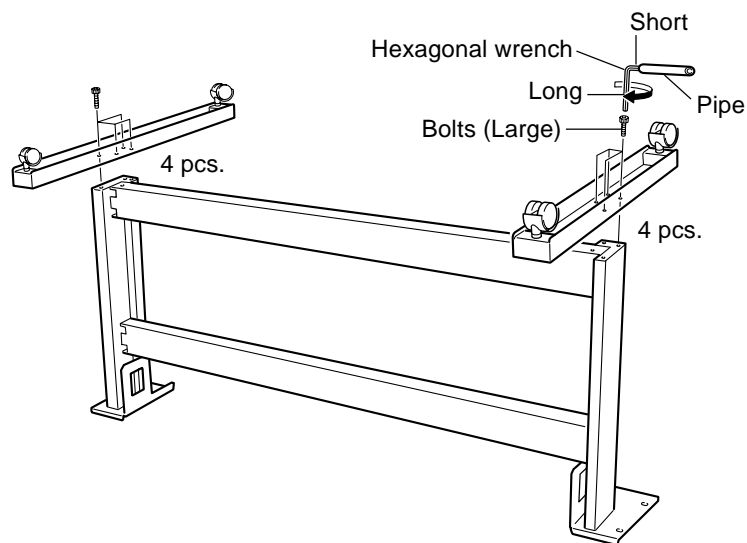

- 2 Set the stand upright so that the casters are at the bottom, and place the machine on the stand. The front and rear of the stand are as shown in the figure.

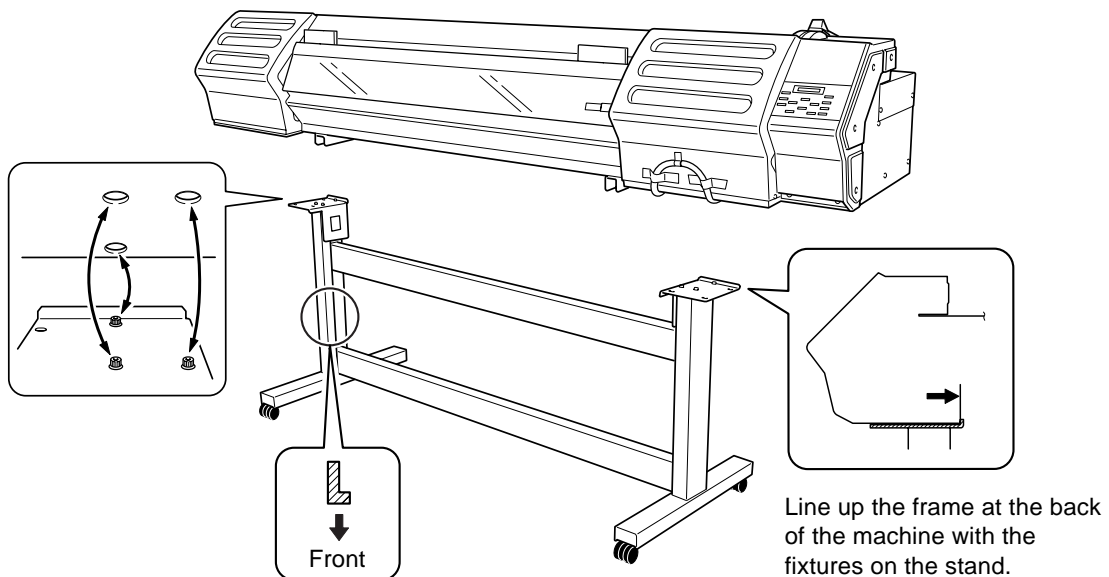

- 3** Use the included large bolts to secure the machine to the stand.

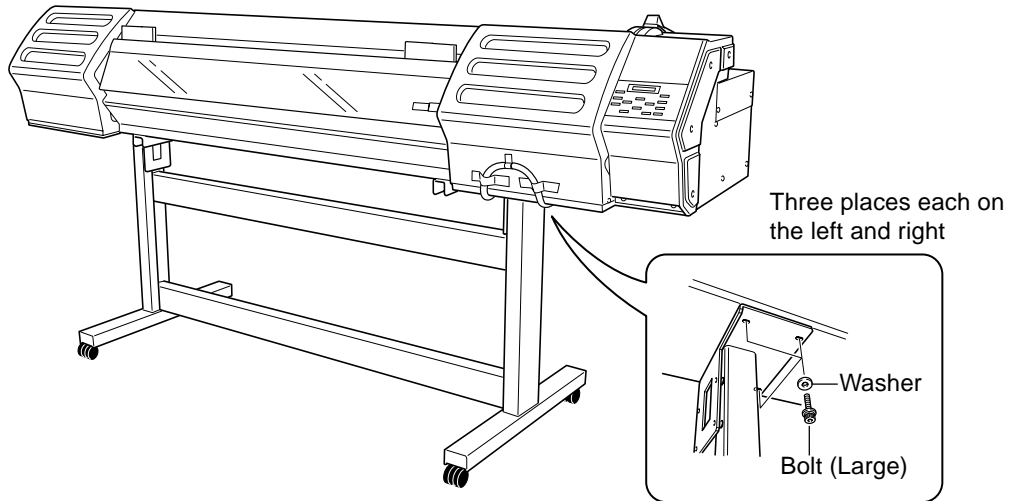

## Step 2: Install the Included Items

- 1 Attach the stays onto the back of the machine at the locations shown in the figure.

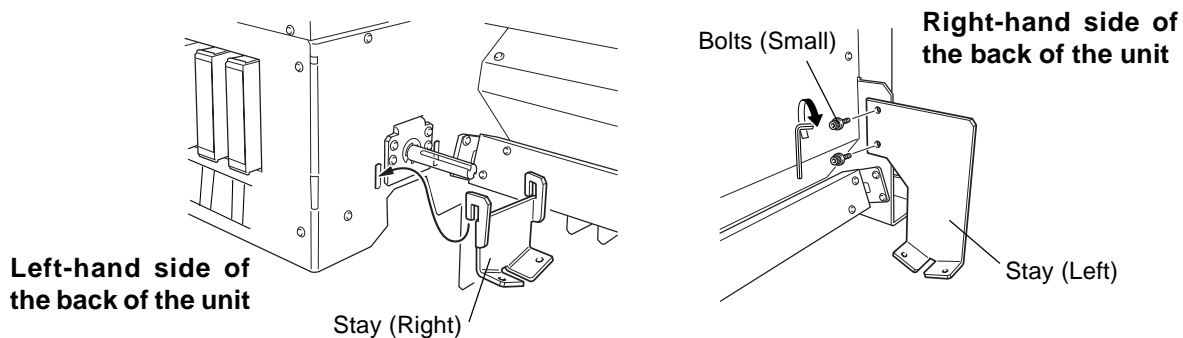

- 2 Place the media guide on the stays and secure it in place using the included small bolts.

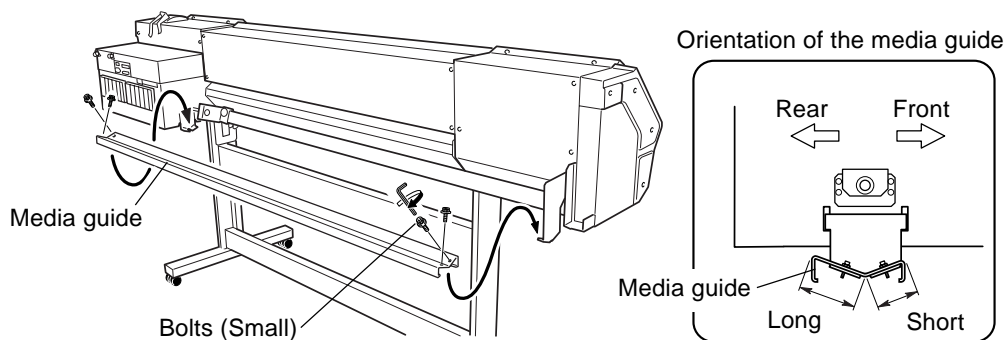

- 3 Pass the media flanges onto the retainers and secure in place with the flange retaining pins.

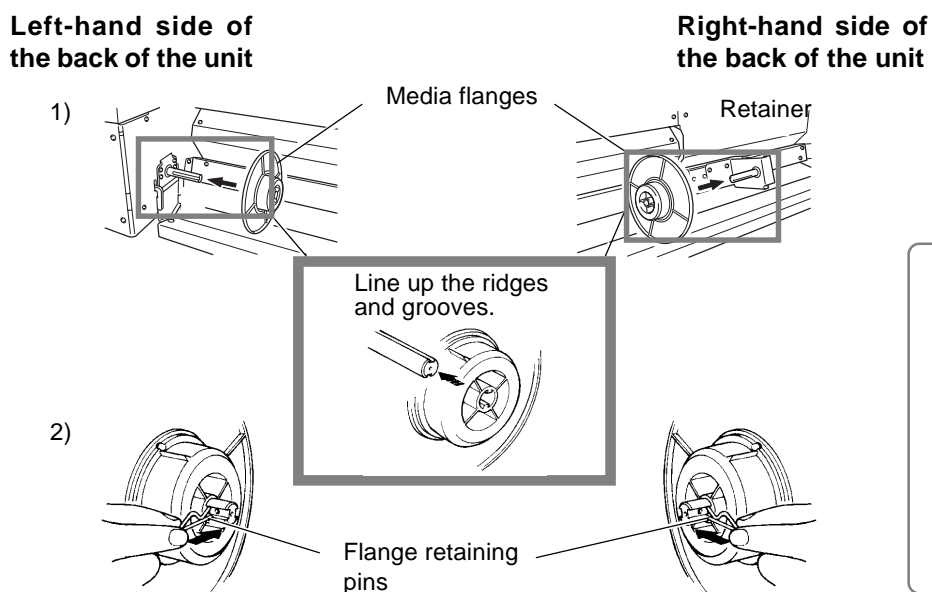

### Point

Orient the media flange so that it's lined up with the core diameter of the loaded roll media.

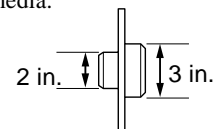

## Step 3: Install the Drain Bottle



### Point

Leave the drain bottle attached at all times, removing it only when moving the machine or disposing of collected ink.

- 1 Use the included large bolts to secure the bottle stand in place.

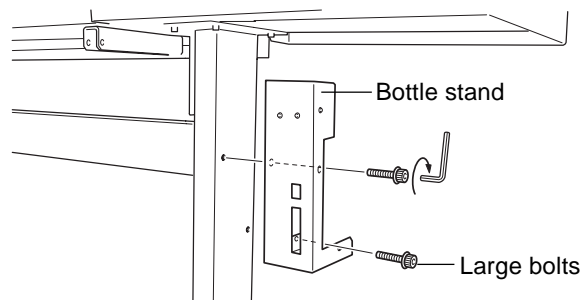

- 2 Remove the stopper from the drain tube.

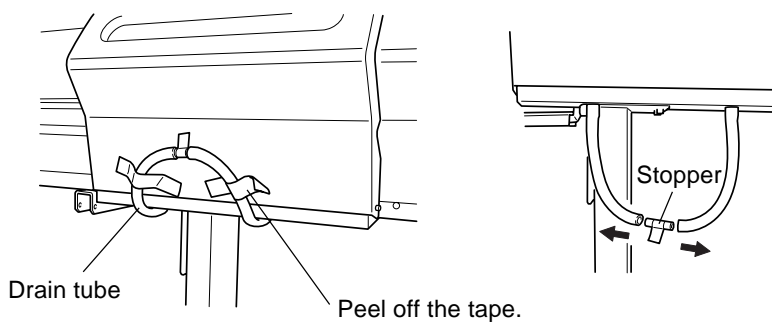

### ! Notice

When you remove the stopper from the drain tube, discharged fluid used in shipping inspection may be released from inside the tube. Exercise caution.

- 3 Insert the drain tube securely into the bottle stand.

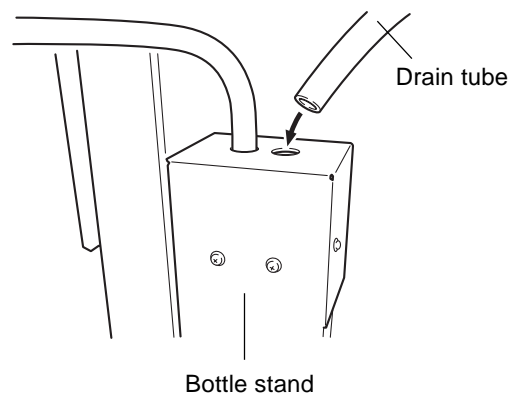

**4** Attach the drain bottle to the back of the machine.

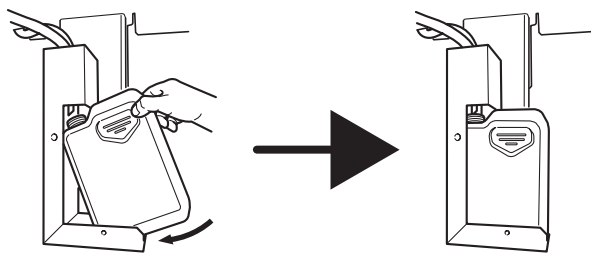

 **Point**

Before you attach the drain bottle, make sure the lid and the inner cover inside the drain bottle have been removed.

 **Point**

For more information about how to dispose of discharged ink.

☞ "4-5 Disposing of Discharged Ink"

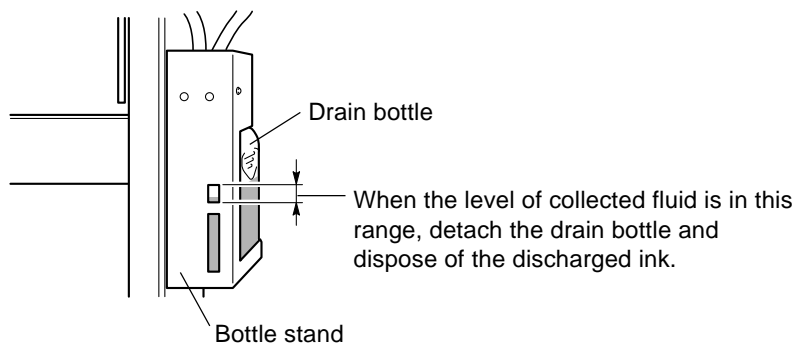



## Step 4: Remove the Protective Media

The protective media shown below is attached to this machine when it is shipped from the factory. When you have finished installing the machine, remove all protective media.

### Front

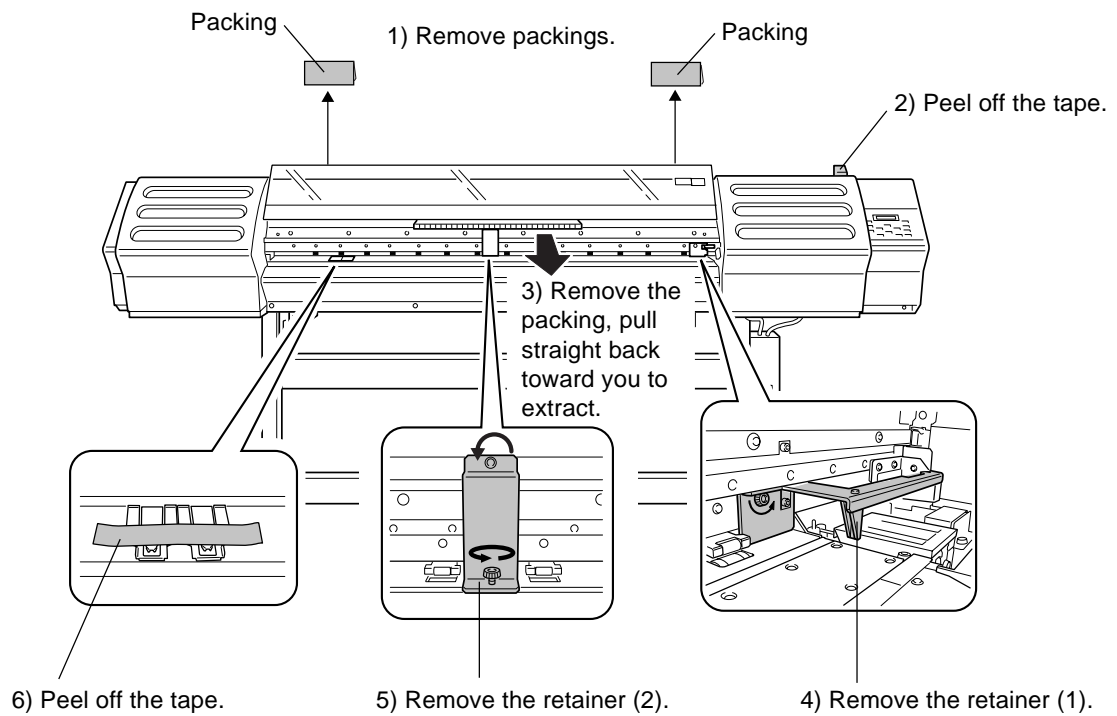

### Point

If the screw for the retainer is difficult to loosen, use a screwdriver to remove it.

### Rear

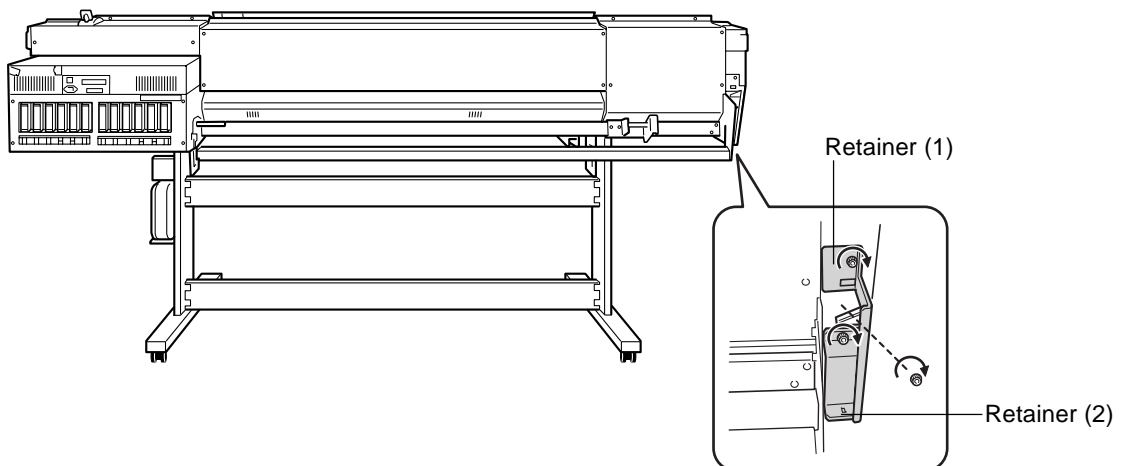

7) Attach the retainer you removed in step 4) and 5).

# 1-4 Connecting the Cables



**Use only with a power supply of the same rating as indicated on the unit.**  
Use with any other power supply may lead to fire or electrocution.



**Ground the unit with the ground wire.**  
Failure to do so may result in risk of electrical shock in the even of a mechanical problem.



**Use only with the power cord included with this product.**  
Use with other than the included power cord may lead to fire or electrocution.

## Connecting the Power Cord



### Notice

Securely connect the power cord, computer I/O cable and so on so that they will not be unplugged and cause failure during operation. Doing so may lead to faulty operation or breakdown.

Before connecting the cable, make sure the computer's power and the main power switch of the unit are switched off.

Arrange the power cord and interface connection cable to prevent tripping when moving around the unit.

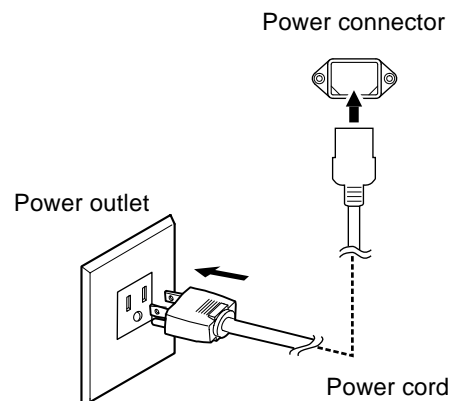
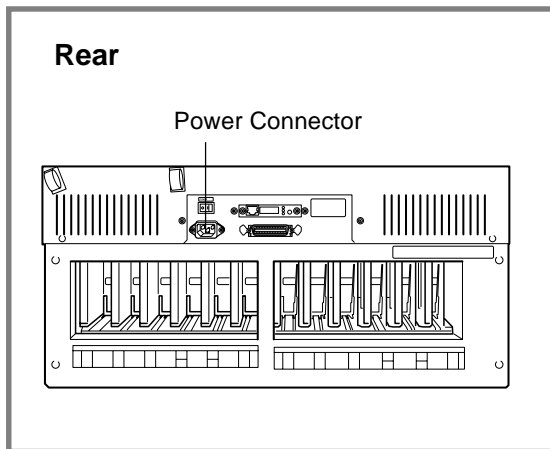

## Connecting to the Computer

### Ethernet Connection

RJ-45 (Ethernet) connector

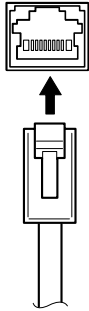

#### ! Notice

Do not connect a telephone cable to the RJ-45 (Ethernet) connector.

Network cable(category 5)

Ethernet (10Base-T or 100 Base-TX)

Various settings are required when using this machine in a network environment. For more information, see the “Roland PrintServer Network Settings Guide”.

### Connection to a Parallel Connector

When making the connection to the computer using a printer cable, connect the printer cable at the position shown in the figure.

\* Cables are available separately. One which you are sure matches the model of computer being used should be selected.

Rear

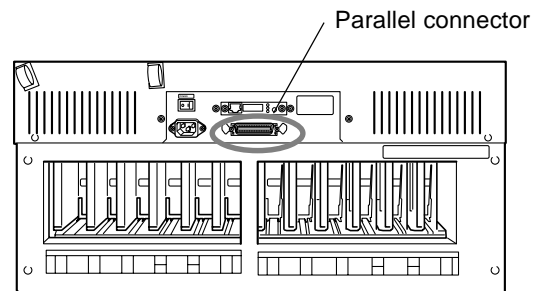

## ■ Securing the Cable

### ! Notice

Pass the cable through the established location, making sure that it does not touch the loaded media.  
If the cable touches the media during printing, media feed may be obstructed, resulting in poor printing accuracy.

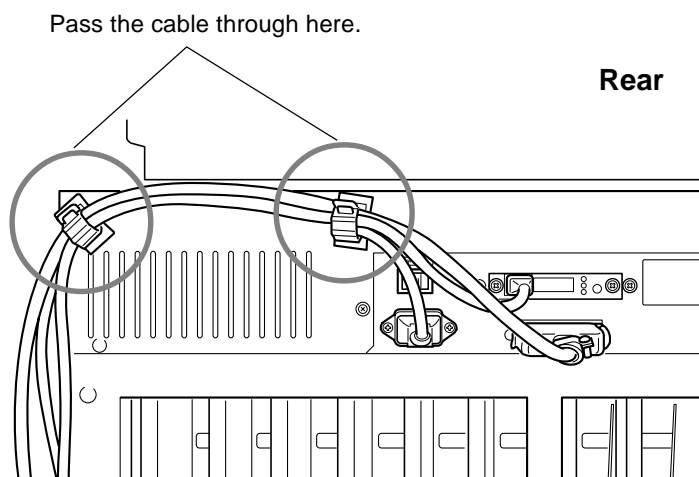

# 1-5 Switching On the Power for the First Time

## Step 1: Install Ink Cartridges



Store ink cartridges out of the reach of children.



If ink contacts the eyes, flush immediately with water.



### Notice

If an ink cartridge is dropped, the shock due to the fall may damage the ink cartridge and make it unusable.

Be sure to use genuine pigment or dye-based ink cartridges from Roland DG Corp. Installing other types of ink cartridges may result in incorrect color blending when printing or may cause malfunction.

## Confirming the Ink-insertion Sites

Before you insert a cartridge, be sure to examine the label on the ink-cartridge port and make sure the ink color matches the slot where it is to be inserted. Insert the same type and color of ink-cartridge into 1 through 6 and 7 through 12.

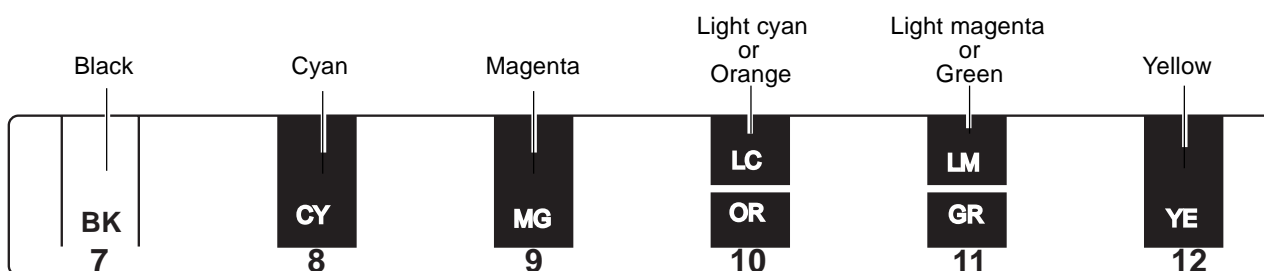
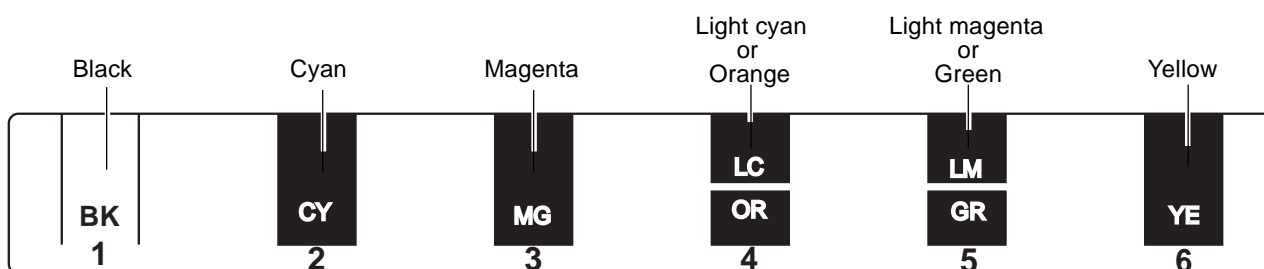

## Installing Ink Cartridges

Insert each ink cartridge into the corresponding ink-cartridge port. Insert it firmly, as far as it will go.

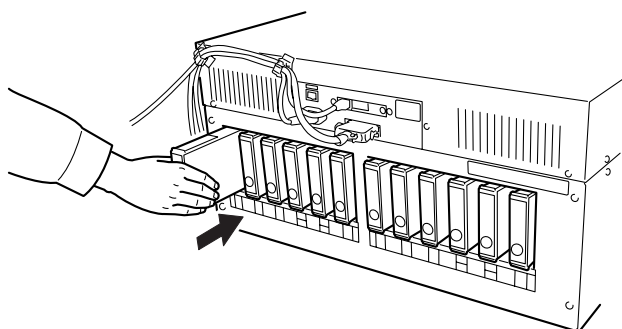

## Step 2: Perform Ink Filling

Make the setting for the ink type on the machine to match the installed ink. You can make the setting for the ink type when you switch on the power for the first time, or when you switch on the power after removing ink.

### Perform Ink Filling

**1** Switch on the main power switch on the back of the machine.

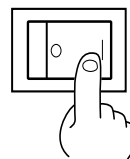

Switch to "I"

**2** Turn on the [POWER] key.

**3** Make sure the cartridges are installed into the ink-cartridge ports.

Select the installed ink type and press the [ENTER] key.

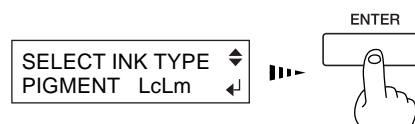

PIGMENT LcLm  
: Pigmented ink  
(cyan, magenta, yellow, black,  
light cyan, and light magenta)  
PIGMENT OrGr  
: Pigmented ink  
(cyan, magenta, yellow, black,  
orange, and green)  
DYE LcLm  
: Dye-based ink  
(cyan, magenta, yellow, black,  
light cyan, and light magenta)

**4** Follow the messages to make sure the drain bottle is installed at the back of the machine.

The ink-filling operation starts.  
This operation takes several minutes.



## ***2. Basic Operation***

---

This describes the sequence of basic operations from switching on the power to performing printing.

# 2-1 Switching the Power On and Off

## Switching On the Power

Leave the main power switch turned on, and use the [POWER] key to switch the power on and off in day-to-day use.

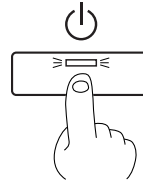

### **Notice**

#### **Points to Keep in Mind When Switching the Power On and Off**

Do not switch off the main power while the sub power is switched on. The printing heads may be left uncapped (that is, the printing carriage may remain over the platen). If the machine is allowed to stand with the printing heads uncapped for a prolonged period, the printing heads may become irreversibly clogged.

Before switching off the main power, be sure to hold down the [POWER] key for one second or longer to switch off the sub power.

If the printing carriage stops while over the platen, press the [POWER] key to reset the power. The printing carriage moves and the printing heads are capped.

If the printing carriage does not move even when you reset the power using the [POWER] key, refer to "6-1 What to Do If -- What to Do When the Printing Carriage Does Not Move."



## Switching Off the Power at the End of the Day

Press and hold down the [POWER] key for one second or longer to switch off the sub power.

The POWER LED goes out

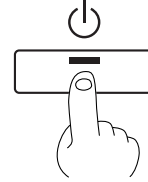

### **Notice**

Leave the pinch rollers raised when not in use.  
Deformation may occur if left lowered for a prolonged period.

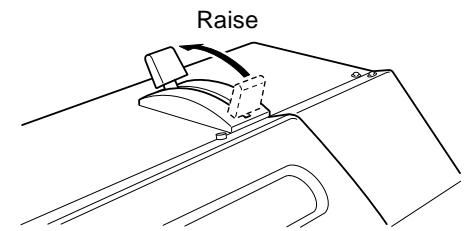

## 2-2 Loading Media

**!** Be sure to install the media guide when loading roll media.  
Otherwise the roll may fall and cause injury.

**!** Load roll media at the proper position.  
Otherwise the roll may fall, resulting in injury.

### **!** Notice

Do not touch the rail or the inner side of the left and right cover. Touching the area shown may cause the fingers to be soiled by grease or ink, and may result in diminished image quality.

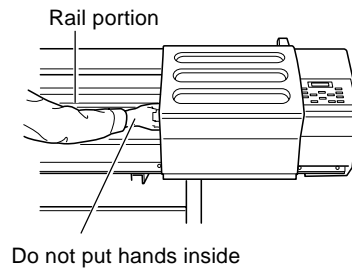

## Loading Roll Media

**1** Open the front cover.

**2** Line up with the core diameter of the loaded roll media and refit the left- and right-hand media flanges.

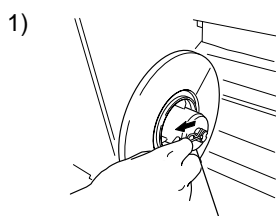

Flange retaining pin

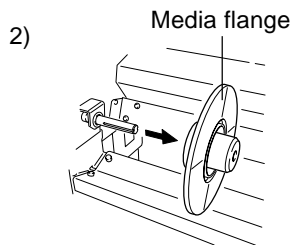

Media flange

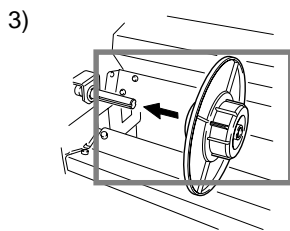
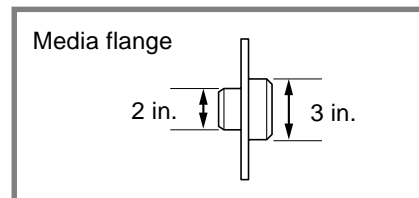

Line up the ridges and grooves.

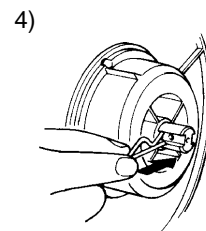
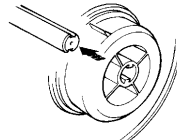

**3** Fit the hole on the left side of the roll media all the way onto the left-hand media flange.

- 4** Fit the right-hand media flange all the way into the hole on the right-hand side of the roll media, and tighten the retainer screw to secure in place.

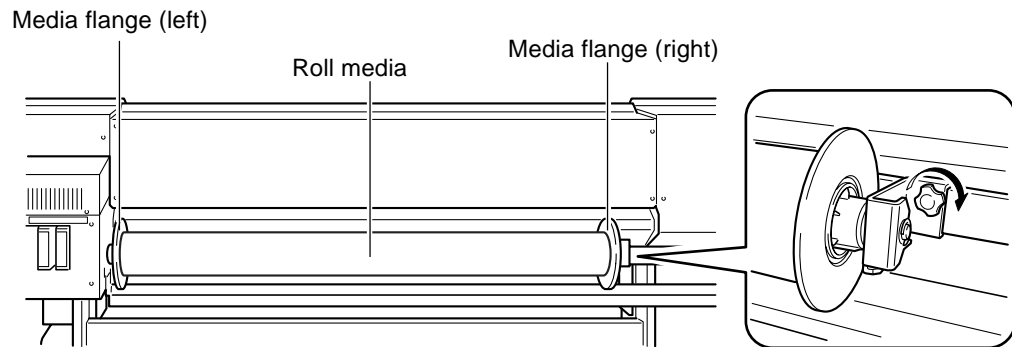

- 5** Move the media clamps to the two ends of the platen.

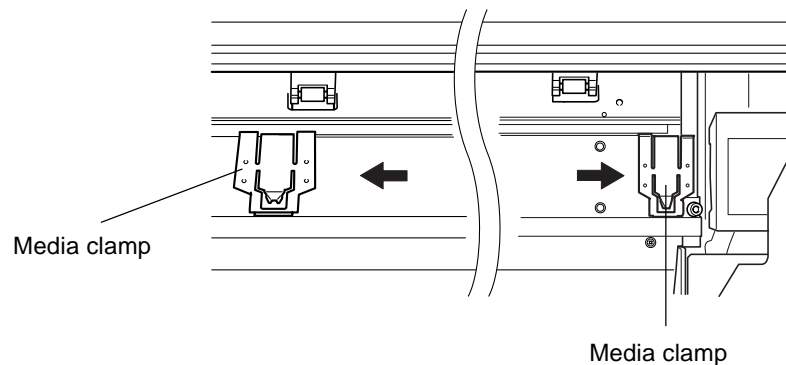

- 6** Pass the end of the media from the back of the machine to the front.  
Pull out the media until the sensor is hidden from view.

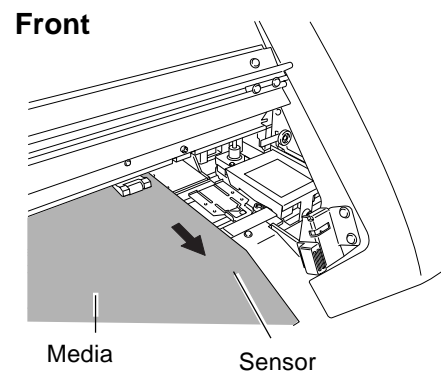

- 7** Grasp the center of the end of the media at the front of the machine, and slowly pull the media out straight to the position shown in the figure.

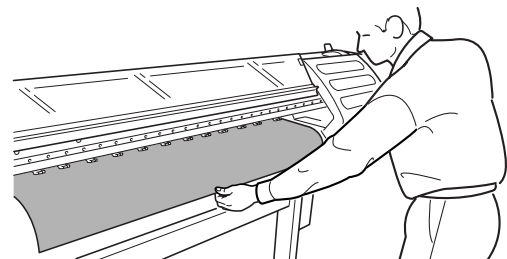

- 8** Slowly turn the media flanges at the back of the machine to pull back the media to the position shown in the figure.

When you roll back the media until the sensor comes into view, a tight seal is formed between the media and the platen, and the media is stretched taut.

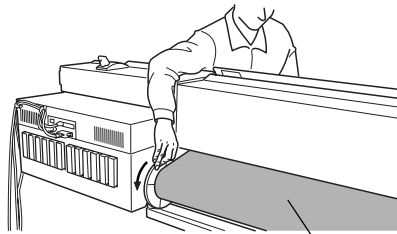

Entire media stretched taut

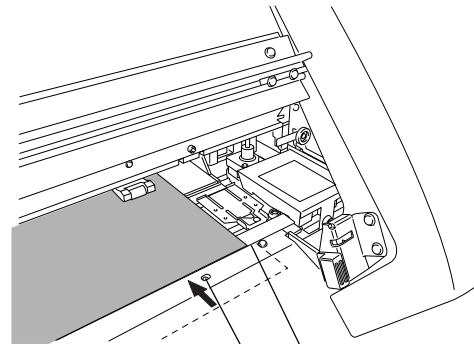

Sensor Pull back the media here.

- 9** With the media pulled out from the roll stretched taut with no slack, move the sheet loading lever toward LOAD.

The pinch rollers lower to hold the media in place.

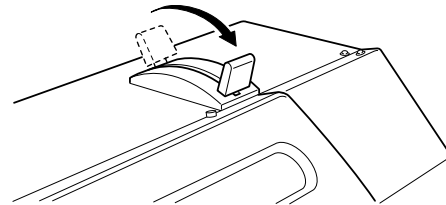

- 10** Close the front cover, and press the [SETUP] key. This detects the width of the media and displays the printable width.

The SETUP LED lights up



**! Notice**

When the machine will remain unused for an extended period, remove roll media from the machine and store it. If roll media is left mounted on the machine for an extended period, these entire roll may warp, resulting in poor printed image quality or motor errors.

**🔗 Point**

When transparent media is loaded, it is necessary to set [SHEET TYPE] to [CLEAR]. For more information, see "3-5 Using Transparent Media".

When changing to a different type of media, it may be necessary to perform feed correction or bidirectional correction. For more information, see "3-6 Making Corrections for Printing -- Bidirectional correction".

For information about the conditions of media that can be used and loadable media widths, see "7-2 Media Conditions."

## Loading Sheet Media

Before attempting to load sheet media, check the following points.

### Front View

Line up the right edge of the media with the guide line, and align the front edge with the location shown in the figure.

If the front edge of the media is cut at an angle, load the media so that its edge is lined up straight with the guide line.



#### Point

Be sure to line up the right-hand edge of the media with the guide line.

If the media is not positioned correctly when you press the [SETUP] key, the message "SHEET SET ERROR SET AGAIN" appears on the display.

### Front

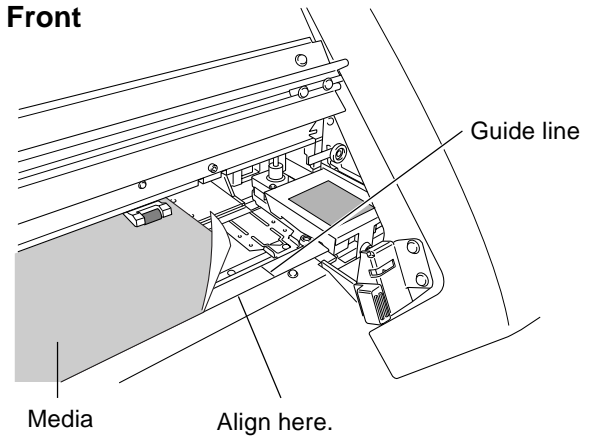

### Rear View

Remove the left-hand media flange at the back of the unit. Move the right-hand media flange at the back of the unit to a position where it does not touch the loaded media.

Drape the pulled-out media at the back between the machine and the media guide.

### Rear

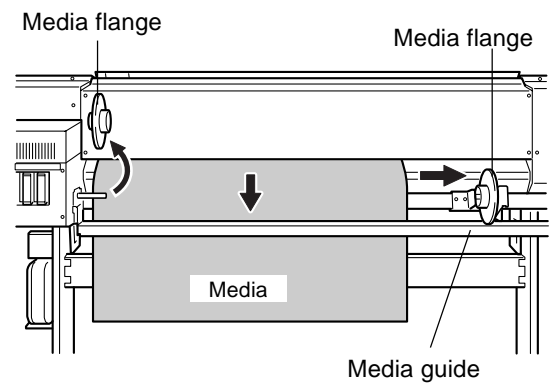

## When Loading Thick Media

Media that is thick or that warps easily may lead to problems with media feed or jamming. When you are using such media, adjust the height of the printing heads.



### Point

When the height of the printing head has been adjusted, it is necessary to perform bidirectional correction. For more information about bidirectional correction, see "3-6 Making Corrections for Printing -- Bidirectional Correction."

For more information about the thicknesses of media that you can load, see "7-2 Media Conditions."

## Adjusting the Head Height

The head height is setting at position 2 (middle) when shipped from the factory.

**1** Open the front cover.

**2** Press the [MENU] key and the [▼] key to display the screen shown in the figure.

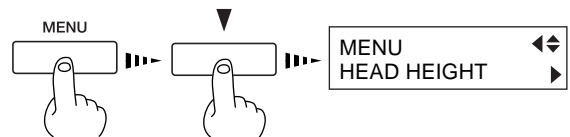

**3** Press the [▶] key to display the screen shown in the figure.

When the screen shown in the figure appears, the printing carriage simultaneously moves to the left.

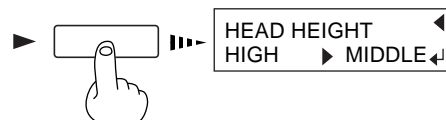

**4** Move the lever to adjust the height of the head.

When you move the lever, the machine beeps and the screen display changes.

- When the lever is moved to position 1 (low): One beep
- When the lever is moved to position 2 (middle): Two beeps
- When the lever is moved to position 3 (high): Three beeps

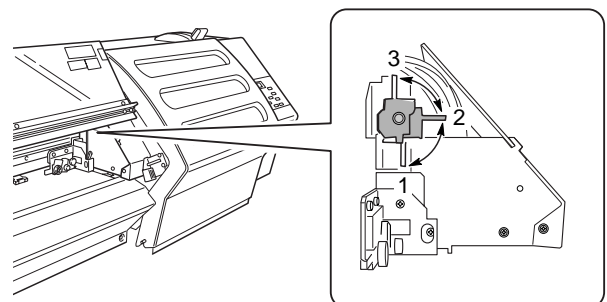

### Point

Move the lever until it stops. If it is not at position 1, position 2 or position 3, bidirectional printing may be misaligned.

**3 (high)** : When media that is thick or prone to warping is loaded

**2 (middle)** : Standard

**1 (low)** : Suitable for high image quality

**5** Close the front cover.

The printing carriage return to the standby position.

## When Loading Media That Warps Easily

When you are loading whose left and right edges are prone to warping, use the media clamps. The media clamps can be used to secure media that is up to 0.7 mm (0.027 in.) or so in thickness.

### **!** Notice

The following media cannot be used even when secured in place by the media clamps.

- Media whose warping is not corrected by securing it in place
- Media that deforms the media clamps when it is secured in place
- Media that is prone to warping and that has a thickness of 0.7 to 1 mm (0.027 to 0.039 in.)
- Media with a strong tendency to curl

Attempting to force such media to be loaded may result in malfunction.

Do not use the media clamps when performing printing with the height of the printing heads set at position 1. The media clamps may scrape the printing heads.

### Securing in Place Using the Media Clamps

**1** Position the printing heads at 2 (middle) or 3 (high).

**2** With your finger, lightly press down on each media clamp at the location shown in the figure to move it and make it grip the media.

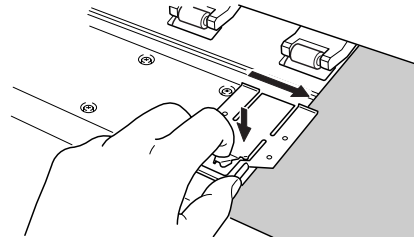

**3** Line up the holes in the media clamps with the left and right edges of the media.

### **!** Point

Set the media clamps at the correct locations. If they are not set at the correct locations, the media may catch or cause other problems.

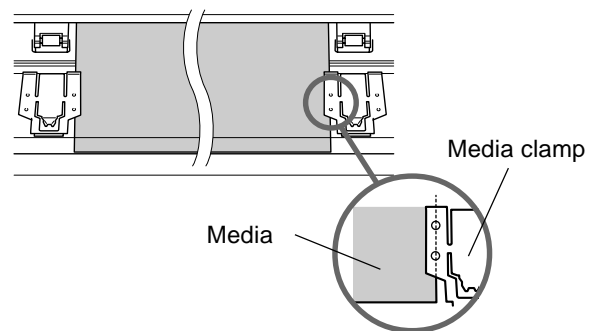

### **!** Notice

When you cut off media while using the media clamps, then depending on the media, it may come loose from the media clamps. After you cut off the media, check to make sure that the media has not come loose from the media clamps.

As printing proceeds, the media may move to the left right and touch or come loose from the media clamps. After about 1 m (3 ft.) of media has been fed, check the positioning of the media clamps. If the media looks like it may come loose from the media clamps, adjust the positioning of the media clamps.

The media clamps are designed to press down on a space 10 mm (7/16 in.) inward from either edge of the media. Do not perform printing within these areas.

## Separating the Media

Make sure the [SETUP] LED lights up.

To cut off a printed portion from the roll, hold down the [SHEET CUT] key for at least one second.

The piece is cut off at the present location of the printing-start line. Depending on the composition of the media, cutoff may not be possible.



### Point

This step is not necessary when cutoff is performed automatically by sending a media-cutoff command from the computer.

When you're performing cutoff, do not use the [▲] key to pull the media back. Unless the end of the media has been pulled out to a location to the front of the platen, cutoff may not be performed smoothly.

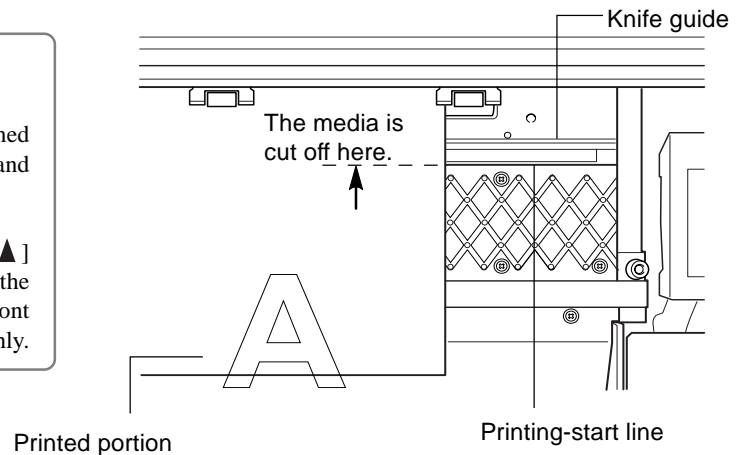

## Removing the Media

**1** Refer to the previous section, "Separating the Media," and cut off the media.

**2** When the SETUP LED is lighted, hold down the [SETUP] key for at least one second.

The SETUP LED goes out

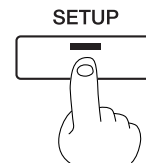

**3** Move the sheet loading lever toward the back of the unit.

The pinch rollers rise to release the media.

Sheet loading lever

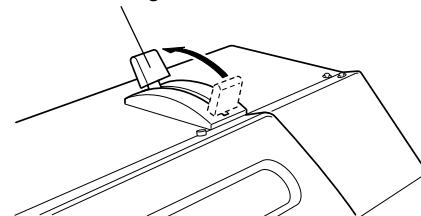

**4** Remove the media.



## 2-3 Printing

### **Notice**

Do not open the front cover. Opening the front cover while printing is in progress causes an emergency stop. This means that printing may not be carried out correctly even if operation is resumed, due to drop-out or misalignment of the image.

During printing, do not touch the portion of the media that's already been discharged.

Doing so may obstruct media feed or cause the media to rub against the heads, which may result in a paper jam or damage to the heads.

The printing heads may be left uncapped (that is, the printing carriage may remain over the platen). If the machine is allowed to stand with the printing heads uncapped for a prolonged period, the printing heads may become irreversibly clogged.

Before switching off the main power, be sure to hold down the [POWER] key for one second or longer to switch off the sub power.

Also, if the printing carriage stops while over the platen, press the [POWER] key to reset the power. The printing carriage moves and the printing heads are capped.

If the printing carriage does not move even when you reset the power using the [POWER] key, refer to "6-1 What to Do If -- What to Do When the Printing Carriage Does Not Move."

## To Perform Printing

Before performing a printing test or starting printing, make sure the following two points have been carried out.

- Media is loaded and the front cover is closed.
- The SETUP LED is illuminated.

Pressing the [SETUP] key detects the width of the media and displays the printable width.

### **Point**

#### **How to Load Media**

For information on how to load media, refer to "2-2 Loading Media."

#### **The [SETUP] Key**

Pressing this for one second or longer clears the media setup.

If another menu screen is displayed, the media setup is not cleared simply by pressing the [SETUP] key.

## Performing a Printing Test

Before starting to print, carry out a Test print to check the state of the head.

Problems such as missing dots may reduce the printing quality.

If the test results show a problem, carry out head cleaning to restore the head to its normal state.

- 1 Press and hold the [TEST PRINT] key for at least one second to carry out a printing test.  
The test pattern is printed.

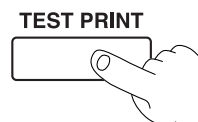

- 2 If dot drop-out is present, clean the heads.  
For more information about head cleaning, see "4-1 Cleaning the Printing Heads."

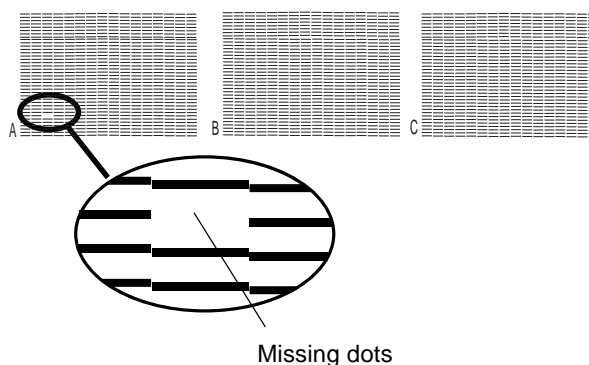

## Downloading Printing Data

Printing is started when data is sent.

If the top menu isn't displayed, printing doesn't start even when data is sent from the computer. If another menu screen is displayed, press the [SETUP] key, and display the top menu.



### Point

#### Conditions for starting printing

- The media must be already set up (with the SETUP LED lighted).
- The display must show the top menu.

#### Top menu

W 1234 mm

## ***3. A Wide Variety of Operations***

---

This section describes a wide variety of operations and functions, grouped by task.

# 3-1 Replacing the Ink Cartridges

## Care and Handling of Ink Cartridges

### **Notice**

- Do not attempt to disassemble an ink cartridge.
- If an ink cartridge is dropped, the shock due to the fall may damage the ink cartridge and make it unusable.
- Unused ink cartridges should be stored unopened at a temperature of -20°C (-4°F) to 40°C (104°F).
- Do not remove any ink cartridges except when shipping the machine.
- Do not allow a removed ink cartridge to sit out for any length of time. Doing so may result in clogging of the heads.
- Use only the type of filled ink specified for the machine.
- If ink runs out, replace immediately with an ink cartridge designed especially for the machine.
- Do not attempt to refill and reuse an empty ink cartridge. If an ink cartridge is removed, replace it immediately with a new one.
- When removing an ink cartridge, do not rush. Detach the cartridge gently. Sudden movement when detaching may cause ink to be spilled.
- Once an ink cartridge has been installed, do not remove it until the ink has been used up. Frequent insertion and removal may allow air to enter the ink tube and result in a drop in printing quality due to dot drop-out or the like.

## Replacing with New Ink Cartridges

### Replacing an Ink Cartridge

Before you attempt to replace an ink cartridge, check the following two points.

- The machine is switched on.
- Operation is stopped or paused.

#### **Notice**

Removing or inserting an ink cartridge while operation is in progress may cause air to get inside the cartridge, resulting in poor image quality.

- 1** Remove the ink cartridge from the ink-cartridge port.

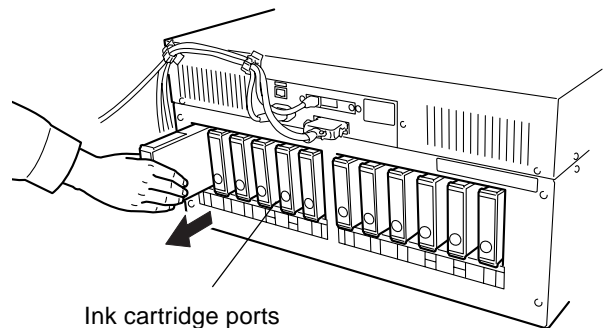

- 2** Insert new ink cartridge.

#### **Notice**

Be sure to use genuine pigment or dye-based ink cartridges from Roland DG Corp. Installing other types of ink may result in breakdown or faulty operation.

## If ink runs out during printing

If ink runs out during printing, a warning beep sounds and the screen shown in the figure appears. Replace the ink cartridge. Ignoring the message and continuing printing without replacing the ink may adversely affect image quality, resulting in faintness or other problems.

1	2	3	4	5	6
7	8	9	10	11	12

The "\_\_\_" for the ink that has run out flashes. The number indicates the number of the ink cartridge.

The flashed number indicate the ink cartridges at the locations shown in the figure.



## Replacing Ink (When Set to the [STOP] Mode)

- 1 Pull out the ink cartridge indicated by the flashing number on the display.
- 2 Install a new ink cartridge.



### Point

The behavior that occurs when it becomes necessary to replace ink while printing is in progress differs according to whether the selection for [EMPTY MODE] under [INK CONTROL] is set to [CONT.] or to [STOP]. (The default setting is [STOP].)

#### When Set to [STOP] (Pause)

[STOP] causes operation to pause immediately when ink needs to be replaced. Operation resumes when ink is replaced. Note, however, that the colors of an image in progress may no longer match perfectly if the unit is allowed to remain paused for two or three hours before resuming printing.

#### When Set to [CONT.] (Continue Printing)

Select this when ink cannot be replaced immediately while printing in progress, such as during unattended operation at night. When the machine is set to [CONT.], an alarm sounds approximately 1 m<sup>2</sup> before ink runs out, but printing continues without pausing. Because printing continues with only a small amount of remaining ink, the printed ink may be faint. As a general guide, about 1 m<sup>2</sup> of printing is possible with the remaining ink, but the amount of ink used varies greatly depending on the image. Printing can be continued only for the data for which printing is currently in progress. The machine stops when it finishes outputting one image.

## 3-2 Checking the Remaining Ink Level

You can use [INK REMAINING] on the display menu to check how much ink is left after the ink cartridges have been installed.

Use this information as a guide for replacing the ink cartridges.



### Point

In situations such as the following, the installed ink cartridge is taken to be an unused cartridge and the default amount of remaining ink is displayed, which does not match the actual amount of ink remaining.

- When an ink cartridge is removed and reinstalled while printing is in progress
- When a partly used ink cartridge is installed

- 1** Press the [MENU] key and [▼] key to make the following screen appear on the display.

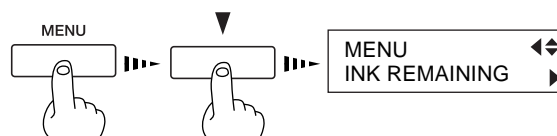

- 2** Press the [▶] key to make the following screen appear on the display.

You can check the amount of remaining ink for ink cartridges 1 through 8.

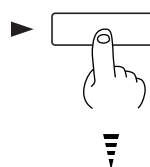

<Remaining ink > **Much**

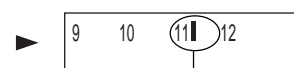

The fewer the markers, the less is the amount of ink left.

- 3** Continuing by pressing the [▼] key lets you check the amount of remaining ink for ink cartridges 9 through 12.

# 3-3 Setting the Location Where Printing Starts

## Setting the Start Location

Set the location where printing starts at the desired place.

[▲], [▼], [▶], and [◀] keys and the [BASE POINT] key to set the start points (origin points) for the feed direction (the direction of forward and backward movement) and the scan direction (the direction of movement of the printing carriage).

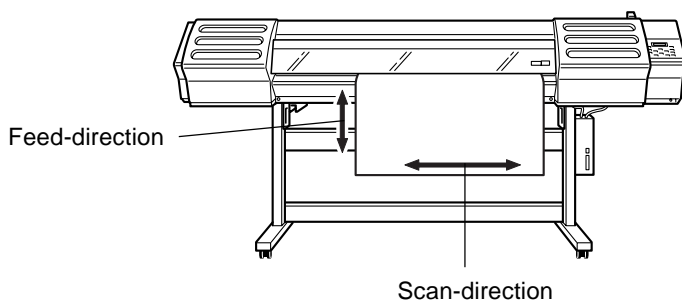
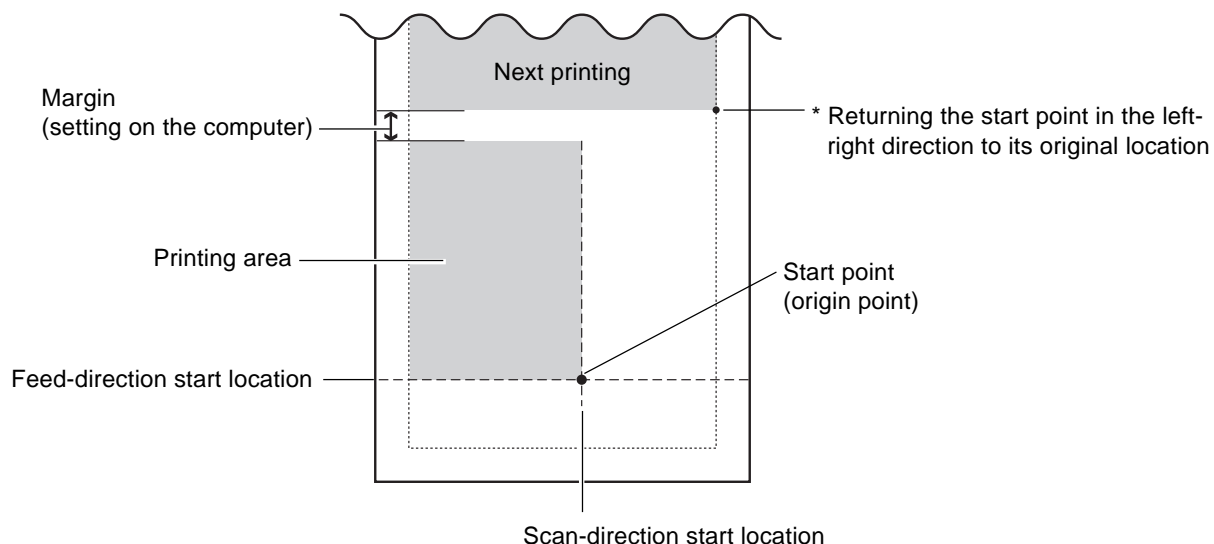

### Point

When using [BASE POINT] key to change the print-start location, check the size of the data to print before you set the start position.



## Specifying a Location in the Feed Direction

Use the [ ▲ ] [ ▼ ] keys to move the media to the location where you want to start printing. In the figure, the next printing operation starts from the location shown.

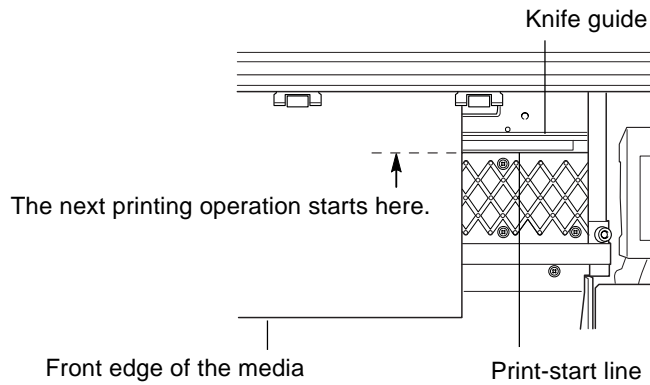

### ! Notice

Whenever possible, avoid using the [ ▲ ] key to pull back the media. Otherwise the following may occur.

- The pinch rollers may pass over the printed surface and smudge the ink.
- The grit rollers may leave tracks on the media, reducing printing accuracy.
- Printing may sag.

### 🔗 Point

For roll media, when the media has been returned toward the back of the unit with the [ ▲ ] key, manually roll the media back onto the roll so that all of the media at the back of the unit is stretched taut.

## Specifying a Location in the Scan Direction

- 1 Press the [◀] key to move the printing carriage to the present starting location for printing in the scan direction.

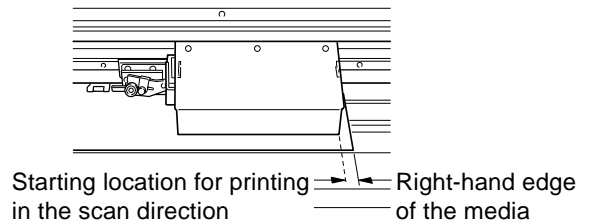

- 2 Use the [◀] and [▶] keys to move the marker to the new print-start position.

The printable width appears on the display.

### Point

If the printing carriage moves away from the standby position when not printing, problems such as drying-out of the printing heads or dot drop-out during printing may occur. For this reason, about 60 seconds after pressing the [◀] key to move the printing carriage, the printing carriage returns to the standby position.

Also, the printing carriage returns to the standby position when about 30 seconds passes during this interval after the [◀] and [▶] key is released. If the setting could not be made in within the time limit, then do the setting over again from the beginning.

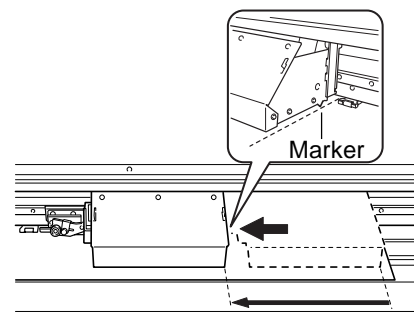

### Top menu

W 1234 mm

- 3 Press the [BASE POINT] key.

The BASE POINT LED lights up

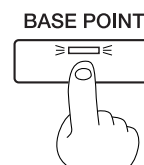

- 4 Press the [ENTER] key.

The printing carriage moves to the standby position.

### Point

#### Canceling the Setting

A position set using [BASE POINT] key is canceled in situations like the following.

- When one page was printed
- When media setup is canceled by pressing the [SETUP] key

# 3-4 Setting the Margins

## Setting the Margins in the Feed Direction

You can set the margins in the feed direction using the software RIP (raster image processor). For information about how to make the settings for the margins, refer to the documentation for the RIP you're using.

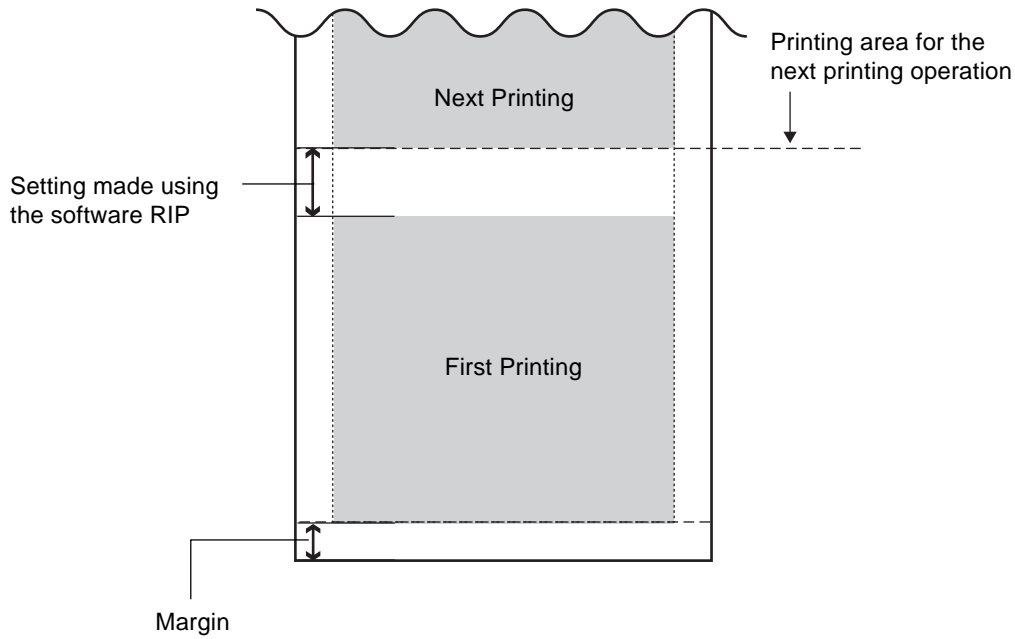

### Point

When a media-cutoff command is sent from the computer during continuous output, the value for the margin between the first printing and the next printing differs. For more information about margins, see "7-4 The Media-cutoff Location During Continuous Printing."

## Setting the Margins in the Scan Direction

Set the left and right margins for the printing area.  
You can set the scan-direction (left and right) margins only at the time of media setup.

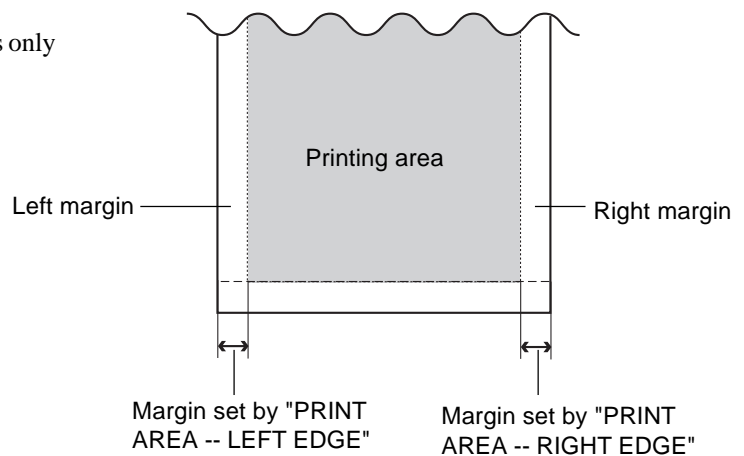

### ! Notice

If the printing carriage moves away from the standby position when not printing, problems such as drying-out of the printing heads or dot drop-out during printing may occur. For this reason, about 60 seconds after pressing the [ ◀ ] key to move the printing carriage, the printing carriage returns to the standby position.

Also, the printing carriage returns to the standby position when about 30 seconds passes during this interval after the [ ◀ ] and [ ▶ ] key is released. If the setting could not be made in within the time limit, then do the setting over again from the beginning.

When the printing area is set to the full width of the media, fluctuations in media-width detection or slight crookedness of the media may result in printing outside the media, causing soiling of the platen. If this happens, then do not specify a printing area. Instead, use the default printing area in effect when the media is set up.

### 🔗 Point

After setting the printing area, pressing the [SETUP] key to cancel the setup for the media (making the SETUP LED go out) cancels the printing area that has been set.

Using [PRINT AREA] to set the printing area when the starting location in the scan direction has been specified with the [BASE POINT] key, the setting made with the [BASE POINT] key is canceled.

- 1 Press the [MENU] key and [ ▼ ] key to display the screen shown in the figure.

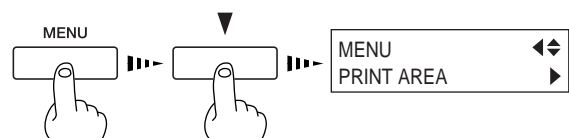

- 2 Press the [ ▶ ] key to display the screen shown in the figure.

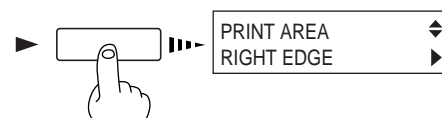



# 3-5 Using Transparent Media

If the media loaded on the unit is transparent, then at the [SHEET TYPE] menu, select [CLEAR].



### Point

When [SHEET TYPE] is set to [CLEAR], the media width is not detected during media setup. This means it is necessary to specify a printing area that matches the actual width of the media.

When only set to [CLEAR], the printable width is set to the maximum. For more information about printing area, see "7-3 Printing Area."

## [SHEET TYPE] Selection Procedure

- 1 Press the [MENU] key and [▼] key to make the following screen appear on the display.

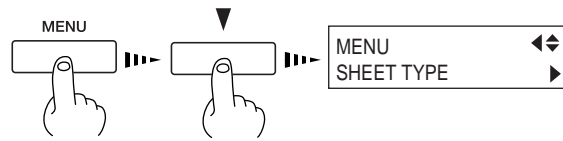

- 2 Press the [▶] key to make the following screen appear on the display.

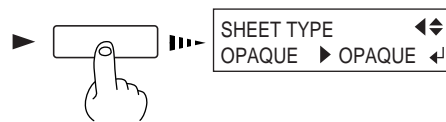

- 3 Use the [▲] and [▼] key to select [CLEAR], then press the [ENTER] key.

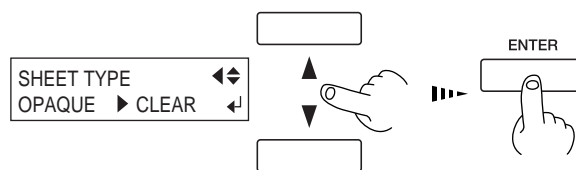

- 4 Specify a printing area for the left-right direction (the direction of printing carriage movement) that matches the width of the media.

For more information, see "3-4 Setting the Margins -- Setting the Margins in the Scan Direction."

# 3-6 Making Corrections for Printing

## Feed Correction

This corrects for errors in the amount of feed of the grit rollers due the type of media.

Be sure to make this setting when you have replaced the media with a different type.

Correcting the amount of feed improves the dot-positioning accuracy in the feed direction, which can help enhance image quality.

### Point

When correcting the amount of feed, set the same conditions for the type of media used and the configuration of the media (roll media or sheet media) as when actually performing printing.

When performing test printing for feed correction, load the media correctly (see "2-2 Loading Media"). If the media is not loaded correctly, an accurate correction value may not be output.

When you can set the error for the amount of feed for the grit rollers on the computer, the computer's setting takes priority. To make the machine's setting take priority, turn off the computer's setting.

## Feed Correction

- 1 Press the [MENU] key and [▼] key to make the following screen appear on the display.

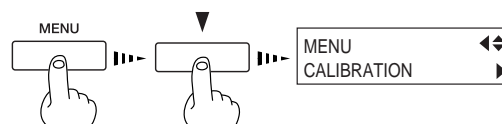

- 2 Press the [▶] key to make the following screen appear on the display.



- 3 Press the [ENTER] key to start printing a test pattern.

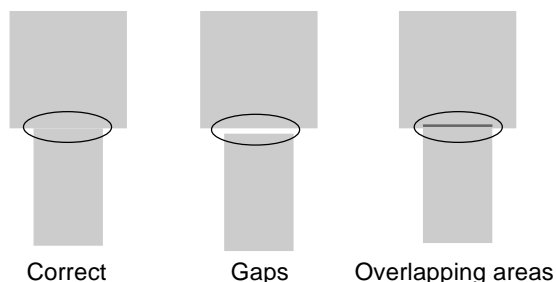

- 4 Press the [▼] key to make the following screen appear on the display.

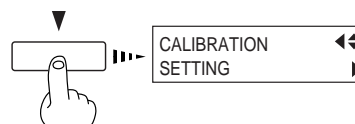

- 5 Press the [▶] key to make the following screen appear on the display.

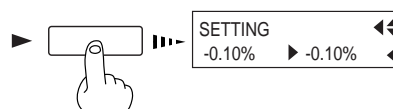

- 6 Use the [▲] and [▼] keys to set the value you, then press the [ENTER] key.

Perform correction to ensure uniform dot spacing: If there are gaps in the test pattern, reduce the value. If there are overlapping areas in the test pattern, increase the value.

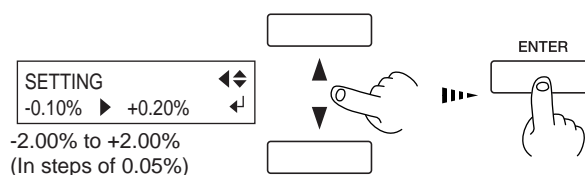

## Bidirectional Correction

This adjusts for misalignment that occurs during bidirectional printing. Perform adjustment for bidirectional correction in situations such as the following.

- When media is replaced with a different type
- When the head height has been adjusted
- When using in a location subject to large changes in temperature



### Point

Bidirectional correction is enabled only when performing bidirectional printing.

### Setting Adjustment Value

- 1 Press the [MENU] key and [▼] key to make the following screen appear on the display.

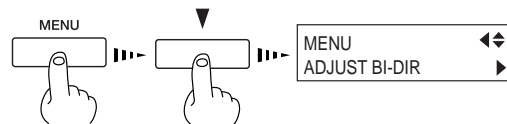

- 2 Press the [▶] key to make the following screen appear on the display.

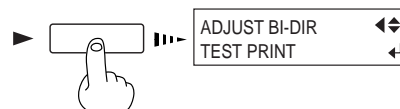

- 3 Press the [ENTER] key to start printing a test pattern.

After the printing test has finished, the media is fed to a position that lets you to view the test pattern.

- 4 Check the test pattern and choose adjustment value (a value with no displacement).

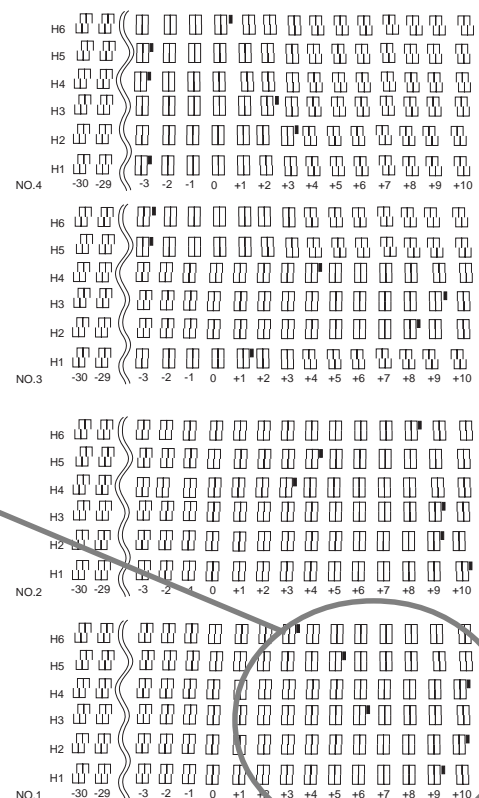
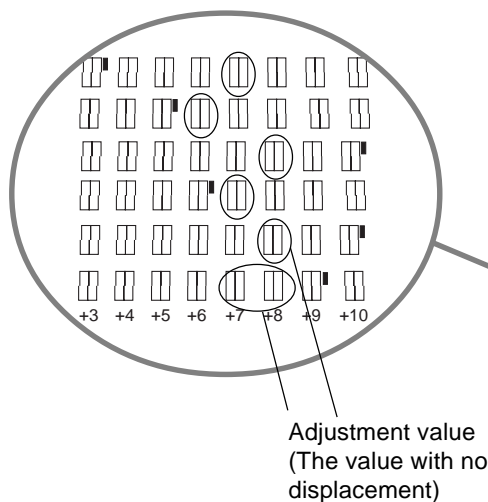

- 5 Check the adjustment value, then press the [ENTER] key.  
The media returns to its position when the printing test ended.



**6** Press the [▼] key to make the following screen appear on the display.

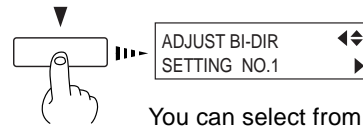

You can select from SETTING NO. 1 through SETTING NO. 4.

**7** Press the [▶] key to make the following screen appear on the display.

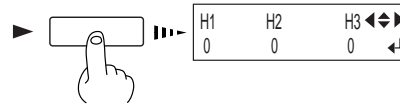

**8** Use the [◀], [▶], [▲] and [▼] keys to set the value you checked in step 4, then press the [ENTER] key.

In case of [SETTING NO.1], enter H1=71/2, H2=8, H3=7, H4=8, H5=6, and H6=7.

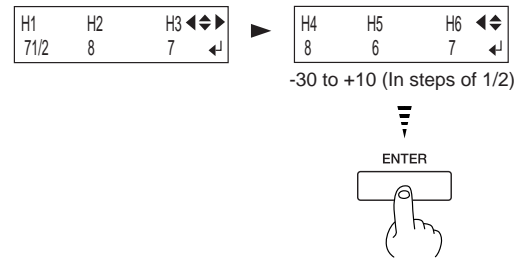

**9** Use the [▲] and [▼] keys to Choose "Setting No.2". [SETTING NO. 2] appears. In the same way as in step 6 and step 8, enter the value you checked in step 4, then press the [ENTER] key.

Enter values in the same way for [SETTING NO. 3] and [SETTING NO. 4].

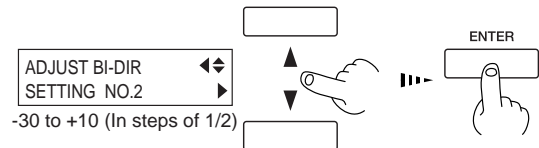

## Saving and Loading a Bidirectional-correction Value

You can take adjustment values for bidirectional correction that you've set and save them in memory. You can save up to eight types.

Saving different adjustment values for different types of media lets you load the adjustment value simply and easily when you change the media type.

### Saving an Adjustment Value

**1** Follow the steps in the previous section, "Setting Adjustment Value," to enter adjustment values for [SETTING NO. 1] through [SETTING NO. 4].

**2** Press the [▼] key to make the following screen appear on the display.



**3** Press the [▶] key to display the screen shown in the figure. Choose a number to save to from among [PRESETTING 1] through [PRESETTING 8], then press the [ENTER] key.



The adjustment values are saved in the memory number you selected.

#### Point

It may be a good idea to keep notes of the memory numbers and the kind of media whose adjustment value is saved in each number

## Loading an Adjustment Value

**1** Press the [MENU] key and [▼] key to make the following screen appear on the display.

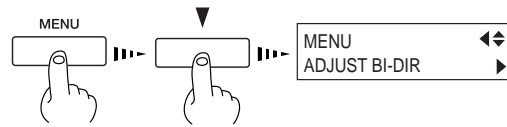

**2** Press the [▶] key to make the following screen appear on the display.

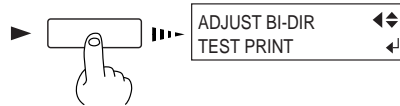

**3** Press the [▼] key to make the following screen appear on the display.



**4** Press the [▶] key to display the screen shown in the figure.



Choose the memory number to load, then press the [ENTER] key.

The selected adjustment value is loaded.



### Point

This operation deletes adjustment values that are not saved in memory. If there are adjustment values that you want to keep, save them in memory first.

# 3-7 Stopping Printing Operations

## Stopping Printing Operations

### Stopping Printing

- 1 Press the [PAUSE] key.
- 2 Halt transmission of printing instructions from the computer.
- 3 Hold down the [SETUP] key for one second or longer. Any remaining data is cleared.

The PAUSE LED lights up

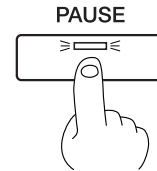

The SETUP LED flashes

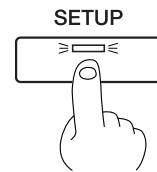

## Pausing Printing Operations

Press the [PAUSE] key. The PAUSE LED lights up.

The PAUSE LED lights up

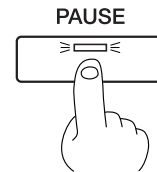

### To resume printing

Press the [PAUSE] key again. The PAUSE LED goes out.

The PAUSE LED goes out

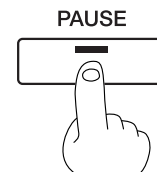

## 3-8 Changing the Type of Ink

When changing the type of ink in use, follow the steps below to replace the ink.

Ink replacement requires four optionally available cleaning cartridges. You can perform cleaning three times per cleaning cartridge.

- 1 Press the [MENU] key and [▼] key to make the following screen appear on the display.

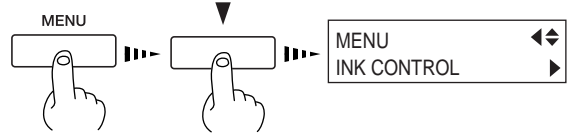

- 2 Press the [▶] key to make the following screen appear on the display.



- 3 Use the [▼] key to select [CHANGE INK SET], then press the [▶] key.

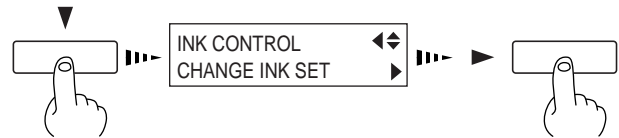

- 4 Use the [▲] and [▼] keys to select the new type of ink to use, then press the [ENTER] key.

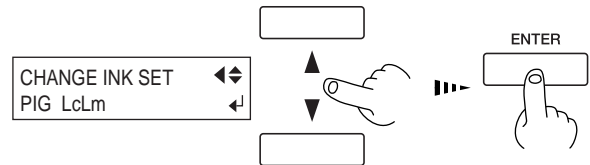

- PIG LcLm: Pigmented ink  
(cyan, magenta, yellow, black, light cyan, light magenta)
- PIG OrGr: Pigmented ink  
(cyan, magenta, yellow, black, orange, green)
- DYE LcLm: Dye-based ink  
(cyan, magenta, yellow, black, light cyan, light magenta)

- 5 When the display shown in the figure appears, discard the discharged ink in the drain bottle.



### Point

Be sure to discard the discharged ink. Attempting to replace the ink while discharged ink remains may cause discharged ink to overflow from the bottle.

Continued on the next page

- 6** Attach the drain bottle and press the [ENTER] key. The display shown in the figure appears.

```
REMOVE CARTRIDGE
1 2 3 4 5 6 7 8 9 10 11 12
```

In the example shown above, LcLm pigment inks are being changed to OrGr pigment inks.

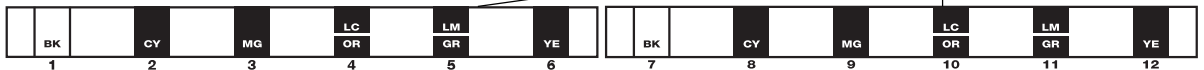
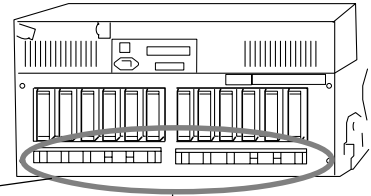

- 7** Pulling out all the ink cartridges starts the replacement of ink. Follow the messages on the display to carry out the procedure.

Messages appearing during ink replacement

```
SET CL - LIQUID
1 2 3 4 5 6 7 8 9 10 11 12
```

Insert a cleaning cartridge into the ink cartridge port for the flashing number.

- 8** When the display shown in the figure appears, discard the discharged ink in the drain bottle.

```
EMPTY
DRAIN BOTTLE
```

**Point**

Be sure to discard the discharged ink. Attempting to replace the ink while discharged ink remains may cause discharged ink to overflow from the bottle. For more information about how to dispose of discharged ink, see "4-5 Disposing of Discharged Ink".

- 9** When the display shown in the figure appears, insert the ink cartridge to be newly used.

```
SET CARTRIDGE
123456789101112
```

- 10** When the display shown in the figure appears, ink replacement is finished. Press the [SETUP] key to go back to the top menu.

```
CHANGE INK SET
PIG OrGr
```

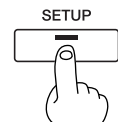

## 3-9 When Not in Use for a Prolonged Period



**When not in use for extended periods, unplug the power cord from the electrical outlet.**

Failure to do so may result in danger of shock, electrocution, or fire due to deterioration of the electrical insulation.



**When unplugging the electrical power cord from the power outlet, grasp the plug, not the cord.**

Unplugging by pulling the cord may damage it, leading to fire or electrocution.

**1** Press and hold down the [POWER] key for one second or longer to switch off the sub power.

**2** Turn off the main power switch.



### **Notice**

Do not try to switch off the main power or unplug the power cord before you switch off the sub power.

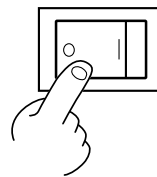

Switch to "O"

**3** Unplug the power cord from the electrical outlet.

### **If the unit will be out of use for a month or longer**

If the unit will be out of use for a month or longer, follow "4-7 When Moving the Unit" to wash the printing head. Head washing requires four optionally available cleaning cartridges.

# ***4. Maintenance***

---

This section describes how to clean the printing heads, daily care and maintenance, and the like.

# 4-1 Cleaning the Printing Heads

Switching on the sub power automatically performs maintenance operations, including cleaning of the printing head. This means that there is normally no need to perform cleaning otherwise. If drop-out occurs with printed images, clean the printing head.

## Cleaning the Printing Heads

- 1 Load media for printing-test use.
- 2 Pressing the [CLEANING] key lets you select cleaning of all the heads or of only the A group heads, the B group heads, or the C group heads.

Press the [ENTER] key to start head cleaning. Also, holding down the [CLEANING] key for at least one second starts head cleaning for all heads.

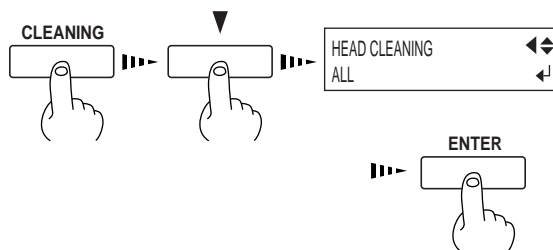

### Point

#### Printing-head Groups

A Group : Black, Cyan

B Group : Magenta, Yellow

C Group : Light cyan, Light magenta, or Orange, Green

- 3 After head cleaning has ended, holding down the [TEST PRINT] key for one second or longer starts a printing test.



- 4 Refer to "2-3 Printing -- Performing a Printing Test" and check the printing-test results. If a problem is found, repeat the cleaning.



## If Drop-out Persists Even After Carrying Out Cleaning Several Times

### Point

Perform head cleaning only when there is dot drop-out (gaps) or printing becomes faint. Performing head cleaning more than necessary subjects the heads to wear and consumes ink. In particular, cleaning performed at the [POWERFUL] menu for [HEAD CLEANING] can cause premature head wear and consume large amounts of ink. (Performing cleaning at the [POWERFUL] consumes approximately 60 cc of ink for each group.)

- 1 Load media for printing-test use.
- 2 Press the [MENU] key and [▼] key to make the following screen appear on the display.

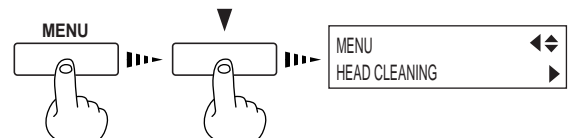

- 3 Press the [▶] key and the [▼] key to display the screen shown in the figure. You can choose to perform cleaning of only the A group heads, B group heads, C group heads or only the left head by pressing the [▼] key more times. Press the [ENTER] key to start head cleaning ("medium").

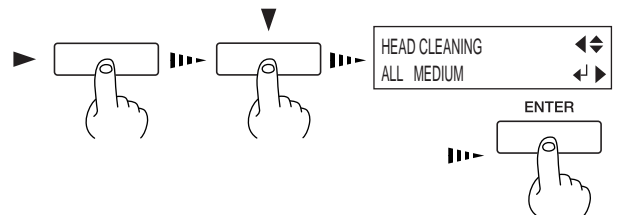

- 4 When head cleaning finishes, perform a print-test to check the results.

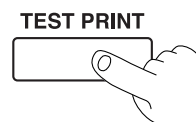

## If Performing POWERFUL Cleaning Several Times Does Not Correct the Drop-out Problem

If performing cleaning several times at the [POWERFUL] menu does not correct the image drop-out problem, use the included cleaning kit. For information on how to use the cleaning kit, refer to the following section, "Using the Cleaning Kit to Clean the Printing Heads."

# 4-2 Cleaning Using the Cleaning Kit

Cleaning using the cleaning kit should be carried out when automatic cleaning and forced cleaning from the [HEAD CLEANING] menu fail to correct image drop-out. Remove any ink buildup or dust or grime around the printing heads, which can cause image drop-out or ink drips. We also recommend performing periodic cleaning using the cleaning kit to prevent problems like these during printing.

If image drop-out persists even after performing cleaning with the cleaning kit, or if the cleaning kit is used up, contact your authorized Roland DG Corp. dealer or Roland DG Corp. service center.

The heads are consumable parts. The useful life is six billion shots per nozzle.

## Notice

Before starting cleaning, read through this section carefully to familiarize yourself with the procedures, then carry out the cleaning operations quickly and accurately.

Cleaning is performed while the caps on the printing heads are detached, so cleaning must be completed before the heads dry out. It is suggested that cleaning be completed in thirty minutes or less.

If it appears that cleaning operations may take more than thirty minutes, stop the cleaning operations and follow the steps below.

1. Attach the cover and tighten the screws.
2. Press the [ENTER] key. (Cleaning of the printing heads starts.)
3. Again carry out cleaning using the cleaning kit.

## Cleaning Using the Cleaning Kit

- 1** Switch on the main power switch on the back of the machine.

Leave media unloaded at this time.

- 2** While holding down the [CLEANING] key, switch on the [POWER] key.

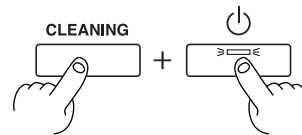

- 3** Press the [▲] and [▼] keys to select [CLEANING].



- 4** Press the [ENTER] key.

The screen shown in the figure appears, and the printing carriage moves to the middle of the left cover

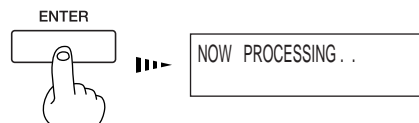

- 5** Make sure the screen shown in the figure is displayed, then remove the four screws and open the left and right covers.



## Notice

Take care not to drop the covers when removing them. If dropped, the impact may cause them to break.

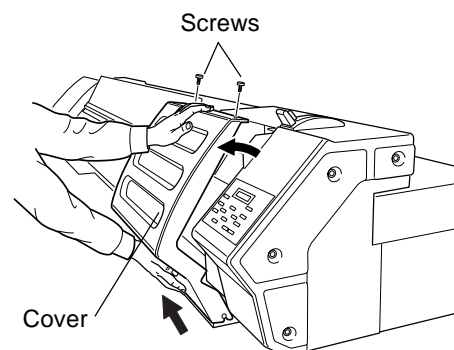

- 6** To discharge static electricity from your body, touch the location shown in the figure.

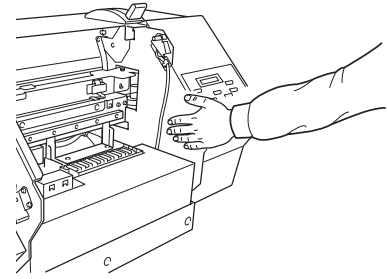

- 7** Clean the heads and the area around the heads on the left side of the machine. Use a cleaning stick to wipe off any grime from the stainless-steel frame for the heads and the plastic areas on either side of the heads.

**! Notice**

Be sure to use one of the included cleaning sticks.  
Do not touch the nozzle surface of the heads.

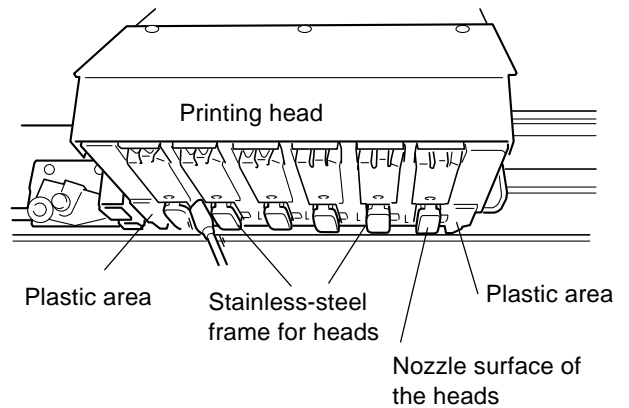

- 8** Clean the surface of the stainless-steel frame on the right side of the machine. Use a cleaning stick to wipe away any buildup of dust and ink from the surface of the stainless-steel frame. If there is dust on the sponges, wipe it off with the cleaning stick.

**💡 Point**

Give special attention to removing the fibrous dust that tends to build up on the heads.

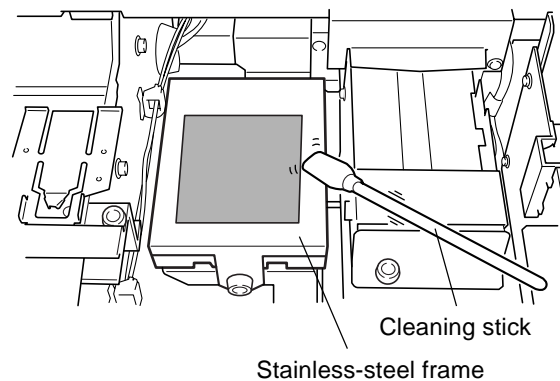

- 9** Clean the rubber caps and the area around them. Use a cleaning stick to wipe off any buildup of dust or grime from the rubber caps. If there is dust on the sponges, wipe it off with the cleaning stick.

**! Notice**

If no grime is present, do not touch the sponges inside the rubber caps.

When removing grime adhering to the sponge inside a rubber cap, touch the sponge gently with the tip of the cleaning stick to pick up the grime. Rubbing forcefully may damage the surface of the sponge.

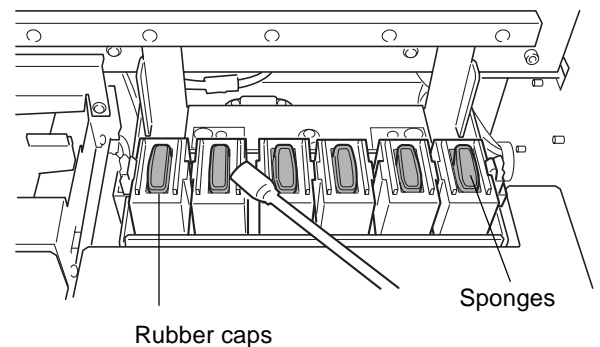

- 10** Clean the wiper. Use a cleaning stick to wipe away any buildup of dust and grime from the wiper.

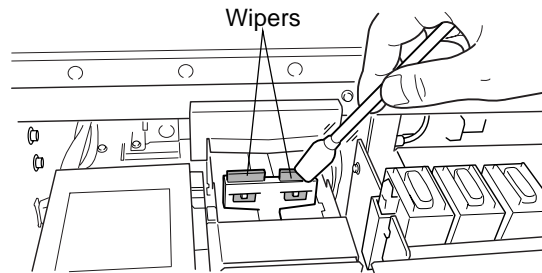

**Point**

**Replacing the Wiper**

If the message [REPLACE WIPER] appears on the display, replace the wiper with a new one. As a rule of thumb, the message prompting you to replace the wiper appears when cleaning has been performed 500 times (with [ALL] selected for head cleaning). For information on how to replace the wiper, see "4-3 Replacing the Wiper."

- 11** Attach the left and right covers and secure them closed by tightening the screws.

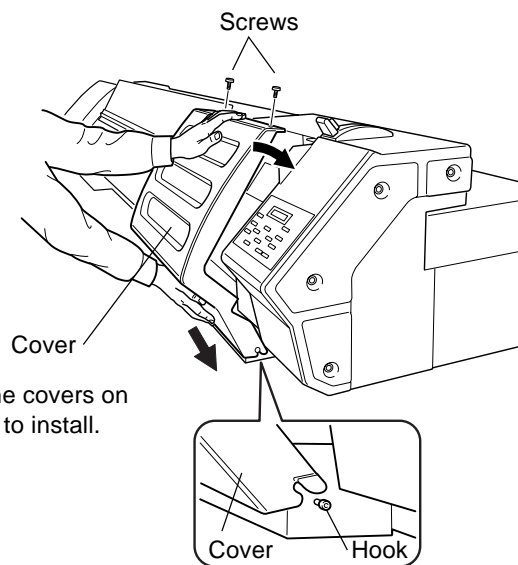

- 12** Press the [ENTER] key.

The screen shown in the figure appears, the printing heads return to the standby position, and head cleaning starts automatically. After cleaning has finished, switch off the sub power.

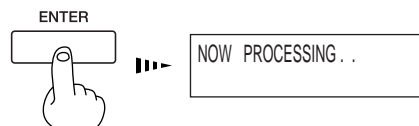

- 13** Again press the [POWER] key to switch on the sub power, load media, and carry out a printing test.

Examine the results of the printing test and make sure that all dots are printed attractively. If necessary perform head cleaning to make the dots clean and even.

# 4-3 Replacing the Wiper

If the message shown in the figure appears, replace the wiper with a new part.

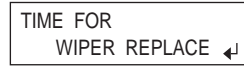

- 1 Follow steps 1 through 3 in "4-2 Cleaning Using the Cleaning Kit" to display the screen shown in the figure.
- 2 Follow steps 4 through 6 in "4-2 Cleaning Using the Cleaning Kit" to detach the right cover, and discharge static electricity from your body.
- 3 Using tweezers, grasp the bottom portion of the wiper and take it off the hook.



- 4 Remove the wiper and install the new one.



### Point

The wiper has a rubber surface and a felt surface. Attach it so that the rubber surface faces the front.

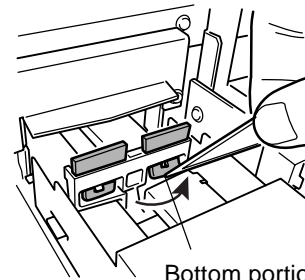

Bottom portion of the wiper

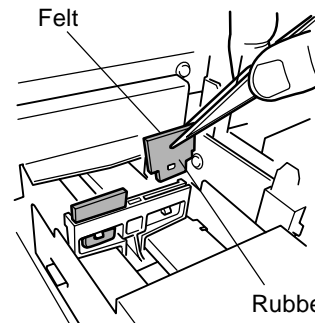

Rubber

- 5 Use the tweezers to press the area shown in the figure and engage the wiper on the hook.



### Notice

When installing the wiper, be sure to engage it on the hook. If the wiper is not hooked, it may fall off during use. Use the included tweezers to install and detach the wiper.

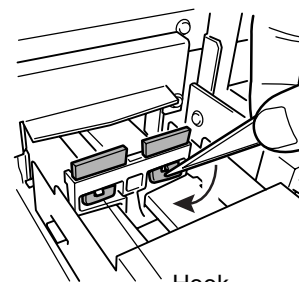

Hook

- 6 Follow steps 11 through 13 in "4-2 Cleaning Using the Cleaning Kit" to attach the right cover and carry out a printing test.

## 4-4 Other Cleaning Tasks

The machine and the inside of the front cover may become soiled with ink during printing. The cleaning methods described below let you continue printing without affecting the printed media or the machine.

### **Notice**

- When carrying out any cleaning other than cleaning using cleaning sticks, switch off the main power. Before turning off the main power, press the [POWER] key to switch off the sub power.
- Never lubricate the mechanisms.
- Do not clean with solvents (such as benzine or thinners).
- Periodically clean the platen, grit rollers, reflective tape, and media clamps. Buildup of grime may soil printed media and make correct detection of media width impossible.
- Do not touch the printing heads or allow the printing heads to come in contact with anything except ink.

### **Cleaning the Body**

Use a cloth moistened with water then wrung well, and wipe gently to clean. Wipe the operation panel and display gently with a clean, soft cloth.

### **Cleaning the Platen**

Moisten a cloth with neutral detergent diluted with water, wring dry, and wipe gently. For buildup of cutting dust on the platen, use a commercially available brush to brush them away toward the front. When doing this, do not use a metal brush.

### **Cleaning the Grit Rollers**

Use a commercially available brush to remove dust and other detritus. Any adhering grime may prevent the media from being held in place securely.

### **Cleaning the Pinch Rollers**

Use a cloth moistened with water then wrung well, and wipe gently to clean.

### **Cleaning the Reflective Tape**

If the tape becomes dirty, moisten a cloth with neutral detergent diluted with water, wring dry, and wipe gently.

### **Cleaning the Front Cover**

Use a cloth moistened with water then wrung well, and wipe gently to clean.

### **Cleaning the Media Clamps**

If there is buildup of ink or dust, moisten a cloth with neutral detergent diluted with water, wring dry, and gently wipe the surface.

# 4-5 Disposing of Discharged Ink

The bottle stand for the drain bottle is provided with a window to help determine when discharged ink needs to be disposed.

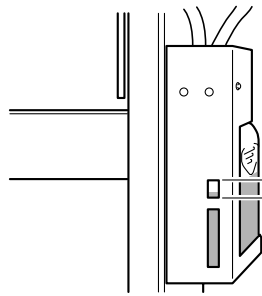

When the discharged ink is within this range, dispose of it.  
If discharged ink is allowed to exceed this range, it may spill when the bottle is removed.

Dispose of ink in the drain bottle as described below.

## Procedure for Disposing of Discharged Ink

- 1 Press the [POWER] key at least one second to switch off the sub power.

The POWER LED goes out

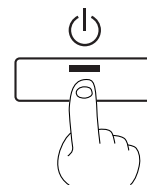

- 2 Remove the drain bottle.

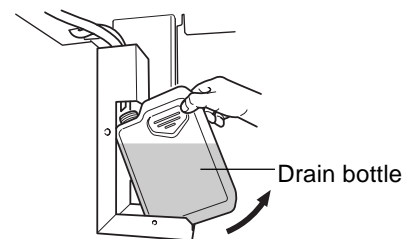

- 3 Put a water-absorbent, combustible media such as a paper or cloth into the plastic bag, and soak the ink.

Combustible media such as a paper or cloth



- 4 Dispose of it as combustible media impregnated with discharged ink.



### Point

If any ink gets on your hands or clothing, wash it off as soon as possible. Ink stains may become difficult to remove if allowed to stand.

# 4-6 How to Replace the Separating Knife



**Do not touch the tip of the separating knife with your fingers.**  
Doing so may result in injury.



**Do not touch the control panel while head cleaning or other cleaning is in progress.**  
The printing carriage may move and cause injury.



## Notice

When replacing the knife, do not pull out the printing carriage.  
If the machine is allowed to stand for a prolonged period with the printing carriage pulled out, head clogging or even damage to the printing heads may occur.

If the separating knife becomes dull, replace with the included replacement blade.

- 1 Press the [MENU] key and [▼] key to make the following screen appear on the display.

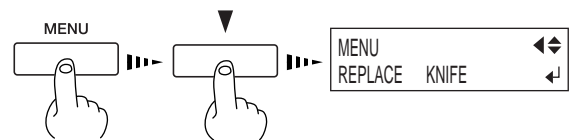

- 2 Press the [ENTER] key to make the following screen appear on the display.

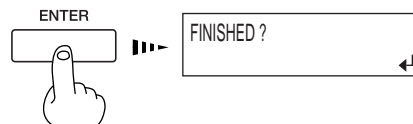

When the screen shown in the figure appears, the printing carriage simultaneously moves to the left.

- 3 Open the front cover, and then remove the separating knife.



## Point

If a blade remains in the printing carriage, use the tweezers in the cleaning kit to remove it.

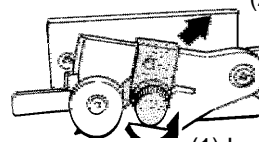

- (2) Grasp the screw portion, and slowly pull it out in the direction of the arrow.

- (1) Loosen the screw until it slips out.

- 4 Replace with a new knife.

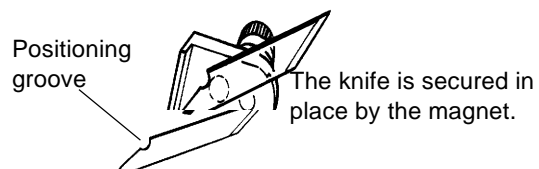

- 5 Install the separating knife.

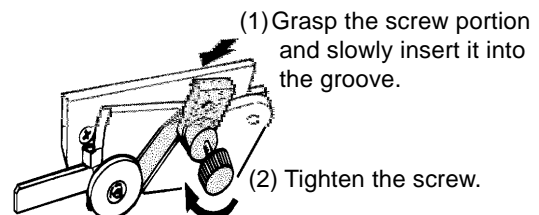

- 6 Close the front cover and press [ENTER] key.



# 4-7 When Moving the Unit

## ! Notice

Before attempting to move the machine, clean the heads. Four optionally available cleaning cartridges are required to clean all the heads. Each cleaning cartridge can be used to perform cleaning three times.

Do not tilt the machine at a large angle. Ink or discharged fluid remaining in the machine may leak or spill, causing breakdown or malfunction.

**1** If there is media loaded, hold down the [SETUP] key for 1 second or longer to cancel setup, then remove the media (see "2-2 Loading Media -- Removing the Media").

**2** Press the [MENU] key and [▼] key to make the following screen appear on the display.

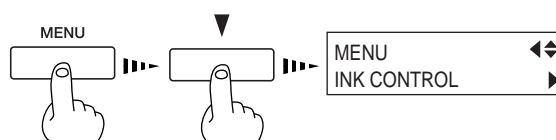

**3** Press the [▶] key to make the following screen appear on the display.



**4** Use the [▼] key to select [HEAD WASH], then press the [ENTER] key.



**5** When the display shown in the figure appears, discard the discharged ink in the drain bottle.



## ! Notice

Be sure to discard the discharged ink. Attempting to clean the heads while discharged ink remains may cause discharged ink to overflow from the bottle. For more information about how to dispose of discharged ink, see "4-5 Disposing of Discharged Ink."

**6** Mount the drain bottle and press the [ENTER] key to display the screen shown in the figure.



- 7** After you have pulled out all the ink cartridges whose colors are flashing, head cleaning starts. Follow the messages on the display to carry out the procedure.

When cleaning for the first two colors finishes, the display returns to the screen shown in step 6. Follow the messages on the display to perform cleaning for the remaining four colors.

Insert a cleaning cartridge into the ink cartridge port for the flashing number.

SET	CL-LIQUID										
1	2	3	4	5	6	7	8	9	10	11	12

- 8** When head cleaning finishes, the sub power shuts of automatically.

Switch off the main power switch.

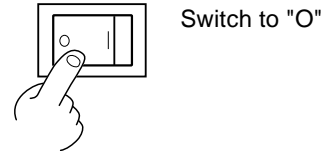

- 9** Detach the power cord and the cable connecting the unit to the computer.

- 10** Remove the drain bottle and stopper the drain tube.

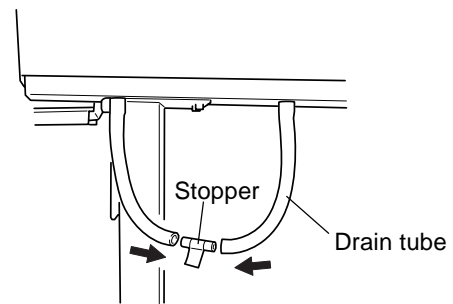

- 11** Secure the printing carriage in place.  
For information on how to secure in place, refer to "1-3 Assembling and Installing -- Step 4: Remove the Protective Media."

# ***5. Menus and Keys***

---

This section contains a flowchart of the menus and describes the control-panel keys and the menu items.

# 5-1 Display Menu Flowchart

For details about each of the menus, see the "5-2 Description of Menus."

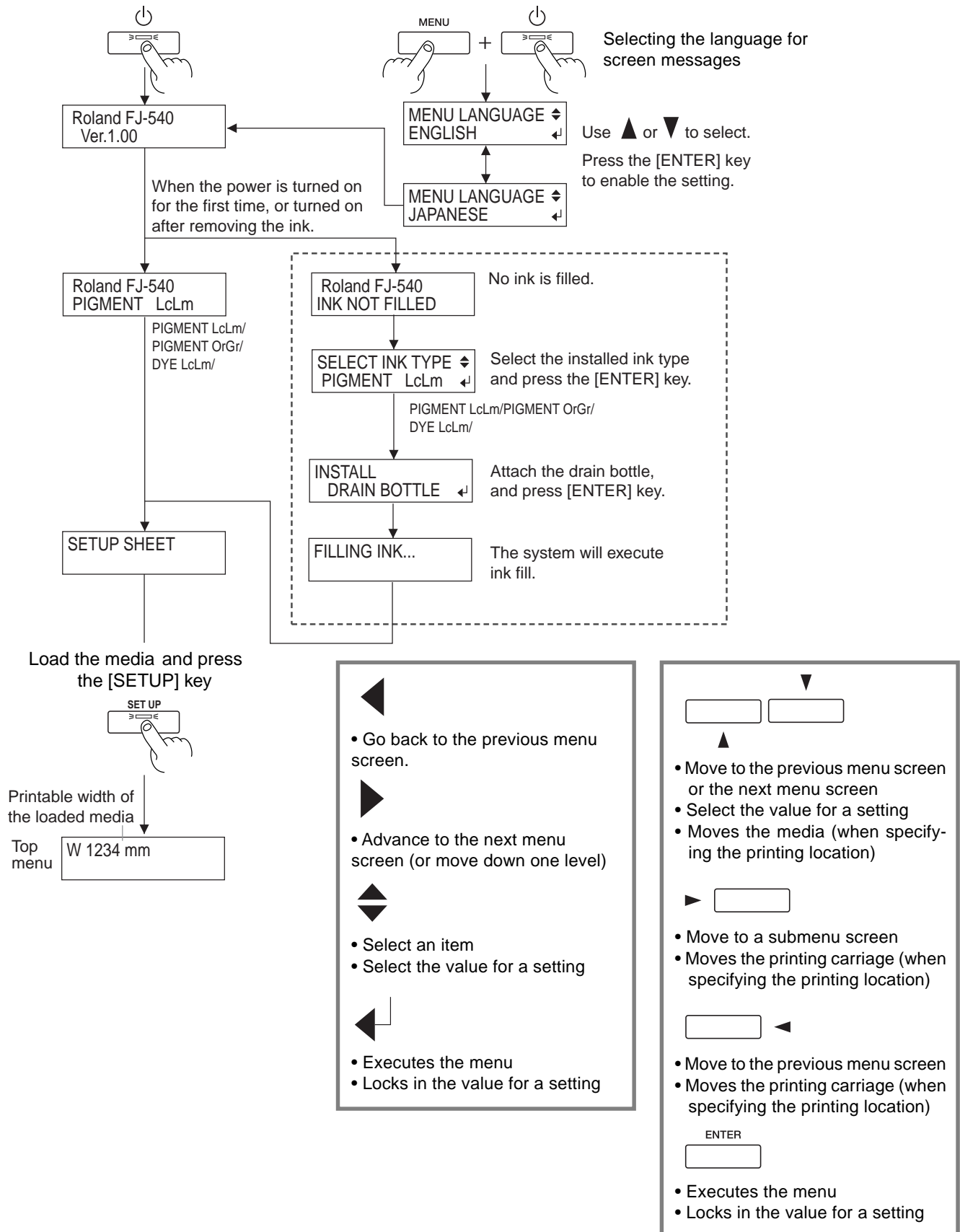

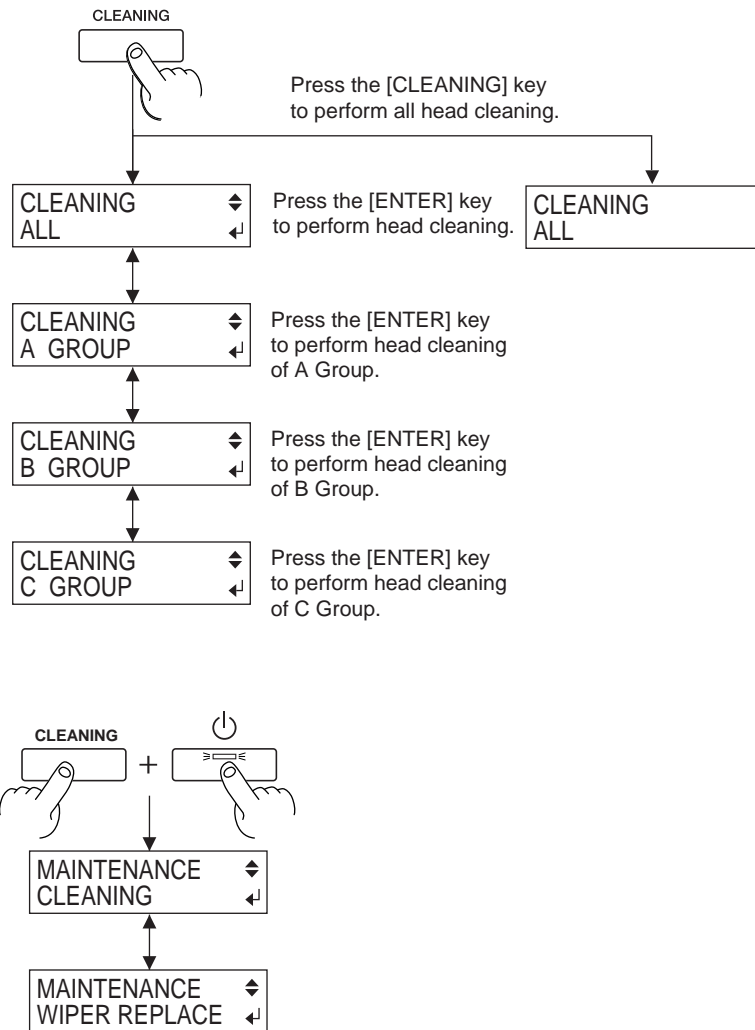

## 5-1 Display Menu Flowchart

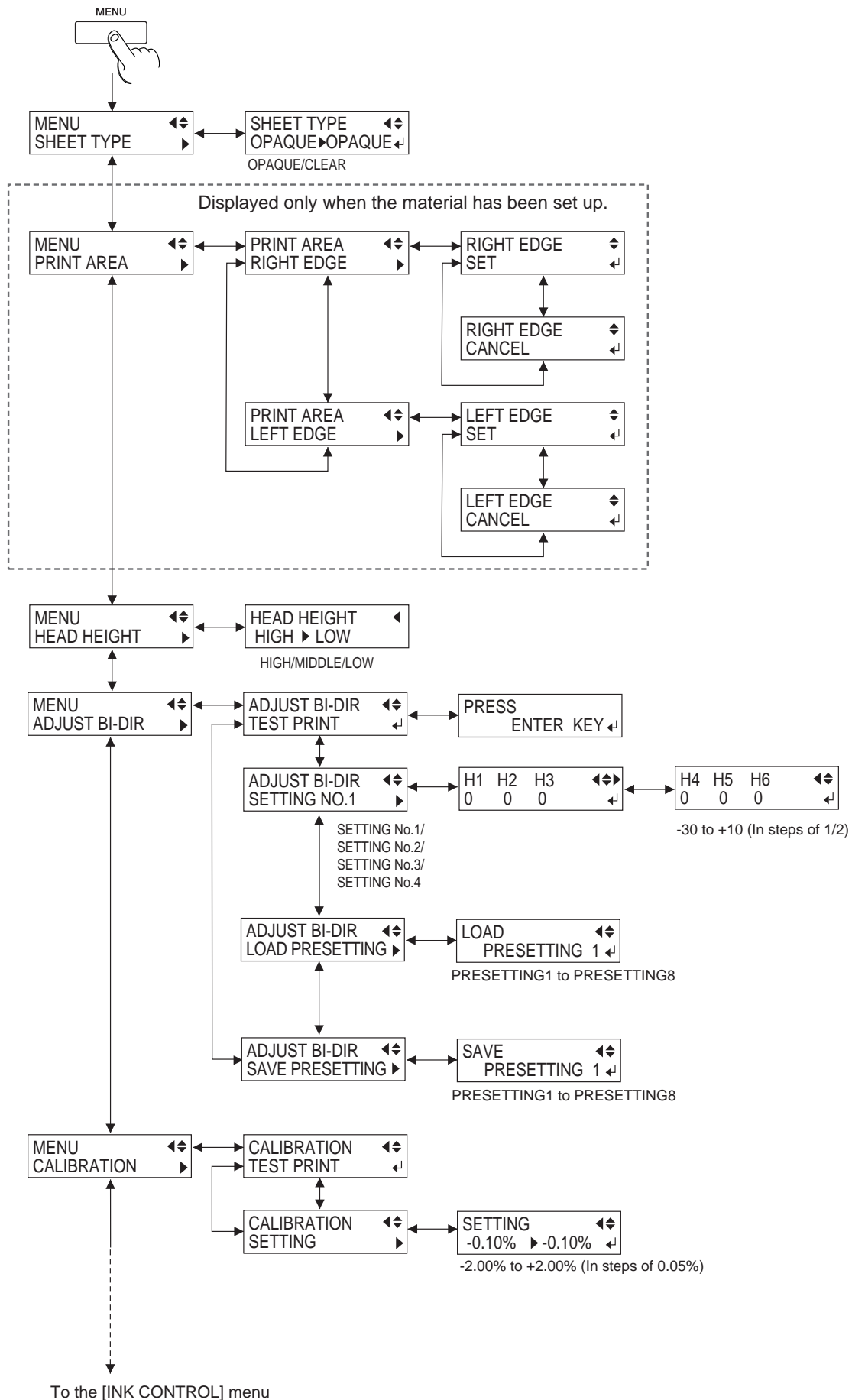

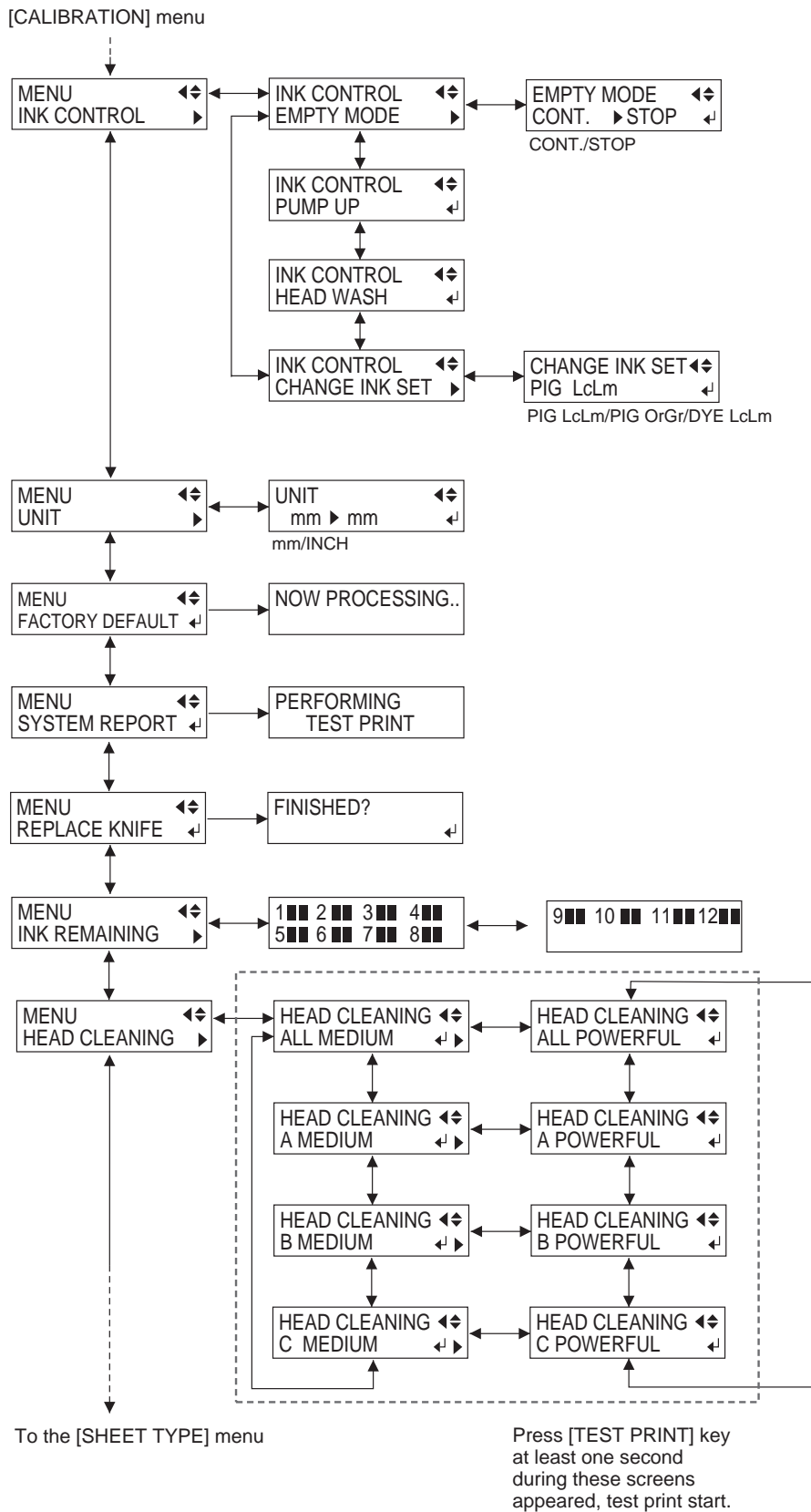

## 5-2 Description of Menus

Top menu	Submenu	Function	Setting range	Default value
SHEET TYPE	—	This is used to select either transparent or opaque media. Select [OPAQUE] when the media loaded on the unit is not transparent. When the media loaded on the unit is not transparent, select [OPAQUE]. When you are using transparent media or the printing area cannot be detected, select [CLEAR]. For more information, see "3-5 Using Transparent Media."	OPAQUE/ CLEAR	OPAQUE
PRINT AREA	RIGHT EDGE  LEFT EDGE	* This appears only when the media is in a loaded state.  This sets the printing area in the left-right direction (the direction of printing carriage movement) of the loaded media. With transparent media, automatic detection of the media width is not performed. In such cases, use the [PRINT AREA] menu to specify the printing area in the left-right direction. Even when using opaque media, this can be specified when printing in a specific area. For more information, see "3-3 Setting the Location Where Printing Starts -- Specifying a location in the feed direction."	—	—
HEAD HEIGHT		This sets the height of the printing heads. To make the setting, display this menu, then move the lever on the side of the unit's printing carriage. For more information, see "2-2 Loading Media -- When Loading Thick Media ."	H I G H / M I D D L E / L O W	MIDDLE
HEAD CLEANING	ALL MEDIUM A MEDIUM B MEDIUM C MEDIUM  ALL POWERFUL A POWERFUL B POWERFUL C POWERFUL	If print shows a problem, clean the printing head. Because cleaning subjects the head to wear and consumes ink, it should only be performed when absolutely necessary. Performing cleaning from the Powerful menu in particular subjects the head to early wear and used up large amounts of ink. [ALL MEDIUM]/[A MEDIUM]/[B MEDIUM]/[C MEDIUM]: Performs cleaning of the printing heads. After cleaning, carry out a printing test to make sure there are no problems with printing quality. Normally, head cleaning should be performed by pressing the [CLEANING] key. [ALL POWERFUL]/[A POWERFUL]/[B POWERFUL]/[C POWERFUL]: Used when performing cleaning with Medium several times does not restore the printing quality. After cleaning, carry out a printing test to make sure there are no problems with printing quality. For more information, see "2-3 Printing -- Performing a Printing Test" and "4-1 Cleaning the Printing Heads."	—	—











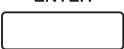
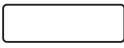
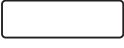

## 5-2 Description of Menus

Top menu	Submenu	Function	Setting range	Default value
UNIT	—	This selects millimeters or inches as the unit of measurement for the width displayed on the top menu after setting up the media. When inch display is used, values are displayed to the first digit to the right of the decimal point.	mm/INCH	mm
SYSTEM REPORT	—	This prints the current status of settings and other system information.	—	—
REPLACE KNIFE	—	This prompts you to replace the separating knife.	—	—
FACTORY DE-FAULT	—	This returns all menu settings to their original values when shipped from the factory. For more about the factory defaults for the various settings, see the "Default value" entry for each menu setting in this section.	—	—
INK REMAINING	—	This shows the amount of ink left after each of the ink cartridges has been installed. The fewer the markers ("■"), the less ink is left.  * If a partially used ink cartridge is removed and reinstalled, or if a partially used ink cartridge is installed, the cartridge is taken to be unused, and the displayed amount of remaining ink is not true. For more information, see "3-2 Checking the Remaining Ink Level."	—	—

## 5-3 Description of Keys

Key	Top menu	Function	Setting range	Default value
	—	This switches on and off the sub power . When the power is switched on, the POWER LED lights up.	—	—
SETUP 	—	This detects the presence and the width of the media, and displays the printable width. The SETUP LED flashes while detection of media width is in progress. When setup finishes, the SETUP LED lights up continuously. Also press this key when removing the media. Pressing this key when any of the various menu screens is displayed returns you to the top screen. (When this is done, media setup cannot be canceled.)	—	—
PAUSE 	—	The [PAUSE] key pauses printing. The PAUSE LED lights up while paused. Pressing this key again cancels the paused state. Holding down the [SETUP] key for about 1 second while paused causes remaining data to be cleared and cancels the media's setup state.	—	—
BASE POINT 	—	This sets the print-start location in the scan direction (the direction of printing carriage movement). For more information, see "3-3 Setting the Location Where Printing Starts -- Specifying a location in the scan direction."	—	—
ENTER 	—	This is used to accept, execute, or save the item shown on the display.	—	—
TEST PRINT 	—	Holding down the [TEST PRINT] key for one second or longer while the SETUP LED is lit performs a printing test.	—	—
CLEANING 	—	This enters the [HEAD CLEANING] menu for cleaning the printing heads.  Cleaning can be performed while in any state. [ALL], [A GROUP], [B GROUP], or [C GROUP]: Begins cleaning of the printing heads. Holding down for one second carries out cleaning for all the heads. After cleaning, carry out a printing test to make sure there are no problems. For detailed information, see "2-3 Printing -- Performing a Printing Test" and "4-1 Cleaning the Printing Heads."	—	—

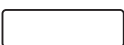
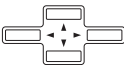
## 5-3 Description of Keys

Key	Top menu	Function	Setting range	Default value
SHEET CUT 	—	Pressing and holding the [SHEET CUT] key for one second or longer cuts off the media at the location of the present print-start line. Press this to separate the portion that has been printed from the roll. You cannot sever a piece of media while printing is in progress.	—	—
MENU 	—	This enters the menu mode. When a menu is displayed, the [▲] and [▼] keys move to the next menu, the [▶] moves to a submenu, and the [◀] key moves to the previous screen.	—	—
	—	These move the media and the cartridge. When a menu is displayed, these move among the menu items.	—	—
MENU  + 	LANGUAGE	This sets the language for screen messages. You can select either English or Japanese.	ENGLISH/JAPANESE	ENGLISH

## ***6. What to Do If...***

---

This section describes error messages that may appear on the display and how to resolve problems that can occur during operation.

# 6-1 What to Do If...

## The machine doesn't run

### The power does not switch on.

#### Is the main power switched on?

If the power does not come on when you press the [POWER] key, the main power at the back of the machine may not be switched on. Make sure the main power is switched on, then press the [POWER] key again.

### Printing doesn't start when data is sent.

#### Are the network settings correct?

Make sure there are no errors in the network settings. For more about making the connection to a network, see "Roland PrintServer Network Settings Guide."

#### Has media been loaded (the SETUP LED is lit)?

If the SETUP LED is not illuminated, make sure the media is loaded correctly and press the [SETUP] key to illuminate the SETUP LED.

#### Is the top menu displayed?

If the top menu isn't displayed, printing doesn't start even when data is sent from the computer.

#### Top menu

W 1234 mm

#### Is the PAUSE LED illuminated?

If the [PAUSE] key has been pressed and the PAUSE LED is lighted, the unit has been paused.

To resume printing, press the [PAUSE] key again. The PAUSE LED is extinguished, and printing resumes.

To terminate printing, first stop the transmission of printing instructions from the computer to this machine. Then press the [SETUP] key. Hold down for about 1 second. This deletes the printing instructions that have already been sent from the computer to this machine, and printing is stopped.

#### Has ink run out?

When printing data is sent while the screen shown in the figure is displayed, a message appears and a warning beep sounds.

At the same time, operation pauses. When the ink cartridge is replaced with a new one, printing starts.

1	2	3	4	5	6
7	8	9	10	11	12

This screen show 1 and 7 is run out.

## ■ The media width cannot be detected, even when the [SETUP] key is pressed.

### Is [SHEET TYPE] set to [CLEAR]?

When [SHEET TYPE] is set to [CLEAR], the width of the media is not detected during media setup (and the printable width is set to maximum).

When transparent media is loaded, specify a printing area that matches the actual width of the media. (Refer to "3-5 Using Transparent Media")

If opaque media is loaded, set [SHEET TYPE] to [OPAQUE].

### Is the width of the loaded media 210 mm or less?

When media having a width of 210 mm or less is loaded, the width is not detected during media setup. Load media that is at least 210 mm wide and perform setup again.

## Clean, attractive printing is impossible

### ■ If drop-out occurs with printed images.

Clean the printing heads (see "4-1 Cleaning the Printing Heads").

### ■ The printing heads scrape the surface of the media.

#### Is the loaded media very thick?

If media feed is not smooth because the media catches on the head, then adjust the height of the printing heads (see "2-2 Loading Media -- When Loading Thick Media").

When the height of the printing head has been adjusted, it is necessary to perform bidirectional correction. For more information about bidirectional correction, see "3-6 Making Corrections for Printing -- Bidirectional Correction"

If you are using media that becomes uneven when printed, then perform unidirectional printing. With unidirectional printing, unevenness is less conspicuous than bidirectional printing.

Also, if the printing heads scrape the media even when the heads are raised, then do not use that media.

Doing so may not only cause paper jams, but may soil the media (the printing surface) and impair printing accuracy.

### ■ The results of printing are coarse.

#### Has feed correction been performed?

Correcting the amount of feed improves the dot-positioning accuracy in the feed direction, which can help enhance image quality.

If the type of media was changed, refer to "3-6 Making Corrections for Printing -- Feed Correction" and perform correction for feed.

#### Has bidirectional correction been performed?

If misalignment like in the example occurs when performing bidirectional printing, then carry out correction at the [BIDIRECTION] menu (see "3-6 Making Corrections for Printing -- Bidirectional Correction").

Be sure to make this setting when you have replaced the media with a different type, or if you have adjusted the head height and printing is misaligned.

[EXAMPLE]



OK: Correct



Not OK: Single lines not produced

## **The printing length is not accurate**

### **Is the loaded media very thick?**

To correct the amount of feed, refer to "3-6 Making Corrections for Printing -- Feed Correction" and make the correction to match the media you're using.

## **During printing, ink drips from the printing carriage and soils the media (the printing surface)**

The following may cause ink to drip on the media during printing.

- Dust or fiber-containing grime around the heads may have absorbed ink.
- The heads scraping the media may have caused ink to fail to be discharged, resulting in ink buildup in the heads.

If this happens, refer to "4-2 Using the Cleaning Kit to Clean the Printing Heads" and clean the heads.

We recommend carrying out periodic head cleaning.

Also, before you start printing, perform a printing test to make sure there is no dot drop-out.

## **Printing goes beyond the loaded media**

### **Is the reflective tape dirty?**

If the reflective tape becomes soiled, the width of the media cannot be detected correctly. If the tape becomes dirty, moisten a cloth with neutral detergent diluted with water, wring dry, and wipe gently.

### **Has the media been loaded at an angle?**

If the loaded media is not straight, it may extend outside the printing area.

Refer to "2-2 Loading Media" and load the media correctly.

### **Has the printing area been set to fill the media entirely?**

When setting the printing area in the scan direction (the direction of printing carriage movement) at the [PRINT AREA] menu, leave a margin on either side. If the printing area is set to extend all the way to the left right and right edges, a small amount of misalignment may result in printing beyond the edge of the media.



## Media feed is not smooth (slippage occurs)

### Is thick media being used?

If the surface of the media rubs against the printing heads and smooth feed is impossible, then adjust the height of the printing heads (see "2-2 Loading Media -- When Loading Thick Media").

When the height of the printing head has been adjusted, it is necessary to perform bidirectional correction (only when performing bidirectional printing). For more information about bidirectional correction, see "3-6 Making Corrections for Printing -- Bidirectional Correction."

### Is using sheet media, does the loaded media contact areas such as the stand's media flange?

If the sheet media contacts the media flange or the like at the back of the unit, shift the retainer to a location where the media doesn't make contact.

If the media touches an obstruction while printing is in progress, normal media feed is not performed, and image quality may suffer or the media may jam.

### Is the sheet media loaded at an angle? Are the left and right edges of the media not straight?

If the media is loaded at an angle or if the left and right sides of the media are not cut straight, the location of the edges may shift as feed is carried out. This may cause the media to rub against the inner side of this machine or be displaced from the printing area.

### Is the roll media loaded correctly?

If the roll media is not loaded correctly, the media may come loose or advance at an angle. Refer to "2-2 Loading Media -- Loading Roll Media" and load the media correctly.

## The media becomes jammed

### ■ If [MOTOR ERROR : TURN OFF POWER] appears and operation stops

Follow the steps below to clear the error.

- 1** Press the [POWER] key to switch off the sub power.
- 2** Remove the jammed media. Cut off any creased or torn portions.
- 3** Press the [POWER] key to turn on the sub power.
- 4** Correct whatever caused the media to jam.  
(For example, if thick media has been loaded, then adjust the height of the printing heads.)
- 5** Load the media and carry out setup.
- 6** Press the [CLEANING] key to perform head cleaning and a printing test (see "4-1 Cleaning the Printing Heads").
- 7** Send the printing data and perform printing.



#### **Point**

Jammed media may damage or soil the printing heads. Be sure to perform head cleaning first before sending the printing data.

## What to Do If the Printing Carriage Does Not Operate

During operation, if for some reason the printing carriage does not return to the standby position, then following the procedure, cap the printing heads, and contact your authorized Roland DG Corp. dealer or service center.

If the printing carriage is allowed to stand for a prolonged period with the printing heads uncapped (that is with the printing carriage over the platen), the heads may become clogged or even damaged.

### Capping the Printing Heads

**1** Make sure the main power is switched off, then open the cover on the right side of the machine.

**2** Open the front cover and move the printing carriage to the standby position by hand.

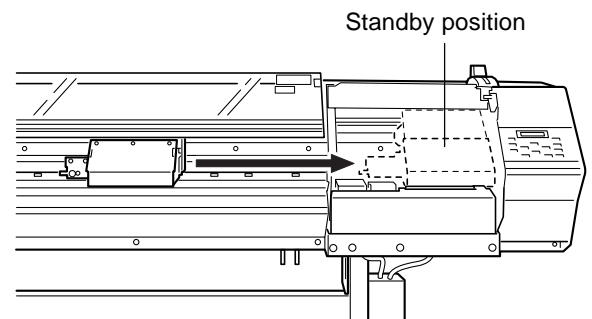

**3** Insert the oval end of the pipe included with the machine into the hole in the bottom of the machine, then rotate the pipe.

The cap unit rises.

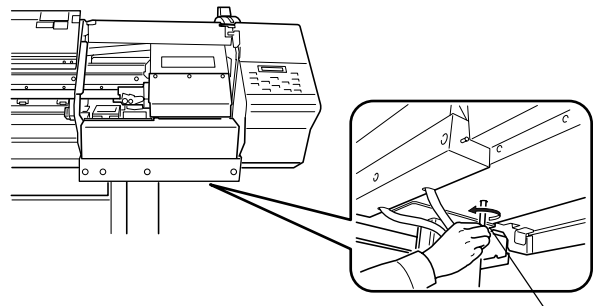

**4** Align the guides at the two ends of the cap unit with the guides at the two ends of the printing carriage.

Turn the pipe more bring the cap unit close to the printing carriage.

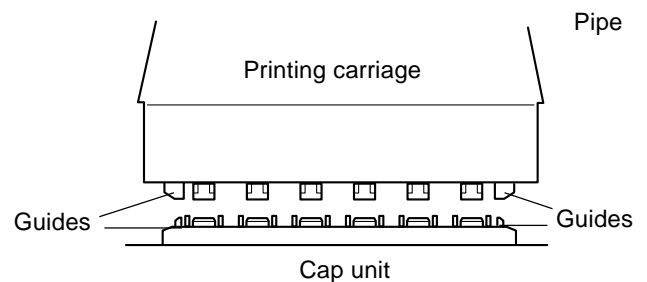

- 5** When the printing carriage comes into contact with the caps, rotate the pipe one or two turns more.

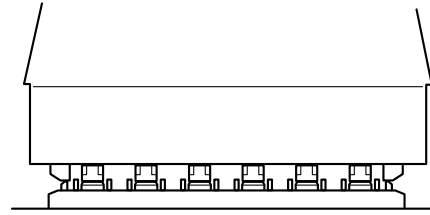

Make sure the printing carriage and the caps are touching, then contact your authorized Roland DG Corp. dealer or service center.

## 6-2 What to Do If an Error Message Appears

Messages	Meaning	Action
CLOSE THE COVER	An operation command was given while the cover or front cover is open.	Close the cover or front cover.
SHEET NOT LOADED PRESS SETUP KEY	Test printing was attempted with no media loaded.	Load the media and try again. Press the [ENTER] key to continue.
1_ 2■ 3■ 4■ 5■ 6■ 7_ 8■ 9■ 10■ 11■ 12■	Ink has been used up. * The message at left indicates that the 1 and 7 ink has been used up.	Replace the empty ink cartridge.
SET CARTRIDGE 1 2 3 4 5 6 7 8 9 10 11 12	An ink cartridge was removed. A request to insert an ink cartridge was made from this machine.	Insert the specified ink cartridge.
REMOVE CARTRIDGE 1 2 3 4 5 6 7 8 9 10 11 12	A request to remove an ink cartridge was made from this machine.	Take out the specified ink cartridge.
SET CL-LIQUID 1 2 3 4 5 6 7 8 9 10 11 12	A request to insert a cleaning cartridge was made from this machine.	Insert the specified cleaning cartridge.
REMOVE CL-LIQUID 1 2 3 4 5 6 7 8 9 10 11 12	A request to remove a cleaning cartridge was made from this machine.	Take out the specified cleaning cartridge.
EMPTY DRAIN BOTTLE	Discard discharged ink. * This message appears before operations that will discharge large amounts of ink. There is a chance of discharged ink overflowing if operations are carried out while the drain bottle is full.	Remove the drain bottle from this machine, discard the collected ink, then reinstall the drain bottle. Press the [ENTER] key to continue.
INSTALL DRAIN BOTTLE	Check that the drain bottle is set in position.	Set the drain bottle in place. Press the [ENTER] key to continue.
TO CANCEL, HOLD DOWN SETUP KEY	Operation was paused by pressing the [PAUSE] key, but there is still some remaining data.	Pressing the [PAUSE] key again to resume operation. Press the [SETUP] key to clear the data.
DRY-UP OF HEAD MAY GIVE DAMAGE	Emergency stop was effected. * "CLOSE THE COVER" is also displayed repeatedly. Audible alert each 10 sec. After 1 min., audible alert goes continuously.	Close the cover or front cover. * When restarting print, such detect like raster line or shift of band may happen.
DO NOT USE MEDIA CLAMPS	Do not use media clamps. *This message appears when position the printing head at 1 (low).	Detach media clamps to the media. Press the [ENTER] key to continue.

\* [1 2 3 4 5 6 7 8 9 10 11 12] indicate the numbers of the ink-cartridge ports. The character indicating the number of the ink-cartridge port flashes when action is necessary.

[Example]

```
SET CARTRIDGE
123456789101112
```

If "4,5,10,11" is flashing:

Install ink cartridges in ink-cartridge ports 4, 5, 10, and 11.

## 6-2 What to Do If an Error Message Appears

Messages	Meaning	Action
MOTOR ERROR TURN OFF POWER	A motor error occurred.	Recovery from this problem is impossible. Use the POWER key to switch the power off and back on again. After rectifying the cause of the error (a media jam or the like), switch on the power. Do not leave the unit with the printing carriage not in standby position.
TEMPERATURE IS TOO LOW	The air temperature where installed is lower than the ambient temperature at which the unit can operate (approx. 5°C (41°F) or more lower).	Recovery from this problem is impossible. Use the [POWER] key to switch the power off. First raise the temperature of the area where installed, then switch on the power.
SHEET SET ERROR SET AGAIN	The [SETUP] key was pressed even though no media is loaded. Setup was performed with no media at the correct location.  [Sheet Type] is set to [OPAQUE], but transparent media was loaded.  An attempt was made to load media that is too small.  The reflective tape is dirty.	Load media at the correct location and press the [SETUP] key again (see "2-2 Loading Media").  When using transparent media, set [SHEET TYPE] to [CLEAR] (see "3-5 Using Transparent Media").  Replace with media of loadable size.  Wipe off the grime on the reflective tape, then perform setup again.
PINCHROLL ERROR LOWER PINCHROLL	The [SETUP] key was pressed with the pinch rollers up. The pinch rollers were raised during setup.	Move the sheet loading lever toward "LOAD" and lower the pinch rollers, then press the [SETUP] key (see "2-2 Loading Media").
AVOIDING DRY-UP TURN OFF POWER	The printing head was returned to its standby position to be capped, canceling current printing job. Because emergency stop was effected more than 10 min.	Turn power off by pressing [POWER] key to reset. Interrupted printing is not resumed. Repeat printing from the beginning.
CANCELED FOR PROTECTING MOTOR	Continuous operation caused the pump motor to become hot, so operation was paused to prevent damage to the motor.	Press any key to cancel the message. Allow the unit to stand for about 40 minutes, then resume operation.
SERVICE CALL No: * * * *	<ul style="list-style-type: none"> <li>A problem occurred that resulted in a error that cannot be canceled.</li> <li>Correct operation became impossible because an error occurred.</li> <li>The useful life has ended for a component that must be replaced by a service technician.</li> </ul>	Check the number shown on the display, then press the [POWER] key to switch off the power. After you switch off the power, inform your authorized Roland DG Corp. dealer or service center of the number that appeared on the display.
DATA ERROR CANCELING...	A problem was found in the data received.	Make sure the cable is attached securely.
SET HEAD HEIGHT TO ***	The head height and the loaded media do not match.	Change the head height to the specified height and press the [ENTER] key.

## ***7. Appendix***

---

# 7-1 Specifications

## Main unit Specification

		FJ-540
Printing method		Piezo ink-jet method
Printing width		210 to 1361 mm (8-5/16 to 53-9/16 in.)
Acceptable media widths		210 to 1371 mm (8-5/16 to 54 in.)
Conditions for usable media		Maximum media thickness: 1.0 mm (0.039 in.) Maximum diameter for roll media: 180 mm (7-1/16 in.) Core inner diameter for roll media: 50.8 mm (2 in.) or 76.2 mm (3 in.) Maximum weight for roll media: 20 kg (44.1 lb.)
Ink cartridges	Pigmented ink	Exclusive pigmented ink cartridge
	Capacity	220 cc ±5 cc
	Colors	The six colors black, cyan, magenta, yellow, light cyan, and light magenta or the six colors black, cyan, magenta, yellow, orange, and green
	Dye-based ink	Exclusive dye-based ink cartridge
	Capacity	220 cc ±5 cc
	Colors	The six colors black, cyan, magenta, yellow, light cyan, and light magenta
Printing resolution (Printing dot resolution)		Max. 1440 dpi
Distance accuracy		Error of less than ±0.3% of distance traveled, or 0.3 mm, whichever is greater (at Roland PET-film, print travel: 1 m (39-3/8 in.))
Printing heads cleaning		Automatic cleaning and manual cleaning
Interface		Bidirectional parallel interface (compliant with IEEE 1284: Nibble mode, ECP mode (non compression) ) and Ethernet 10Base-T or 100Base-TX
Power-saving function		Auto-sleep
Power consumption	Printing mode	Maximum: 2.0A/100V to 240V ±10% 50/60 Hz
	Standby mode	Maximum: 0.6A/100V to 240V ±10% 50/60 Hz
Acoustic noise level	Printing mode	65dB (A) or less
	Standby mode	40dB (A) or less (According to ISO7779)
Dimensions	Main unit	2699 mm [W] x 742 mm [D] x 519 mm [H] (106-5/16 in. [W] x 29-1/4 in. [D] x 20-7/16 in. [H])
	With stand	2699 mm [W] x 742 mm [D] x 1300 mm [H] (106-5/16 in. [W] x 29-1/4 in. [D] x 51-3/16 in. [H])
Packed dimensions		2835 mm [W] x 850 mm [D] x 965 mm [H] (111-5/8 in. [W] x 33-1/2 in. [D] x 38 in. [H])
Weight	Main unit	130 kg (286.6 lb.)
	With stand	146 kg (321.8 lb.)
Packed weight		212 kg (467.3 lb.)
Environment	Power on	Temperature: 15 to 32°C (59 to 89.6°F), Humidity: 35 to 80% (non-condensing) (*1)
	Power off	Temperature: 5 to 40°C (41 to 104°F), Humidity: 20 to 80% (non-condensing)
Included items		power cord : 1, stay (right) :1, stay (left) :1, stand leg : 1, casters : 2, media guide : 1, bolts (large): 16, bolts (small): 14, washers : 6, hexagonal wrench : 1, pipe : 1, media flanges : 2, flange retaining pins : 2, drain bottle: 1, bottle stand : 1, transport bars : 2, Roland SelectColor™ : 1, user's manual : 1, replacement blade for separating knife : 1,Roland-PrintServer CD-ROM : 1 ,Roland PrintServer Network Settings Guide : 1, cleaning kit : 1 (cleaning sticks : 10, tweezers : 1 pair, and wiper : 2)

(\*1)Environment

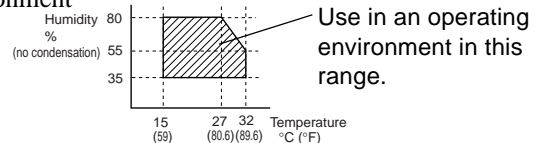



## Interface Specifications

Standard	Bidirectional parallel interface (compliant with IEEE 1284: ECP mode (non compression))
Input signals	$\overline{\text{STROBE}}$ (1BIT), DATA (8BITS), $\overline{\text{SLCT IN}}$ , $\overline{\text{AUTO FEED}}$ , $\overline{\text{INIT}}$
Output signals	BUSY (1BIT), $\overline{\text{ACK}}$ (1BIT), $\overline{\text{FAULT}}$ , SLCT, PERROR
Level of input output signals	TTL level
Transmission method	Asynchronous

## Network Interface Specifications

### 10Base-T/100 Base-TX Ethernet network cable specifications

Data	Values
Max. cable length	100 m
Cable type	S/UTP Type "category 5"
Impedance	100 Ohm
Connector type	RJ-45

## 7-2 Media Conditions

### Usable Media

Use genuine media for this machine.

- A) Maximum media thickness : 1.0 mm (0.039 in.) (When head is raised)
- B) Maximum diameter for roll media : 180 mm (7-1/16 in.) (Surface to be printed must face outward)
- C) Core inner diameter for roll media : 50.8 mm or 76.2 mm (2 in. or 3 in.)
- D) Maximum weight for roll media : 20 kg (44.1 lb.)
- E) Roll media that is not taped down to the paper tube

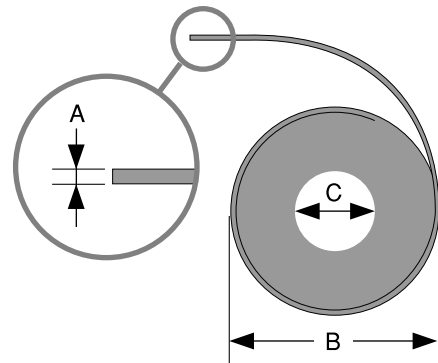

Side view of roll media

### Loadable Media Widths

210 to 1371 mm (8-5/16 to 54 in.)

## 7-3 Printing Area

The media's printable width (the direction of printing carriage movement) is determined by the width of the loaded media. When the [SETUP] key is pressed after loading the media, the width of the media is detected and the printing area appears on the display. The printing area is normally 10 mm (3/8 in.) inward from the respective left- and right-hand edges of the media.

When the printable width have been specified with the [PRINT AREA] menu, the margins are in accordance with these setting values.

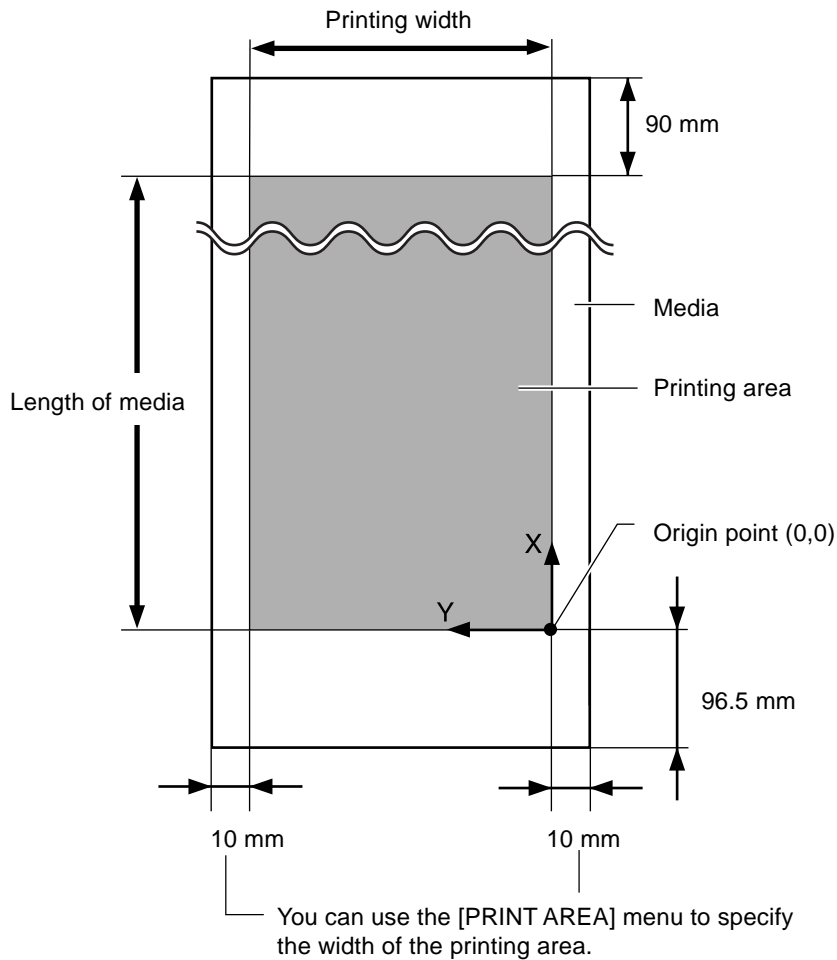

## 7-4 The Media-cutoff Location During Continuous Printing

The media-cutoff location that is used when a media-cutoff command is sent from the computer is determined as follows.

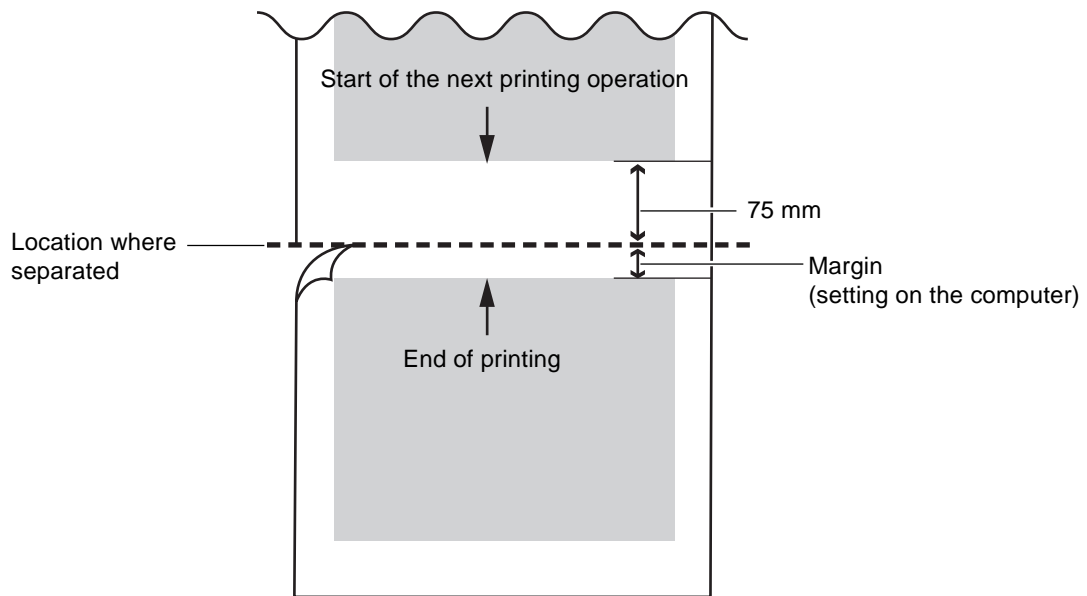





26015395-R2

R2-021011